

PARK PLACE TOWNHOMES CIVIL CONSTRUCTION PLANS

A PORTION OF SECTION 15,
TOWNSHIP 17 NORTH, RANGE 5 EAST,
GILA AND SALT RIVER, BASE AND MERIDIAN,
YAVAPAI COUNTY, ARIZONA
CONTAINING 9.73 ACRES MORE OR LESS

BASIS OF BEARING AND ELEVATIONS

ORTHOMETRIC HEIGHTS (ELEVATIONS) WERE TRANSFERRED TO THE SITE FROM CITY OF SEDONA BENCHMARK #17 USING GPS WITH NGS GEOID MODEL "GEOID99" REFERENCED TO THE PUBLISHED HEIGHT OF THIS STATION. SEDONA BENCHMARKS ARE NOMINALLY REFERENCED TO THE NGVD29 VERTICAL DATUM.

THE BASIS OF BEARINGS FOR THIS PLAT IS BETWEEN "POINT 3" AND "POINT 2".
THE BEARING IS S42°10'47"W, 1,724.75'

POINT 1
1/2" REBAR W/ PLASTIC CAP "LS14184"
N 5,472.72
E 5,818.08
ELEV: 4,492.84

POINT 2
1/2" REBAR W/ PLASTIC CAP "LS14184"
N 5,655.46
E 5,668.62
ELEV: 4,482.69

POINT 3
1/2" REBAR W/ PLASTIC CAP "LS14184"
N 6,934.43
E 6,827.68
ELEV: 4,466.94

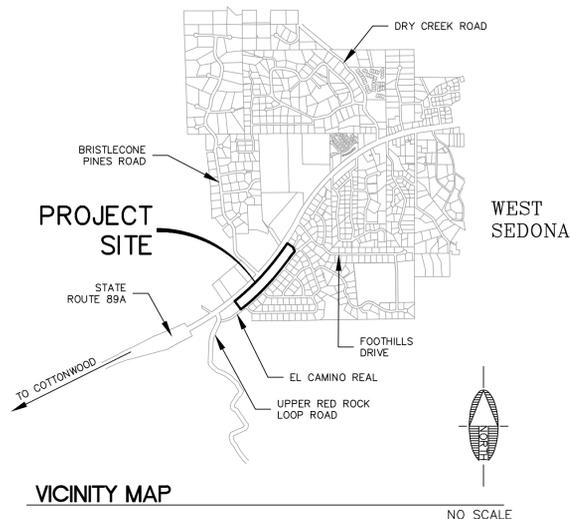

LEGEND

- CONTOUR LINES
- SUBDIVISION BOUNDARY
- BUILDING SETBACK
- BLOCK WALL
- CHAIN LINK FENCE
- STORM DRAIN PIPING
- EXISTING SEWER PIPING
- EXISTING WATER PIPING
- SEWER PIPING
- WATER PIPING
- STORM DRAIN CATCH BASIN
- SEWER MANHOLE
- SWITCH CABINET
- WATER BLOWOFF VALVE
- WATER VALVE
- WATER METER
- UNKNOWN UTILITY STUBOUT
- ASPHALT PAVEMENT
- CONCRETE
- TOP OF WALL

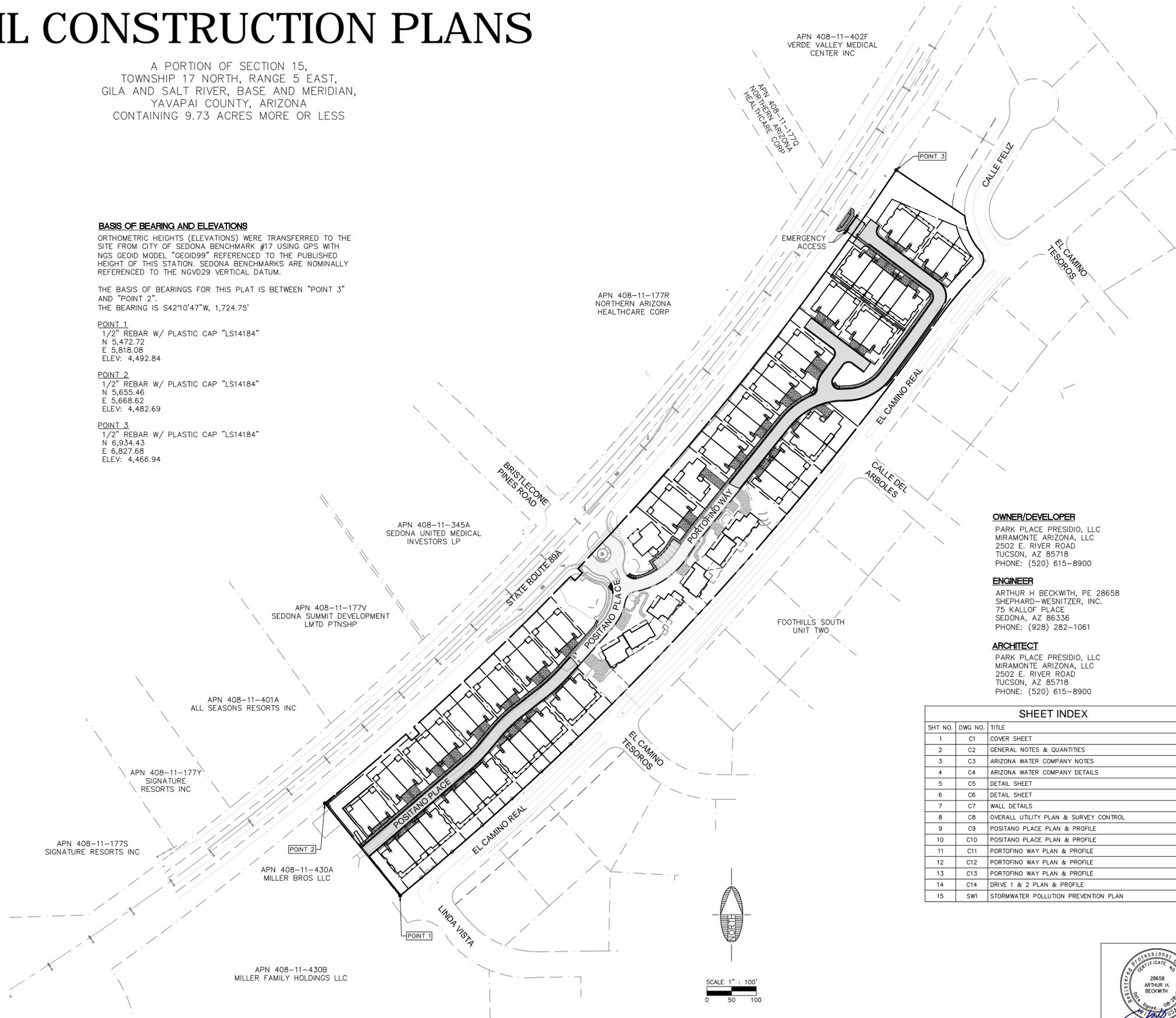

OWNER/DEVELOPER
PARK PLACE PRESIDIO, LLC
MIRAMONTE ARIZONA, LLC
2502 E. RIVER ROAD
TUCSON, AZ 85718
PHONE: (520) 615-8900

ENGINEER
ARTHUR H BECKWITH, PE 28658
SHEPARD-WESNITZER, INC.
75 KALLOF PLACE
SEDONA, AZ 86336
PHONE: (928) 282-1061

ARCHITECT
PARK PLACE PRESIDIO, LLC
MIRAMONTE ARIZONA, LLC
2502 E. RIVER ROAD
TUCSON, AZ 85718
PHONE: (520) 615-8900

SHEET INDEX

SHT NO.	DWG NO.	TITLE
1	C1	COVER SHEET
2	C2	GENERAL NOTES & QUANTITIES
3	C3	ARIZONA WATER COMPANY NOTES
4	C4	ARIZONA WATER COMPANY DETAILS
5	C5	DETAIL SHEET
6	C6	DETAIL SHEET
7	C7	WALL DETAILS
8	C8	OVERALL UTILITY PLAN & SURVEY CONTROL
9	C9	POSITANO PLACE PLAN & PROFILE
10	C10	POSITANO PLACE PLAN & PROFILE
11	C11	PORTOFINO WAY PLAN & PROFILE
12	C12	PORTOFINO WAY PLAN & PROFILE
13	C13	PORTOFINO WAY PLAN & PROFILE
14	C14	DRIVE 1 & 2 PLAN & PROFILE
15	SW1	STORMWATER POLLUTION PREVENTION PLAN

SCALE 1" = 100'
0 50 100



CITY OF SEDONA
ARIZONA

PARK PLACE

COVER SHEET

JOB NO:	17186
DATE:	AUG 19
SCALE:	AS SHOWN
DRAWN:	MWJ
DESIGN:	AHB
CHECKED:	AHB

75 Kallof Place
Sedona, AZ 86336
928.282.1061 fax
928.282.2058 fax
www.swi.coz.com

SWI
Shephard Wesnitzer, Inc.

NO.	DESCRIPTION	DATE	BY

Call at least two full working days before you begin excavation.
ARIZONA 811
Arizona Blue Stake, Inc. (928-5348)
Call 8-1-1 or 1-800-534-8111 (928-5348)

DRAWING NO.
C1

SHT NO. OF
1 OF 15

MATERIALS AND WORKMANSHIP

All materials and workmanship shall comply with City of Sedona Engineering Standards and Specifications, "Maricopa Association of Governments Uniform Standard" (MAG Specs), "Maricopa Association of Governments Uniform Standard Details for Public Works Construction" (MAG Details), "Yavapai County Association of Governments Uniform Standard and Details" (YAG Specs & Details), and generally accepted good construction practices.

The Engineer may require the submittal of a "Certificate of Compliance" and/or "Manufacturer's Guidelines" for any materials used in the work. Manufacturer's guidelines shall consist of written instructions for shipping, handling, unloading, cutting, joining, installation, storage, and/or any other facets of working.

Shop drawings shall be provided by the contractor per MAG Section 105.2.

The Engineer may order any materials used in the work to be tested according to AASHTO and ASTM Standards. The Contractor shall, at his expense, supply certificates or results of testing.

ALTERNATE MANUFACTURER AND MODEL

The contractor may submit carefully documented and considered written proposals for alternate materials and construction methods. Those proposals that are found to be in conformity with good engineering design and can be easily maintained by City forces may be given written approval for incorporation in the construction plans if they are found to be in the public interest.

UNAUTHORIZED WORK

Any work performed without the knowledge and approval of the Engineer or his authorized representative, is subject to removal and replacement at the contractor's expense.

QUALIFICATIONS OF CONTRACTOR

All improvements shall be constructed by contractors licensed by the Arizona State Registrar of Contractors, with a class of license(s) for the specific work being performed.

CONSTRUCTION OBSERVATIONS

An observation of improvements will be conducted by the Engineer and shall be provided at the developers expense, as required by the City Engineer.

Submittal of an Engineer's Certificate of Completion is required by ADEQ for all water and sewer system construction. Related observation and testing shall be provided by the developer's engineer at the developer's expense.

The Engineer shall be notified 24 hours prior to beginning different phases of construction so that observations may be scheduled.

FINAL ACCEPTANCE

Final acceptance of the construction, by the City Engineer, is required before releasing of a permit and/or transferring ownership of the improvements to the City of Sedona.

Approval of a portion of the work in progress does not guarantee its final acceptance. Testing and evaluation may continue until written final acceptance of a complete workable unit. Acceptance of completed improvements will not be given until defective or unauthorized work is removed, and final clean-up is complete.

City of Sedona reserves the right to request modifications to these plans during construction if field conditions warrant and the design engineer concurs.

WARRANTY

Any defects which appear in the work within two years from the date of acceptance and which are due to improper workmanship or inferior materials supplied shall be corrected by or at the expense of the contractor.

SUSPENSION OF WORK

The Engineer or his authorized representative may suspend the work by written notice when, in his judgment, progress is unsatisfactory, work being done is unauthorized or defective, weather conditions are unsuitable, or there is danger to the public health or safety.

MAINTENANCE OF FACILITIES AND WORK

The Contractor shall be responsible for maintenance of the streets and of partially completed portions of the work until final acceptance of the work. Contractor shall be responsible for maintaining the quality of existing streets leading to the project site. Existing streets found to be damaged by construction traffic shall be repaired to the satisfaction of the City Engineer by the Contractor at no additional expense to the Owner.

UTILITIES

Utilities must be located to minimize interference with one another, to provide required horizontal and vertical separations, and to provide maintenance access without violating easement boundaries.

BLUE STAKE

Location of underground utilities shall be accomplished in accordance with ARS 40-360.22 prior to any excavation. Blue Stake shall be called at 1-800-STAKE-IT for accurate location of utilities as necessary and prior to any excavation.

COOPERATION WITH UTILITIES

A utility coordination meeting shall be coordinated by the Contractor prior to the start of any work. All utility issues shall be addressed in accordance with MAG Section 105.6.

STREET CLOSURE

Streets closed because of construction, shall be provided with barricades and/or hazard signs as required by the Engineer and approved by the City Engineer.

AS-BUILT PLANS

Prior to approval of an improvement project, an "as-built" plan must be submitted to the City Engineer. The as-built plan shall indicate the actual location of water mains, sewer mains, underground drainage structures, all sewer and water services, all fittings, valves and manholes relative to right-of-way boundaries, lot line, or other points of survey.

The design engineer shall place all information on reproducible construction plans. The as-built reproducible plans will then be placed in City records. Appropriate submittals shall be made as required to all Agencies by the developer.

CONSTRUCTION STAKING

The accuracy of all construction work shall be maintained and verified by the developer's surveyor at the developer's expense by providing construction staking suitable to the Engineer. Stakes will be set establishing lines and grades (finish or flowline) for all construction including roads, curb and gutter, sidewalks, utilities, structures, and other work as considered necessary by the Engineer. All survey control shall be set by the developer's surveyor from monuments acceptable to the Engineer.

PERMITS AND APPROVALS

A.D.E.Q. requires permits be issued prior to new construction, extension to, or modification of a water distribution system, sewage collection or individual sewage treatment system.

City of Sedona requires the issuance of a Grading Permit for any excavation or grading (including placement of fill). A Right-of-Way permit is required prior to commencing any work within any City of Sedona Right-of-Way.

STREET CONSTRUCTION

SUBGRADE PREPARATION

Native subgrade soil to receive paving shall be stripped of vegetation, debris, organic rich soils, trees and other deleterious materials. The subgrade shall be scarified and compacted to a minimum of 95% of the maximum density as determined by AASHTO Test Method T99. Clayey soils shall be compacted and maintained (until covered) at a moisture content in the range of optimum +3 to +1%. Existing sloping areas steeper than 5:1 (horizontal to vertical) shall be benched to reduce the potential for slippage between existing slopes and new fills. Benches shall be level and wide enough to accommodate compaction and earth moving equipment. Isolated clay pockets, if any, shall be overexcavated below subgrade and replaced with granular material.

FILL CONSTRUCTION

Subbase fill shall consist of on-site or imported soils. Imported soils, if any, shall conform to the following:

Table with 3 columns: Gradation (ASTM C136), % Passing, Maximum Plasticity Index. Rows include 6" No. 4, No. 200, and 6" No. 4, No. 200.

Fill shall be placed in horizontal lifts at thicknesses consistent with compaction equipment used to achieve uniform densities throughout lift thickness. Fills less than 10 feet high shall be compacted to a minimum of 95% of the maximum density as determined by AASHTO T-99. The contractor shall contract with an independent testing laboratory to provide compaction testing. Tests shall be provided at intervals of one test per 5000 square feet of fill surface for each lift of fill construction. Test results shall be submitted to the Engineer daily.

AGGREGATE BASE COURSE

The base material shall be sand and gravel, crushed rock and/or decomposed granite with enough binder material so that it can be tightly compacted and shall have a plasticity index not in excess of 6 and shall conform to gradation as required by the City Engineer. The work and construction shall be in accordance with Section 702 of M.A.G. Standard Specifications or Section 303 of ADOT Standard Specifications, and as modified herein. Section 303-2 of ADOT Standard Specifications shall be modified as follows:

Table with 3 columns: Materials: Table 303-1 is Modified to Add, Sieve Size, % Passing. Rows include 1-1/8", 3/4", 3/8", No. 8, No. 200, and Class of aggregate - 3.

Base material shall be placed in uniform layers not to exceed 6" in depth. Each layer shall be bladed to a smooth surface conforming to the cross section shown on the plans and shall be watered and thoroughly rolled in a manner satisfactory to obtain a 95% of maximum density, based on a modified proctor.

ASPHALT CONCRETE

The work and construction requirements under this section shall be in accordance with Section 409 of ADOT Standard Specifications or Section 321 of M.A.G. Standard Specifications. Mix design shall be for 2" lift, and shall be submitted to the City Engineer for review and approval.

Asphaltic concrete shall be compacted to not less than 95.0 percent of laboratory density. The laboratory density will be determined by the Contractor's Engineer based upon field samples in accordance with the requirements of AASHTO T-245, 75 blow Marshall density.

Core samples shall be taken by the Contractor at random locations in accordance with quality control testing.

When the average percent of compaction is less than 95.0%, the Contractor may be required to remove and replace any portions, at the discretion of the City Engineer, at no cost to the City.

CHIP SEAL COAT

All new streets shall be chip sealed per the following specification:

The chip seal coat shall consist of emulsified asphalt, type CRS-2, (or equivalent) applied at a rate of 0.30 to 0.40 gallons per square yard and 3/8" inch chip cover aggregate. Emulsified asphalt shall be applied to the surface of the road in accordance with Section 404-3.05 of the ADOT Standard Specifications. Emulsified asphalt, type CRS-2 or equivalent shall conform to Section 1005-3.03 and Table 1005-5 of ADOT Standard Specifications.

Chip seal coat shall not be applied for 14 days after completion of the asphaltic concrete.

The cover material shall conform to Section 404-2.02 to the following gradation and shall be an aggregate mix of clean sand, gravel or crushed rock and shall be free of lumps or balls of clay, contain no calcareous, clay or dust coatings, caliche, synthetic materials, decomposed granite, volcanic cinders, organic matter, or foreign substances. If a clean cover

material cannot be achieved using conventional crushing and screening methods, then the cover material will have to be washed in water. The cover material shall be applied at a rate of 25 to 30 pounds per square yard.

The grading shall meet the following requirements when tested in accordance with the requirements of Arizona test method 201.

Table with 2 columns: Sieve Size, Percent by Weight Passing Sieves. Rows include 3/4", No. 4, No. 8, No. 200.

The Contractor is responsible for all laboratory test and certifications to assure that the chip material is in conformance to the requirements set forth in these specifications.

Representative samples of the aggregate cover material shall be taken daily, and the laboratory test results and certificates of compliance, certified by the Contractor's Engineer, shall be submitted to the City Engineer. The City Engineer may reject delivered chip material if, in his opinion, the delivered material differs significantly from the representative sample.

The Contractor shall be responsible for successful placement of the chip seal coat regardless of temperatures of material compliance, and shall guarantee the success of the chip seal coat. The Contractor shall comply with all ADOT Standards and Specifications 404-3.14 for dates and elevations of placement.

The Contractor shall have each individual road swept within 24 hours of the completion of the chip seal. The Contractor shall maintain traffic control and loose gravel signs until all sweeping has been completed.

Blotting shall be done wherever and whenever necessary, with a material approved by the County Engineer. All excess blotter material shall be swept away and surface of the bituminous roadway shall be reasonably clean and free of all loose material before the seal coat may be applied.

A chip seal coat is required on all asphaltic concrete projects.

RELOCATIONS

Signs, trees shrubs, mailboxes and other incidentals requiring relocation shall be moved only far enough to allow construction of the project and cause the least disruption to private property, and landscape. Final positions shall be approved by the Engineer prior to relocation. All relocated items shall continue to work in their intended capacity after the relocation has been accomplished. No signs shall be relocated to positions outside designated right-of-way. Safety shall be a primary consideration in the placement of shrubbery and signs which could possibly disrupt the sight distance of motorists.

WATER SYSTEM

All water mains, appurtenances, and installation shall conform to Arizona Water Company Standards and Specifications (See dwgs C3 & C4) and AWWA Standards and Arizona Department of Environmental Quality requirements. Water system shall be tested per A.D.E.Q. Bulletin No. 10 and AWWA Standard C-600.

All materials and products used in the drinking water system shall conform to NSF Standards 61.

Water line shall be disinfected per ADEQ bulletin No. 8. Water lines shall be buried with a minimum of 3' of cover. All hydrants shall meet all requirements of AWWA C-509-80.

All pipes and fittings shall be "LEAD FREE" per R-18-4-504.

SEWER SYSTEM

MANHOLES

All manholes shall be 4-ft. ID precast concrete with poured-in-place concrete base and traffic bearing ring and cover. All covers shall be 2'-ft. in diameter and shall be marked "Sewer". Test manholes for water tightness (infiltration) per R 18-9-E301.4.01.D.3.f.. Watertightness shall be tested by either i) Filling the manhole with water and ensuring that the drop in water level does not exceed 0.001% of the total manhole volume in one hour, or ii.) Air pressure testing using the "Standard Test Method for Concrete Sewer Manholes by Negative Air Pressure (Vacuum) Test". ASTM C-1244-93. Test 100% of all manholes. Manholes shall conform to A.D.E.Q. and M.A.G. specifications. Construction shall conform to M.A.G. Std. Dts. 420-1 and 420-2.

CONCRETE

Class A concrete shall have a minimum cement content of 564 lb. per cubic yard; a water to cement ratio of 0.58; and a minimum 28 day compressive strength of 3000 psi. Class C concrete shall have a minimum 28 day compressive strength of 2000 psi. All poured-in-place concrete for water containing and/or transporting chambers, manholes and boxes, and foundations shall be Class A concrete, and shall be smooth finished on water contact surfaces. Thrust blocks, wave anchors, and concrete surrounds may be formed from Class C concrete.

The excavation method employed shall be the Contractor's option. Material shall not be stockpiled to a depth of more than 5 feet above finished grade within 25 feet of any excavation or structure. Excavation shall extend a sufficient distance from walls and footings to allow placing and removal of forms, installation of services and inspection by the Engineer. Within 12' of finished grade shown on the drawings, and for the manholes, fill and backfill shall be native material, free from broken concrete, vegetation, or other debris with sufficient fines to fill all voids and to insure a uniformly compacted mass of the required density and having a maximum size of 3 inches with 0 to 20% minus #200. All fill and backfill shall be placed in layers of not more than 8" loose and compacted to 95% of maximum density, determined by AASHTO Test Method T-99, prior to placement of the next layer.

PIPE

Gravity sewer pipe shall be PVC, SDR-35 and conform to ASTM D-1784 and ASTM D-3034. Seals shall conform to ASTM F-477. Pipe shall be joined by bell and spigot type joints. Fittings shall conform to ASTM D-3212. Gravity sewer pipe shall be tested for deflection and leakage. Short term deflection testing shall be performed after complete backfill but prior to installation of finish surface material. A short term deflection in excess of 5% shall be considered unacceptable and pipe shall be repaired, or replaced and retested. A minimum of 100% of gravity sewer shall be deflection tested. Sewer pipe shall be tested for leakage using low pressure air testing per "Standard Test Method for Installation Acceptance of Plastic Gravity Sewer Lines Using Low Pressure Air", ASTM F 1417-92, Reapproved 1998. Test 100% of all sewerlines. Test the total length of the sewer line for uniform slope by lamp lighting, Remote camera or similar method approved by ADEQ, and record the results. Ductile iron pipe shall be AWWA C-150, Class 350 and shall be tested for leakage per AWWA standard C-600. A minimum horizontal distance of 6'-ft. shall be

maintained between water mains and gravity sewers.

A.A.C. R18-4-502 DESIGN: MINIMUM DESIGN CRITERIA

- C. Water and sewer mains shall be separated in order to protect public water systems from possible contamination. All distances are measured perpendicularly from the outside of the sewer main to the outside of the water main. Separation requirements are as follows: 1. A water main shall not be placed: a. within six feet, horizontal distance, and below two feet, vertical distance, above the top of a sewer main unless extra protection is provided. Extra protection shall consist of constructing the sewer main with mechanical joint ductile iron pipe or with slip-joint ductile iron pipe if joint restraint is provided. b. within two feet horizontally and two feet below the sewer main. 2. No water pipe shall pass through or come into contact with any part of a sewer manhole. The minimum horizontal separation between water mains and manholes shall be six feet, measured from the center of the manhole. 3. The minimum separation between force mains or pressure sewers and water mains shall be two feet vertically and six feet horizontally under all conditions. Where a sewer force main crosses above or less than six feet below a water line, the sewer main shall be encased in at least six inches of concrete or constructed using mechanical joint ductile iron pipe for ten feet on either side of the water main. 4. Individual sewer service laterals will require protection.

THRUST BLOCKING

Thrust blocking is required at changes of direction and shall conform to M.A.G. Std. Dtl. 380.

TRENCHING AND BACKFILLING

Trench bottom shall be compacted by suitable means approved by the Engineer prior to placement of bedding material. Bedding material shall be placed to provide uniform and adequate longitudinal support under the pipe. The Contractor shall ensure that a minimum compacted depth of 4" is maintained underneath the pipe. Bell holes should be provided at each joint to permit proper assembly while maintaining uniform support.

Bedding material shall be rounded gravel with a maximum particle size of 3/4" and shall be non-plastic. Where depth of cover is 2'-ft. or less, backfill material shall be rounded gravel with a maximum particle size of 3/4" and with no more than 20% passing the #200 sieve.

Backfill shall be placed in layers of not more than 8" loose depth and compacted to achieve compaction of 95% of the maximum density as determined by AASHTO T-99 and T-191 or ASTM D-2922 and D-3017. The Contractor shall contract with an independent testing laboratory to provide compaction testing. Tests shall be provided at intervals of one test per 50 cubic yards of trench backfill. Test results shall be submitted to the Engineer daily.

VERTICAL SEPARATION TO DRAINAGE PIPES

Where culverts or drainage pipes cross gravity sewers, pressure sewers, or water mains, a minimum of one foot of vertical separation shall be maintained between the two pipes.

CORRUGATED METAL PIPE

Galvanized helically corrugated metal pipe and end sections shall be the size as shown on the plans with a minimum cover of 12" below top of subgrade. The pipe and end sections shall be 14 gage minimum.

Lengths and invert elevations of pipes shown on the plans are for estimating and design purposes only. Actual lengths and inverts shall be determined in the field based on the results of grade staking. All cnp's shall be installed in accordance with M.A.G. specification section 601 and 621.

All cnp's shall have end sections or concrete headwalls as shown on plans at inlet and outlet. If rock is encountered during installation of cnp, riprap may be omitted if approved by the engineer, however riprap shall not be omitted for the 2' area around the end sections.

ELECTRICAL (APS)

Electrical (APS) is shown on plans for main trench location. All transformer location and service locations to be installed per APS provided plans.

EROSION CONTROL

Temporary erosion control measures indicated on the SWPPP shall be instituted during construction. Provide silt fence at the toes of fill slopes. Provide rock check dams in diversion channels until permanent channel surfacing is installed.

ALL DISTURBED SLOPES SHALL BE MULCHED AND SEEDED PER THE FOLLOWING SEED SPECIFICATIONS:

Table with 3 columns: Species, Pure Live Seed Rate/Acre. Rows include Sand Dripsseed (Sporobolus Cryptandrus), Sideoats Grama (Boutelous Curtipendula), Crested Wheatgrass (Agropyron Cristatum).

- 1. Seeding operations shall not be performed when wind would prevent uniform application of materials or would carry seeding materials into areas not designated to be seeded. 2. The equipment and methods used to distribute seeding materials shall be such as to provide an even and uniform application of seed, mulch and/or other materials at the specified rates. 3. Seeding operations shall not be performed on undisturbed soil outside the clearing and grubbing limits of the project or on steep rock cuts. 4. Immediately before seeding, the surface area shall be raked or otherwise loosened to obtain a smooth friable surface free of earth clods, humps and depressions. Loose stones having a dimension greater than one inch and debris brought to the surface during cultivation shall be removed and disposed of by the contractor in a manner approved by the Engineer. 5. The area to be seeded shall be roughened with grooves parallel to the contours prior to seeding. A bulldozer or crawler tractor shall be driven up and down the slope parallel to the fall line to create a trackwalked slope. The seeds shall be uniformly applied in a direction parallel to the contours of the slope. 6. Immediately after seeding, the area shall be uniformly covered with screened manure at the rate of one cubic yard per 1,000 square feet and then watered until the ground is wet to a minimum depth of two inches. 7. Water shall be free of oil, acid, salts or other substances which are harmful to plants. The source shall be as approved

- 8. The contractor shall protect seeded areas from damage by traffic or construction equipment. Surfaces which are eroded or otherwise damaged following seeding and prior to final acceptance shall be repaired by regrading, reseeding and mulching as directed by the Engineer.

Table with 3 columns: Item, Description, Quantity. Sections include DEMOLITION, CONSTRUCTION, and LOT COVERAGE CALCULATION TABLE.

Table with 3 columns: Species, Pure Live Seed Rate/Acre. Rows include Sand Dripsseed (Sporobolus Cryptandrus), Sideoats Grama (Boutelous Curtipendula), Crested Wheatgrass (Agropyron Cristatum).

- NOTES TO CONTRACTOR: 1. SEE ARCHITECTURAL PLANS FOR RETAINING WALLS. 2. EXISTING WATER LINE IS DUCTILE IRON PIPE.

Site Cut/Fill Volumes

- 1. The Engineer has used his best judgment in the estimation of the earthwork for this Project. The Engineer has no control over varying field conditions and construction methods involved in the site grading. Consequently, actual quantities, cost and time required for this Project may be affected by many factors beyond the Engineer's control, and Engineer shall not be held liable for any deviation from its estimated quantities. It is the responsibility of the Contractor to verify the earthwork quantities. The following is the Engineer's estimate of raw earthwork quantities for this Project. (No shrinkage values are taken into consideration in these quantities).

Raw Cut = 22,825 C.Y. Raw Fill = 9,594 C.Y.

Professional Engineer seal for Arthur H. Beckwith, No. 28658, State of Arizona, dated 08/08/19.

Project information including City of Sedona, Arizona, Job No. 17186, Date: Aug 19, Scale: AS SHOWN, Drawing: MWJ, Design: AHB, Checked: AHB, and drawing title 'GENERAL NOTES & QUANTITIES'.

CONSTRUCTION SPECIFICATIONS FOR THE INSTALLATION OF WATER DISTRIBUTION SYSTEMS DUCTILE IRON

1. GENERAL

All work is to be completed in a safe, workmanlike manner and in accordance with these Construction Specifications; any deviation therefrom must be approved in writing by the Company.

Installations must conform with the requirements of all governmental regulating agencies and the cost of conforming to such regulations must be included in the unit bid prices. Examples of such regulations, without attempting to be inclusive, are:

- a. Special compaction and paving for street crossing.
b. Shoring when required because of the trench depth.
c. Closing a trench in those areas where no open trench is allowed overnight.
d. Barricading and traffic control as required.

2. LOCATION MARKING

Alignment stakes as required in the opinion of the Company shall be furnished by the Company to the Contractor and shall be set by the Company at agreed upon intervals and offsets. Under normal circumstances these will reference the pipeline location five feet (5') into the right-of-way measured from property pins. Grade stakes will be provided only when the Construction Drawings show a pipeline depth other than covered in these Specifications. It is the responsibility of the Contractor to preserve all survey work.

3. TRENCH EXCAVATION

The trench location is to be determined by the Construction Drawings.

FOR 8-INCH OR SMALLER PIPE: The depth of the trench prior to pipe laying shall be such that the finished pipeline shall have between thirty-six inches (36") and forty-two inches (42") of cover unless otherwise specified on the Construction Drawings.

FOR 12-INCH AND LARGER PIPE: The depth of the trench prior to pipe laying shall be such that the finished pipeline shall have between forty-eight inches (48") and sixty inches (60") of cover unless otherwise specified on the Construction Drawings.

The width of the trench at and below the level at the top of the pipe shall be a minimum of twelve inches (12") plus the outside diameter of the pipe barrel and a maximum of twenty-four inches (24") plus the outside diameter of the pipe barrel.

The bottom of the trench shall be accurately graded to provide a uniform bearing for each length of pipe for the full length of the pipe. If the native material on the trench bottom can be reasonably dug by hand, bell holes shall be dug for the joints so that the joints in no way support the pipe. When native materials such as rock are encountered during trenching that will not provide a uniform support for the pipe, the trench will be over-excavated an additional six inches (6") and suitable bedding material will be placed in the trench.

Bedding material will be placed by hand in four-inch (4") lifts and compacted to ensure uniform compaction and to eliminate any voids under the pipe. When the space between the pipe and trench bottom varies, this must be backfilled and compacted in four-inch (4") lifts to the mid-section of the pipe.

Whenever the trench is over-excavated for whatever reason, the trench bottom will be brought up to the correct depth at the Contractor's expense using either method (a) or (b) as follows:

- a. A.B.C. material shall be used and compacted to a uniform density of not less than 80% of the maximum density as determined by AASHTO T-99 method A and T-191.
b. Native material 100% of which will pass through a one and one-half inch (1 1/2") screen and at least 20% of which will pass through a number-8 screen shall be used and compacted to a uniform density of not less than 85% of the maximum density as determined by AASHTO T-99 method A and T-191.

4. MATERIALS TO BE PROVIDED BY CONTRACTOR

Unless otherwise specified on the Construction Drawings or in the Contract, the Contractor will supply all of the necessary materials which will become a permanent and integral part of the water distribution system, including concrete blocking, anchors, backfill material, paving material and supplies used during the prosecution of the work. All materials provided by the Contractor to construct the water distribution system must be NSF Standard 61 approved. All potable water pipes and fittings shall have NSF-PW seal. Construction materials used in the water system shall be lead free as defined at AAC R18-5-504 and R18-1-101. The Contractor will provide the following materials:

- a. FIRE HYDRANTS: Mueller Super Centurion 250 Fire Hydrant, meets ANSI/AWWA C502 Standard, Model No. A-423, 5/4" main valve opening, three way, 6" Mechanical Joint Shoe, 1 1/2" pentagon operating nut, color - yellow, drain open, open direction - left, 4' or 4'6" bury depending on application. For pumper and hose nozzle information see below.
(1) 1 - 4" Pumper Nozzle, NST and 2 - 2 1/2" Hose Nozzles, NST. (These locations only: Ajo, Casa Grande, Coolidge and San Manuel.)
(2) 1 - 4 1/2" Pumper Nozzle, NST and 2 - 2 1/2" Hose Nozzles, NST. (These locations only: Apache Junction, Arizona City, Lakeside, Oracle, Overgaard, Pinewood, Rimrock, Sedona, Sierra Vista, White Tank and Winkelman.)
(3) 1 - 4 1/2" Pumper Nozzle, NST and 2 - 2 1/2" Hose Nozzles, NPT (Bisbee only.)
(4) 1 - 3" Pumper Nozzle GA 6-350 (6 threads per inch, 3.50 pitch diameter) and 2 - 2 1/2" Hose Nozzles, NPT (Miami only.)
(5) 1 - 3 1/2" Pumper Nozzle GA 6-411 (6 threads per inch, 4.11 pitch diameter) and 2 - 2 1/2" Hose Nozzle, NST (Superior only.)
b. FITTINGS: Manufactured by Tyler or Union. Crosses, Elbows, Tees, Cap, Reducer, Adapter, Plug, Blind Flange and Tapped Flange; Ductile Iron, Class 350, SSB, Cast Iron Cement Lined.
(1) Foster Adaptors for MJ, made by Infact Corporation: Available in size 4" to 16". Part No. 4" = 4FA-BC, 6" = 6FA-BC, 8" = 8FA-BC, 10" = 10FA-BC, 12" = 12FA-BC, 16" = 16FA-BC.
c. DETECTOR CHECK VALVE: Mueller/ Hersey EDC III, iron body, including 5/8" x 3/4" Trim Kit. Trim Kit Part No.: 4" = 282080, 6" = 282082, 8" = 282085, 10" = 282496.

- d. GATE VALVES: Mueller Resilient Wedge Gate Valves, meets AWWA C509 specification, 250 psig, Non-rising stem, Part No. A-2360 sizes 4" through 12" ; Part No. A-2361 sizes 14" through 36", low zinc stems, epoxy coated inside and outside to meet the NSF 61 rating. The bonnet and stuffing box shall have 304 stainless steel bolts/nuts.
e. TRACER WIRE AND WARNING TAPE:
1. TRACER WIRE: Shall be direct bury AWG #14 solid copper wire, Color: Blue.
2. WARNING TAPE: Reef Industries, Standard Terra Tape in 3" widths. Color: Blue and imprinted 'Arizona Water Company'.

- f. AIR RELEASE VALVE: Crispin Model AR10 with 1" NPT inlet and 1/2" NPT outlet, cast iron body and top flange; with a 5/64" orifice with stainless steel valve sealing faces and BUNA-N rubber.
g. PRESSURE RELIEF VALVE: Watts 174A, Model M, 2" inlet, 2" outlet, Bronze Body, 30lb. to 150lb. pressure range.
h. MEGA LUG: Mechanical Joint restraint made of ductile iron conforming to ASTM 536-80, 250 psi made by EBAA Iron, Inc., series 1100 or equal.

- i. METER BOXES:
(1) Concrete Box with a steel regular lid, Number 1: Tucson specification.
(2) Concrete Box with a steel regular lid, Number 2, 3, and 4: Phoenix specification.
j. PIPE, COPPER: Type K soft copper in 60 or 100-foot coils, per ASTM B88.

- k. PIPE, DUCTILE IRON: Ductile Iron Pipe, Cement Lined, Push-on, conform to current ANSI/AWWA Specification A21.51/C151, Pressure Class 350 (sizes 4" through 12"), Pressure Class 250 (sizes 14" through 20"), or Pressure Class 200 for 24" through 36" pipe. Vendors:
(1) Pacific States Cast Iron Pipe Company
(2) Griffin Pipe
(3) United States Pipe and Foundry Company
(4) American Ductile Iron Pipe
(5) Clow Pipe (McWane, Inc.)

- l. PIPE, PLASTIC: Plastic pipe, C-900 PVC per ANSI/AWWA C900, Class 150, sizes 6" through 12". NSF61 approved. Furnished in laying lengths of 20'. The barrel shall conform to the outside dimensions of steel pipe (IPS) or cast iron (CI) pipe equivalent and the wall thickness of dimension-ratio (DR) 18.

- m. POLYETHYLENE ENCASUREMENT (Polywrap): For all pipeline and related fittings installed, EXCEPT for the Coolidge Division. Minimum 8 Mil. and installed per AWWA C105/A21.5-93 and ASTM A-674-89. Manufactured by the Pacific States Cast Iron Pipe Company. The wrapping tape shall be minimum 10 mil. vinyl tape. No duct tape shall be used.

- n. COUPLING: Mueller, straight three part union, tested to meet ANSI/AWWA C800, H15403, conductive compression.

- o. STOP, ANGLE METER, BALL: Mueller, valve, B24258, conductive compression by meter swivel nut, tested to meet ANSI/AWWA C800, size 5/8" x 3/4" x 3/4" for a 3/4" service or size 1" for a 1" service.

- o. STOP, ANGLE METER, BALL: Mueller, valve, B24258, conductive compression by meter swivel nut, tested to meet ANSI/AWWA C800, size 5/8" x 3/4" x 3/4" for a 3/4" service or size 1" for a 1" service.

- o. STOP, ANGLE METER, BALL: Mueller, valve, B24258, conductive compression by meter swivel nut, tested to meet ANSI/AWWA C800, size 5/8" x 3/4" x 3/4" for a 3/4" service or size 1" for a 1" service.

- o. STOP, ANGLE METER, BALL: Mueller, valve, B24258, conductive compression by meter swivel nut, tested to meet ANSI/AWWA C800, size 5/8" x 3/4" x 3/4" for a 3/4" service or size 1" for a 1" service.

- o. STOP, ANGLE METER, BALL: Mueller, valve, B24258, conductive compression by meter swivel nut, tested to meet ANSI/AWWA C800, size 5/8" x 3/4" x 3/4" for a 3/4" service or size 1" for a 1" service.

- p. STOP, CORP: Mueller, ball valve, B25008, taper thread by conductive compression, tested to meet ANSI/AWWA C800 specification, sizes: 3/4", 1" and 2".

- o. STOP, CORP: Mueller, ball valve, B25008, taper thread by conductive compression, tested to meet ANSI/AWWA C800 specification, sizes: 3/4", 1" and 2".

- o. STOP, CORP: Mueller, ball valve, B25008, taper thread by conductive compression, tested to meet ANSI/AWWA C800 specification, sizes: 3/4", 1" and 2".

- q. STOP, CURB: Oriseal valve, H10291, iron pipe thread by iron pipe thread, quarter turn check, brass, tested to 300 psi working pressure, tested to meet ANSI/AWWA C800 specification, size: 2".

- q. STOP, CURB: Oriseal valve, H10291, iron pipe thread by iron pipe thread, quarter turn check, brass, tested to 300 psi working pressure, tested to meet ANSI/AWWA C800 specification, size: 2". (Blow-off E-9-8-1).

- r. TAPPING SADDLE: Smith Blair, Cast Bronze ASTM-B584 85-5-5-5, double strap, iron pipe threads, Models 321 and 323. Washers are silicon bronze, ASTM-B36. Gaskets are grade 60 Buna N, or Mueller bronze double strap service saddle, BR 2 B series, cast bronze, ASTM-B585, 85-5-5-5, or H16084, 200 psig, meets ANSI/AWWA C800.

- s. TAPPING SLEEVE: Mueller H304 Stainless Steel Tapping Sleeve, JCM 432 18-8 Type 304 Stainless Steel Tapping Sleeve, Romac "SST" Type 304 Stainless Steel Tapping Sleeve or CASCADE-style CST-EX stainless steel pressure-rated tapping sleeve.

- t. TAPPING VALVE: Mueller Resilient Wedge tapping valve, Catalog Number T-2360-16, Class 125, sizes 4" through 12"; T-2361-16, Class 125, sizes 14" to 36" all with Type 304 stainless steel fasteners; bypass valves are required on 18" - 36" valve flange by mechanical joint per ANSI/AWWA C111, iron wedge, non-rising stem. Epoxy coated interior/exterior per ANSI/AWWA C550 for NSF 61 compliance. 250 PSI range for valves 4" to 12". 150 PSI range for valves 14" to 36".

- u. U-BRANCH: Mueller, H15364, 1" male iron pipe by 3/4" male iron pipe, tested to meet ANSI/AWWA C800 specification. Size: 1" x 3/4" x 13/4", straight line.

- v. VALVE BOXES: Valve Box with Cover, adjustable, Tyler 562-A or equal, made of cast iron.

- w. VAULTS: Utility Vault Company, Chandler, AZ.

- (1) 4484-WA concrete vault with a 3660 aluminum double torsion door with a recessed padlock hasp, two - 18" x 24" center knockouts.

- (2) 575-WA concrete vault with a 4874 aluminum double torsion door with a recessed padlock hasp, two - 18" x 24" center knock outs and adjustable frame.

- (3) 612-5X-WA concrete vault with a 4874 aluminum double torsion door with a recessed padlock hasp, two - 18" x 24" center knockouts.

- x. VALVE, METER: Mueller, B24265-1, Mueller 300 ball angle meter valve, female iron pipe by meter nut, quarter turn check, lock wing, tested to meet ANSI/AWWA C800 specification. Size: 1".

- o. VALVE, METER: Mueller, B24265-1, Mueller 300 ball angle meter valve, female iron pipe, quarter turn check, lock wing, tested to meet ANSI/AWWA C800 specification. Size: 1".

- y. YOKES, METER: Relocator type copper meter yoke with horizontal inlet and outlet and meter thread ends, B24118, with lock wing Mueller 300 angle ball valve, full port, sizes: 1" x 12", 5/8" x 3/4" x 7", 5/8 x 3/4" x 9".

- o. YOKES, METER: Relocator type copper meter yoke with horizontal inlet and outlet and female iron pipe threads, B2423-99000, with lock wing Mueller 300 ball angle meter valves on inlet and outlet risers. Raised 1" by-pass with lock wing Mueller 300 ball valve.

The Contractor also will be required to provide the following materials, the cost of which will be included in its unit bid price:

All material and concrete for thrust blocks, other anchors, reinforcing steel, all gravel, crushed stone, A.B.C., earth, sand, or screened material which may be required; all material for bracing and shoring trenches and for construction of forms; all barricades and traffic control equipment; all material for paving replacement and any water used for compaction of backfill.

5. INSTALLATION OF MATERIALS

All materials are to be installed in accordance with manufacturers recommendations unless otherwise directed by these Specifications.

All pipe, fittings and valves shall be laid true to the lines, grades and locations established by the Specifications and the Construction Drawings.

The ends and inside of the pipe shall be thoroughly cleaned and inspected for damage. No damaged materials shall be installed in the water distribution system.

Whenever the work ceases for any reason, all open pipeline ends shall be tightly plugged by the Contractor. Plugs shall be watertight and approved by the company.

Concrete thrust blocks of the sizes required by the plans and specifications are to be provided at all valves, changes in direction or size, or at any other point where an unbalanced thrust due to water pressure would exist. Thrust blocks are to be formed to prevent any concrete from spilling over or into a joint.

Trench curves as shown on the Construction Drawings may be made without fittings when using push on joint pipe up to twelve inches (12") in diameter, if the deflection of (18") length of pipe. The minimum radius of such curves will be two hundred five feet (205').

Prior to construction, the appropriate agency(ies) will be notified as required by the permit(s).

It shall be the Contractor's responsibility to uncover all existing water lines being connected to, and to verify the location, depth and size of pipe before any construction begins.

Any construction performed without the knowledge of the duly authorized representative is liable for removal and replacement at the Contractor's expense.

All fire hydrants, frames, covers and valve boxes, etc. shall be adjusted to finished grade prior to the placing of the asphalt concrete surface course by the Contractor (where applicable).

Air release valves shall be installed at water system high points per Standard Detail E-9-8-2.

All water services shall be set a minimum of two feet (2') on the customer's property, preferably within the P.U.E. and not within right-of-way.

Unless otherwise specified on the construction drawings, all water mains shall be installed five feet (5') from the property line inside the right-of-way or easement.

Water valves shall be spaced not more than five hundred feet (500') in commercial districts and not more than eight hundred feet (800') in other districts. Variations may be required for transmission mains or special applications.

Installation of water line casing shall be per Standard Specification E-9-24-1.

Tracer Wire and Warning Tape are to be installed on all mains, tees, crosses, ells and fire hydrant laterals. They will not be installed on service lines. The tracer wire will be installed on the water main 45 degrees from the vertical centerline of the pipe and shall be taped to the fittings directly and on the main every 10 feet using a minimum 10 mil vinyl tape. The tracer wire shall be placed between the valve riser and box with a minimum of 12" of wire inside. The warning tape shall be installed a minimum of two feet below the surface, being measured from final grade, directly over the center of the pipe. Any splices in the tracer wire shall be joined using waterproof connectors. Any splices in the warning tape shall be joined using minimum 10 mil vinyl tape. The tracer wire shall be tested for continuity after backfill and compaction, but before paving. Any detected damages to the wire shall be repaired before paving will be allowed.

6. BACKFILL OF WATER MAIN TRENCHES

Backfill of any excavation shall conform to the requirements of any of the governmental agencies having jurisdiction over the location. If no governmental agency having such jurisdiction specifies backfill or compaction requirements, and no special requirements are shown on the Construction Drawings, the procedure set forth in this section will apply for water line trenches.

The bedding material above the pipe and backfill material shall be compacted to a minimum of 70% compaction within a utility easement and 80% compaction within a

right-of-way as determined by AASHTO T-99 method A and T-191. If water settling is used for compaction, it is the responsibility of the Contractor to prevent the pipe from floating.

The bedding material shall be either native material, 100% of which will pass through a one and one-half inch (1 1/2") screen and at least 20% of which will pass through a number-8 screen, or imported material which conforms to M.A.G. specifications for A.B.C. or type-B select materials. Bedding material shall be used below and around the pipe and a minimum of twelve inches (12") above the pipe. Shade and bedding material to be mechanically compacted prior to remainder of trench back-fill.

The remainder of the trench shall be backfilled with native or imported material which shall be of sound earthen material free from broken concrete, wood, broken pavement, or other unsuitable substances. Except as otherwise specified, backfill may be material containing no pieces larger than six inches (6") in greatest dimension.

Where settlement occurs, additional backfill material shall be placed and compacted and the trench shall be brought to final grade.

7. HYDROSTATIC TESTING OF COMPLETED PIPELINES

Hydrostatic testing of water pipelines will be completed before the new system is connected into the existing water system so that all testing can be done against all new materials.

The completed section of water pipeline to be tested shall be slowly filled with water with care being taken to expel all air from the pipe. If necessary, the pipe will be tapped at high points to vent air.

The Contractor shall provide all equipment and labor necessary to accomplish this testing and the price shall be included in the unit prices. The Contractor shall notify the Company in advance of the testing so that the Company can schedule a duly authorized representative to be at the site during testing. The Contractor, at its own expense, shall make any necessary repairs to the system being tested in order to cause the section being tested to meet the test limits set below. The Contractor may request authorization of the Company to connect the new pipelines to the existing system prior to completion of pressure testing when, in the Company's sole opinion and judgment, conditions warrant such connection.

The Contractor shall assume all responsibility to complete pressure testing to Company's specifications after such connection, including, but not limited to, isolation of the new pipelines from the existing system, if necessary.

Connections prior to completion of pressure testing shall not be made unless prior Company authorization has been obtained, and any extra expenses resulting from such connections shall be the sole responsibility of the Contractor.

Leakage tests will be for a period of two hours at 200± 5 psi at the point of lowest elevation; leakage may not exceed 0.1 gallons per hour per one thousand feet (1,000') of pipe per inch of diameter. If dry utilities are not installed, a second pressure test is required.

8. STERILIZATION AND FLUSHING OF COMPLETED WATER PIPELINES

Sterilization and flushing will conform to recommendations of Arizona State Department of Health Services Engineering Bulletin Number 8, latest edition, or any future Arizona Department of Environmental Quality bulletins. Contractor to follow all conditions of any discharge permit.

9. NO OTHER UTILITIES ALLOWED IN OR NEAR WATER PIPELINE TRENCHES

No other utility installations will be permitted in the water pipeline trench or within five feet (5') of the Company's water pipeline when running parallel to the water pipelines.

10. PROTECTION OF WATER MAINS NEAR SEWERS

In order to protect water mains from contamination by sewers, the installation of the water mains must conform to the following requirements:

- a. Horizontal - When water lines and sewers are laid parallel with each other, the horizontal distance between them shall not be less than six feet (6'). Each line shall be laid on undisturbed or bedded material in a separate trench. Where conditions prevent the minimum horizontal separation set forth above, extra protection will be required. Extra protection shall consist of constructing the sewer main with mechanical joint ductile iron pipe or with slip-joint ductile iron pipe if joint restraint is provided, or encasing both the water main and sewer main in concrete. See Detail E-9-30-1 and E-9-30-2.

The Construction Drawings shall indicate the installation requirements. The drawings showing these exceptions shall have been approved by the appropriate state and/or county health department. Refer to the diagram below for clarification.

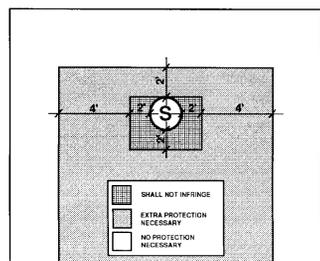

Under no circumstances will the horizontal separation between sewer mains and water mains be less than two feet (2'). All distances are to be measured from the outside of the sewer main to the outside of the water main.

- b. Vertical - When a water main is parallel with or crosses a sewer main within two feet (2') above the sewer or greater than two feet (2') below the sewer, extra protection will be required. Extra protection shall consist of constructing the sewer main with mechanical joint ductile iron pipe or with slip-joint ductile iron pipe if joint restraint is provided, or encasing both the water main and sewer main in concrete. See Detail E-9-30-1 and E-9-30-2.

The Construction Drawings shall indicate the installation requirements. The drawings showing these exceptions shall have been approved by the appropriate state and/or county health department.

Under no circumstances will the vertical separation of a sewer main installed above a water main be less than two feet (2'). All distances are to be measured from the outside of the sewer main to the outside of the water main. Refer to the diagram above for clarification.

- c. When unusual conditions such as, but not limited to, highway or bridge crossings prevent the water and sewer main separations required from being met, the appropriate state and/or county health department will review and may approve requests for authorization to use alternate construction techniques, materials and joints on a case-by-case basis.

- d. No water pipe shall pass through or come into contact with any part of a sewer manhole. The minimum horizontal separation between water mains and manholes shall be six feet (6'), measured from the center of the manhole.

- e. The minimum separation between force mains or pressure sewers and water mains shall be two feet (2') vertically and six feet (6') horizontally under all conditions. Where a sewer force main crosses above, or less than six feet (6') below, a water line, the sewer main shall be encased in at least six inches (6") of concrete for ten feet (10') on either side of the water main. Refer to the diagram below for clarification.

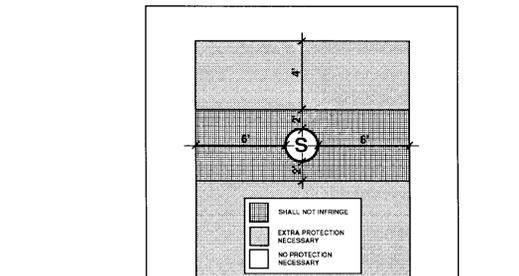

- f. Sewer mains (gravity, pressure, force) shall be kept a minimum of fifty feet (50') from drinking water wells, unless the following conditions are met:

- 1. Water main pipe, pressure tested in place to 50 psi without excessive leakage, may be used for gravity sewers at distances greater than twenty feet (20') from drinking water wells.
2. Water main pipe, pressure tested in place to 150 psi without excessive leakage, may be used for pressure sewers and force mains at distances greater than twenty feet (20') from drinking water wells.

- g. No septic tank/disposal field system shall be constructed within one hundred feet (100') of a drinking water well.

- h. All distances are measured perpendicularly from the outside of the sewer main to the outside of the water main. These separation requirements do not apply to building, plumbing or individual house service connections.

- i. Use Mechanical Joint ductile iron pipe with Megalug thrust restrains a minimum of ten (10) feet on each side of a sewer or storm drain crossing.

11. COMPACTION

When crossing existing water mains a minimum of 95% compaction is required to the bottom of existing mains.

Arizona Water Company requires that no slurry be permitted to contact existing cement/asbestos or ductile iron pipes, unless authorized by the company. Slurry may be poured in the bottom of the sewer trench stopping three inches (3") below the existing water main. The backfill used around the main should be AB in sufficient depth to prevent slurry from contacting existing main.

12. WATER MAIN MATERIAL SPECIFICATIONS

Ductile iron pipe (Push-on type) minimum class 350, cement lined and conform to AWWA C151.

All main line valves shall conform to AWWA C500 with a minimum working pressure of 200 psi.

All cast iron fittings to be cement lined in accordance with AWWA C104 and shall conform to AWWA C110 with a minimum working pressure of 250 psi. Except for the Coolidge System - See Note 4L.

Maximum joint deflection for 6" mechanical joint ductile iron pipe is seven degrees, seven minutes (7° 7') or twenty-seven inches (27") per eighteen-foot (18') length pipe, for a maximum curve of one hundred forty-five feet (145'). Maximum joint deflection for 8" and 12" mechanical joint ductile iron pipe is five degrees, twenty-one minutes (5° 21') or twenty inches (20") per eighteen-foot (18') length pipe, for a maximum curve of one hundred ninety-five feet (195').

Maximum joint deflection for 6", 8" and 12" push-on joint ductile iron pipe is five degrees (5°) or nineteen inches (19") per eighteen-foot (18') length pipe for a maximum curve of two hundred five feet (205').

NOTES SHOWN ON THIS SHEET HAVE BEEN PREPARED BY ARIZONA WATER COMPANY AND ARE FOR REFERENCE ONLY. IT IS THE CONTRACTOR'S RESPONSIBILITY TO VERIFY THE DETAILS ARE THE LATEST EDITION. SWI IS NOT RESPONSIBLE FOR DETAIL ACCURACY.



Project information including: CITY OF SEDONA ARIZONA, PARK PLACE, JOB NO. 17186, DATE: AUG 19, SCALE: AS SHOWN, DRAWN: N/A, DESIGN: N/A, CHECKED: N/A, 75 Killost Place Sedona, AZ 86336, 928.282.2056 fax, www.swi.az.com, SWI logo, Shephard Westnizer, Inc. logo, DRAWING NO. C3, SHT NO. 3 OF 15.

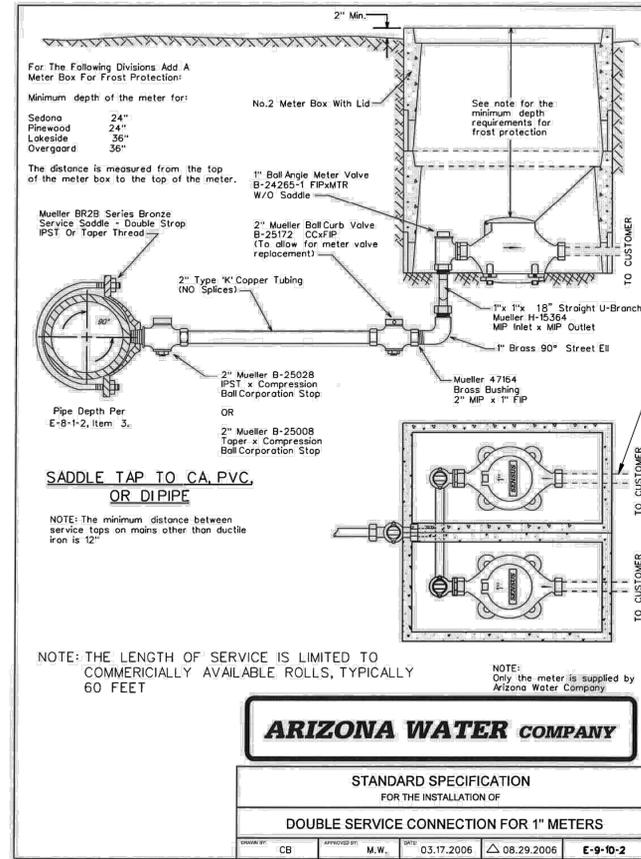
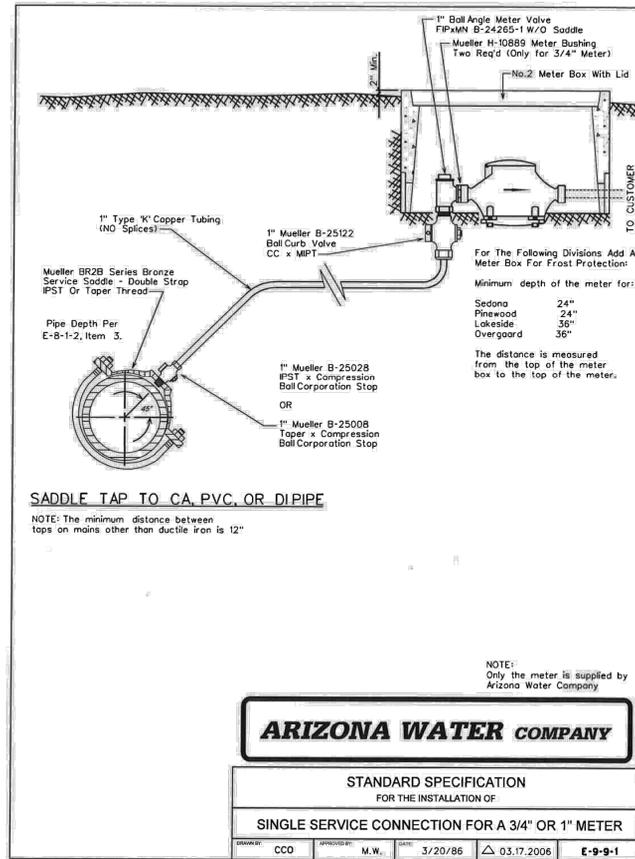

SEE DETAIL H ON DWG C5 FOR FIRE LINE CONNECTION

DETAILS SHOWN ON THIS SHEET HAVE BEEN PREPARED BY ARIZONA WATER COMPANY AND ARE FOR REFERENCE ONLY. IT IS THE CONTRACTOR'S RESPONSIBILITY TO VERIFY THE DETAILS ARE THE LATEST EDITION. SWI IS NOT RESPONSIBLE FOR DETAIL ACCURACY.

FOR REFERENCE ONLY

CITY OF SEDONA ARIZONA		PARK PLACE	
JOB NO. 17186	DATE: AUG 19	SCALE: AS SHOWN	DRAWN: N/A
DESIGN: N/A	CHECKED: N/A	75 Killion Place Sedona, AZ 86336 928.282.2058 fax www.swi.az.com	
 Shephard Wesnitzer, Inc.		REVISIONS NO. DESCRIPTION DATE BY	DRAWING NO. C4 SHT NO. 4 OF 15

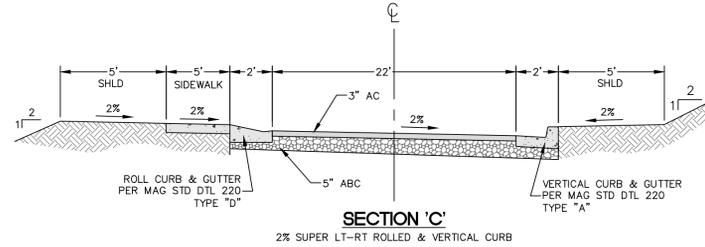
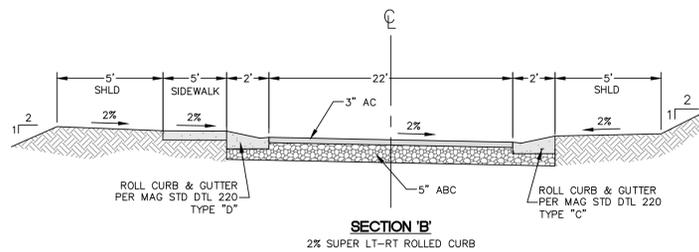
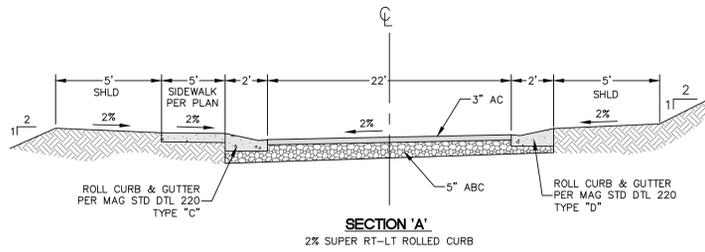

<p>POSITANO - ROADWAY TEMPLATE STATIONS AND TRANSITIONS STA 0+00 TO STA 5+74 - TYPICAL ROADWAY SECTION (A), 2% SUPER RT-LT</p>
<p>PORTOFINO WAY - ROADWAY TEMPLATE STATIONS AND TRANSITIONS STA 3+21 TO STA 5+00 - TYPICAL ROADWAY SECTION (A), 2% SUPER RT-LT STA 5+00 TO STA 5+87 - TRANSITION TO TYPICAL ROADWAY SECTION (B), 2% SUPER LT-RT STA 5+87 TO STA 6+50 - TYPICAL ROADWAY SECTION (B), 2% SUPER LT-RT STA 6+50 TO STA 9+32 - TYPICAL ROADWAY SECTION (C), 2% SUPER LT-RT STA 9+32 TO STA 11+17 - TYPICAL ROADWAY SECTION (B), 2% SUPER LT-RT</p>
<p>DRIVEWAY 1 - ROADWAY TEMPLATE STATIONS AND TRANSITIONS STA 0+00 TO STA 1+00 - TYPICAL ROADWAY SECTION (B), 2% SUPER RT-LT</p>
<p>DRIVEWAY 2 - ROADWAY TEMPLATE STATIONS AND TRANSITIONS STA 0+00 TO STA 1+18 - TYPICAL ROADWAY SECTION (A), 2% SUPER RT-LT</p>

ROAD CROSS SECTIONS (A) NO SCALE

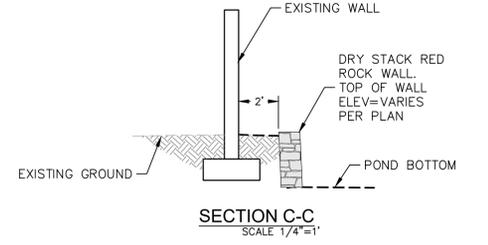
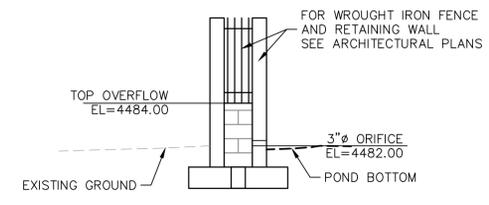
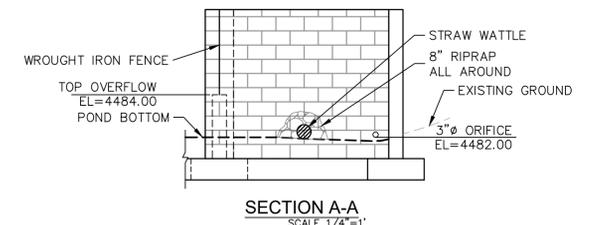
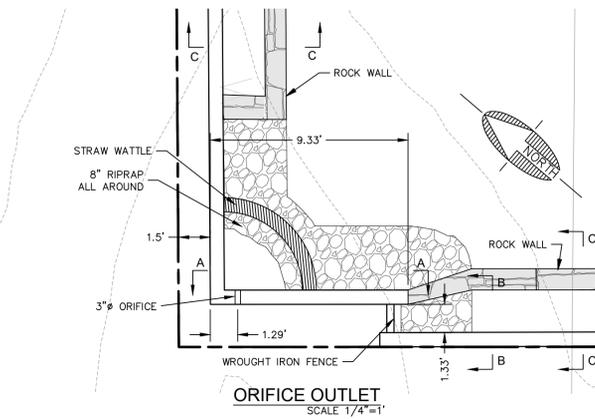
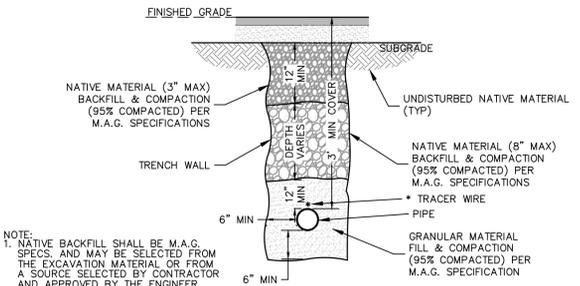
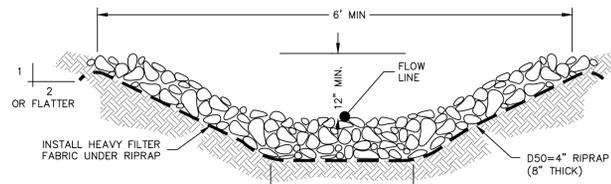
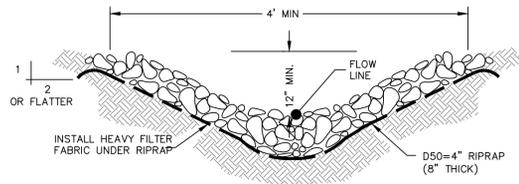
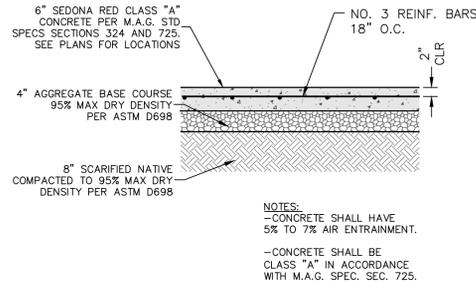
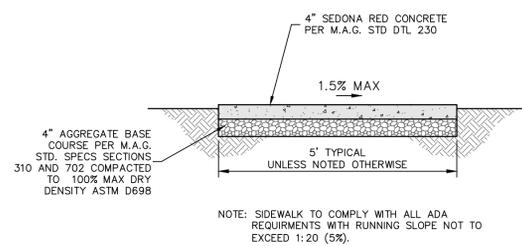

NORTHWEST POND OUTLET DETAIL

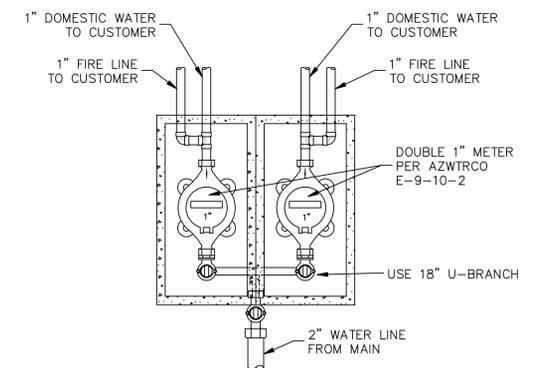

REVISIONS

NO.	DESCRIPTION	DATE	BY

ARIZONA811
Arizona Blue Stakes, Inc.
Call at least two full working days before you begin excavation.
800-841-1111 or 1-800-514-1111 (822-5348)

Shephard Wesnitzer, Inc.

DRAWING NO. C5

SHT NO. 5 OF 15

JOB NO. 17186
DATE: AUG 19
SCALE: AS SHOWN
DRAWN: MWJ
DESIGN: AHB
CHECKED: AHB

PARK PLACE
CITY OF SEDONA ARIZONA

DETAIL SHEET

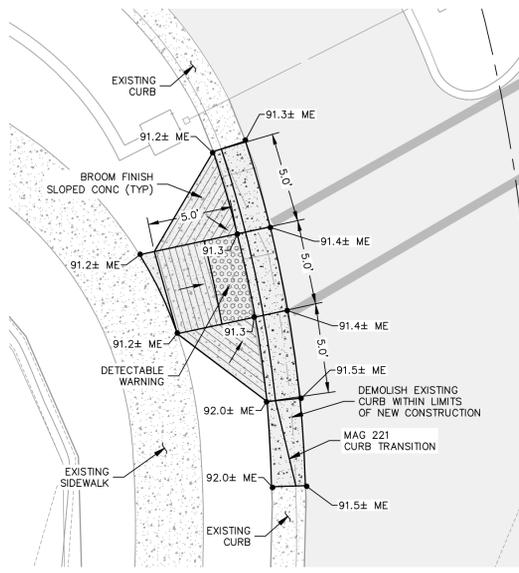

SIDEWALK RAMP DETAIL A
1"=5' C11

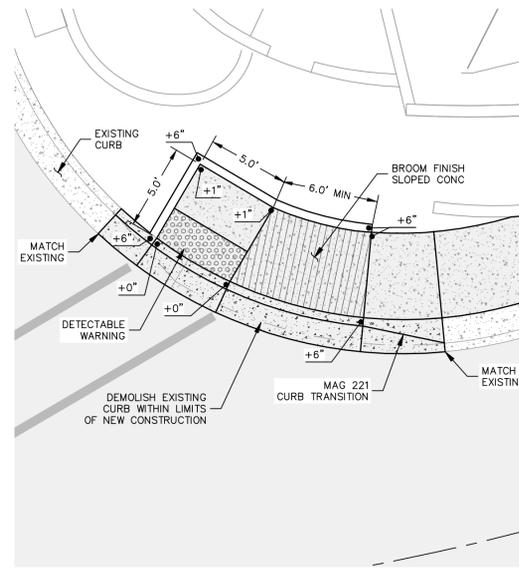

SIDEWALK RAMP DETAIL B
MODIFIED M.A.G. 236-5 SINGLE RAMP 1"=5' C11

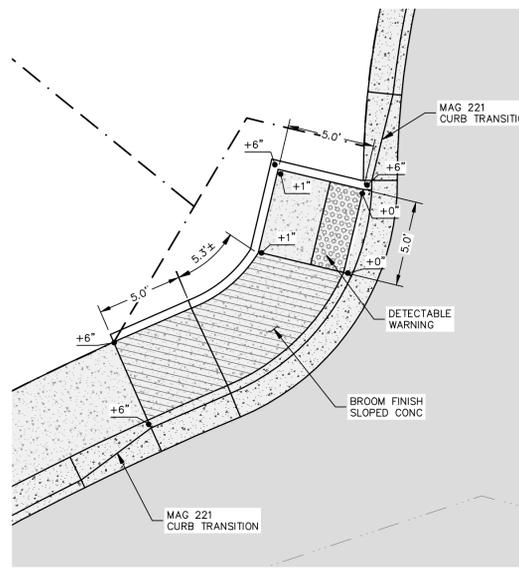

SIDEWALK RAMP DETAIL C
MODIFIED M.A.G. 236-5 SINGLE RAMP 1"=5' C12

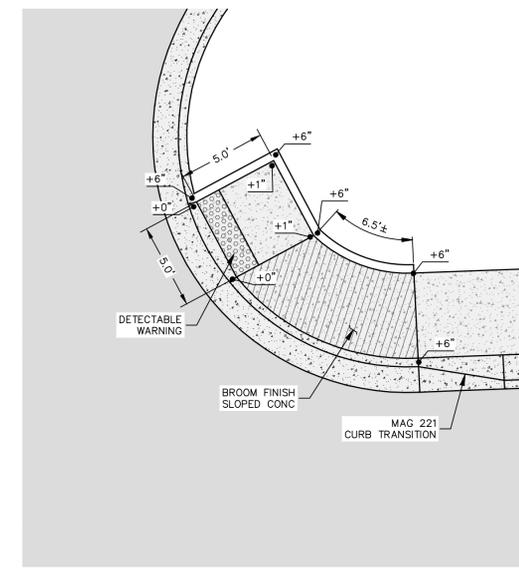

SIDEWALK RAMP DETAIL D
MODIFIED M.A.G. 236-5 SINGLE RAMP 1"=5' C12

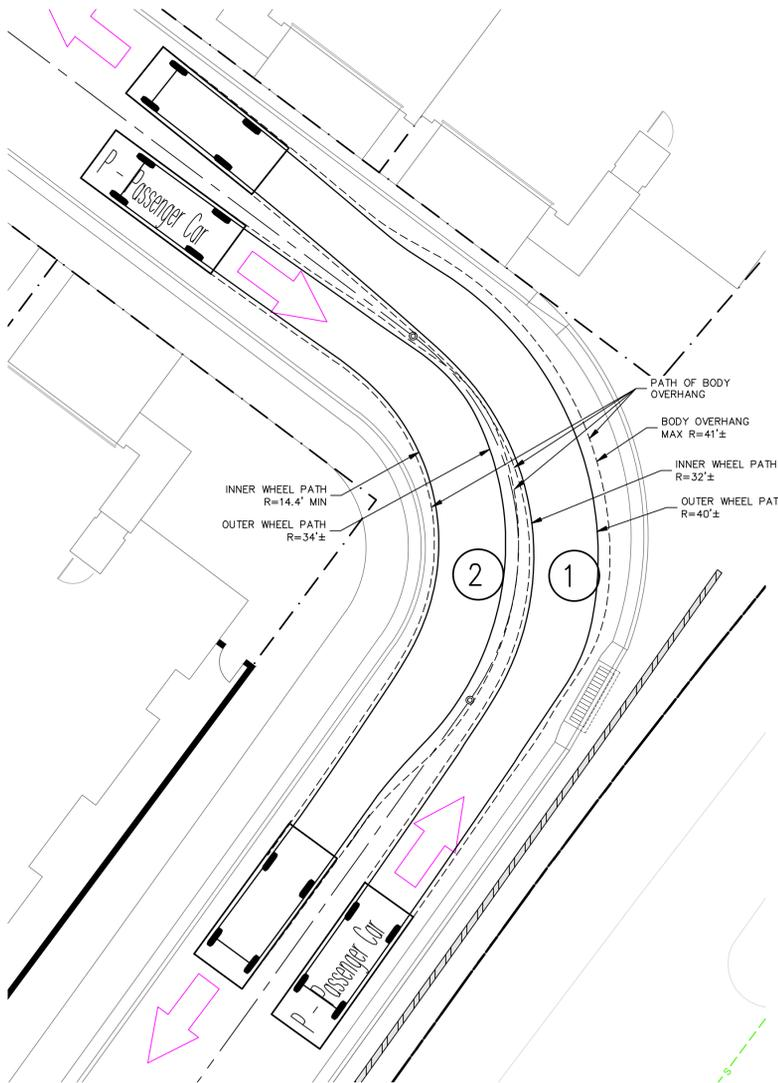

TURN RADIUS DETAIL E
1"=10' C12

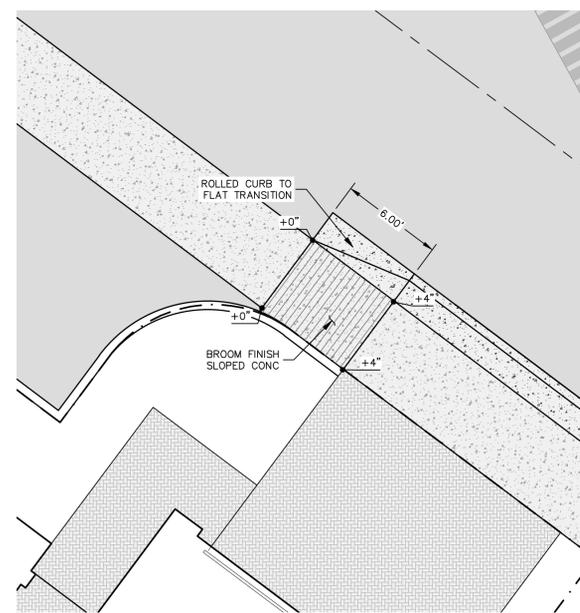

SIDEWALK RAMP DETAIL F
1"=5' C13



CITY OF SEDONA ARIZONA		PARK PLACE		JOB NO: 17186	
DETAIL SHEET				DATE: SEP 19	
				SCALE: AS SHOWN	
				DRAWN: MWJ	
				DESIGN: AHB	
				CHECKED: AHB	
75 Kallist Place Suite 107 928 282 1061 928 282 2058 fax www.swi.cz.com		 Shephard Wesnitzer, Inc.		REVISIONS NO. DESCRIPTION DATE BY	
Call at least two full working days before you begin excavation.  ARIZONA 811 Arizona Blue Stakes, Inc. (888-5348)		DRAWING NO.		SHT NO. OF	
		C6		6 OF 15	

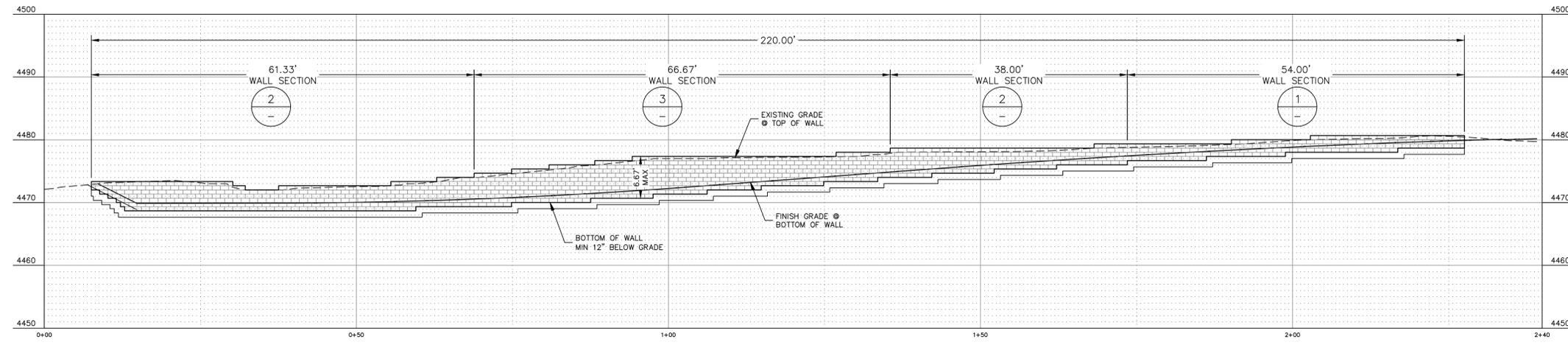

PORTOFINO WALL PROFILE
H=1:10 V=1:10

- RETAINING WALL NOTES**
1. MAX CONTROL JOINT SPACING = 24'
 2. MAX EXPANSION JOINT SPACING = 96'
 3. ALL REINFORCING IN WALLS AND FOOTINGS SHALL BE GRADE 60.
 4. FILL ALL CELLS WITH GROUT. PLACE 1 CUBIC FOOT OF LEACH ROCK WRAPPED IN FILTER FABRIC PER LINEAL FOOT OF WALL WITH 3" SCH 40 PVC WEEP PIPE @ 6' O.C. FOR DRAINAGE.
 5. PLACE VERTICAL STEEL ON EACH SIDE OF CONTROL JOINTS AND EXPANSION JOINTS.
 6. CONCRETE FOR ALL RETAINING WALLS SHALL BE CLASS "A" COMPRESSIVE STRENGTH $f'_c = 3000$ PSI AT 28 DAYS.
 7. WALL FOOTINGS SHALL HAVE AT LEAST 24" OF COVER ABOVE THE BOTTOM OF FOOTING.
 8. FOR OVER-EXCAVATION AND RE-COMPACTION REQUIREMENTS UNDER FOOTINGS REFERENCE GEOTECHNICAL REPORT.
 9. GROUT SHALL ATTAIN A MINIMUM COMPRESSIVE STRENGTH AT 28 DAYS OF 2000 PSI.
 10. FILL BEHIND WALLS TO CONFORM TO "COMPACTED GRANULAR BACKFILL" OR "COMPACTED SITE SOILS (NON CLAY)" PER GEOTECHNICAL EVALUATION.

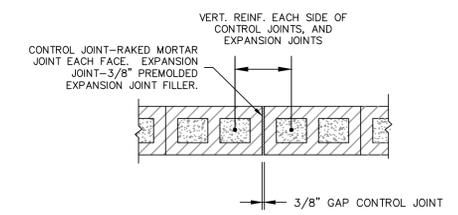

CONTROL JOINT DETAIL
N.T.S.

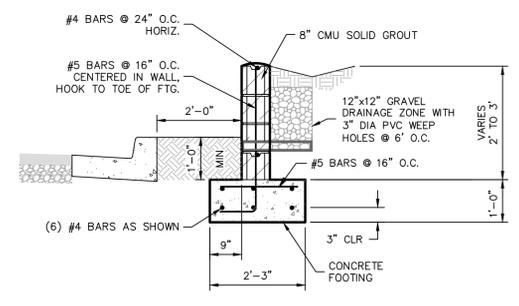

2' TO 3' RETAINING WALL (1)
1/2"=1'-0"

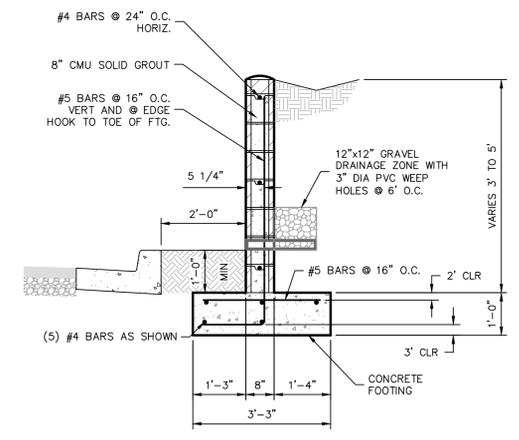

3' TO 5' RETAINING WALL (2)
1/2"=1'-0"

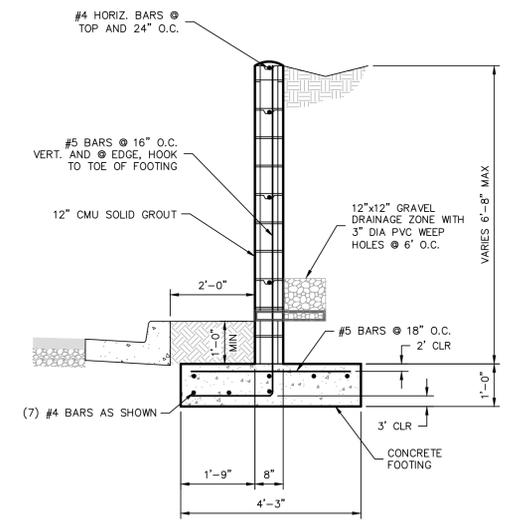

5' TO 7' RETAINING WALL (3)
1/2"=1'-0"

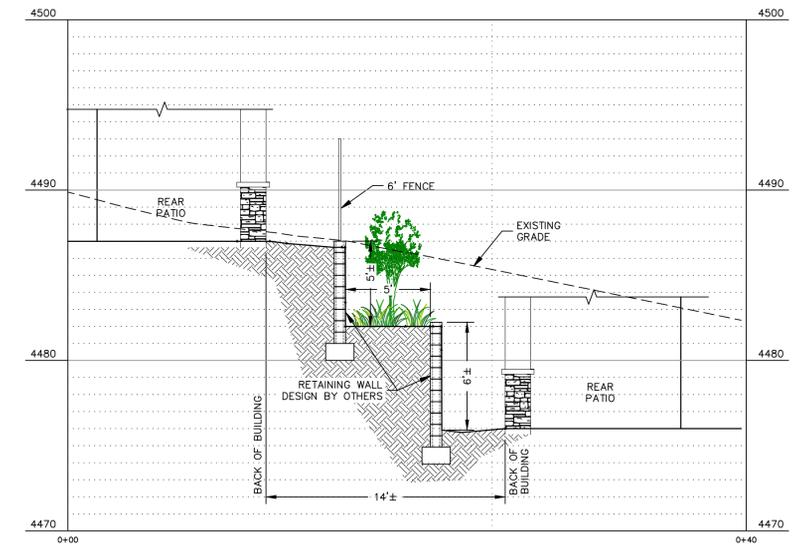

WALL CROSS SECTION (4)
1"=5' (C12)

CITY OF SEDONA ARIZONA
PARK PLACE

JOB NO. 17186	DATE: AUG 19	SCALE: AS SHOWN	DESIGN: AHB	CHECKED: AHB
75 Killion Place Sedona, AZ 86336 Phone: 928.282.1101 928.282.2058 fax www.swi.coz.com				

SWI
Shephard Wesnitzer, Inc.

NO.	REVISIONS	DATE	BY

Call at least two full working days before you begin excavation.
ARIZONA 811
Arizona Blue Stakes, Inc. (928-5348)
Dial 8-1-1 or 1-800-514-1111 (928-5348)

REGISTERED PROFESSIONAL ENGINEER
28658
ARTHUR H. BECKWITH
Signed: 08/08/19
Exp: 08/08/20

DRAWING NO. **C7**

SHT NO. 7 OF 15

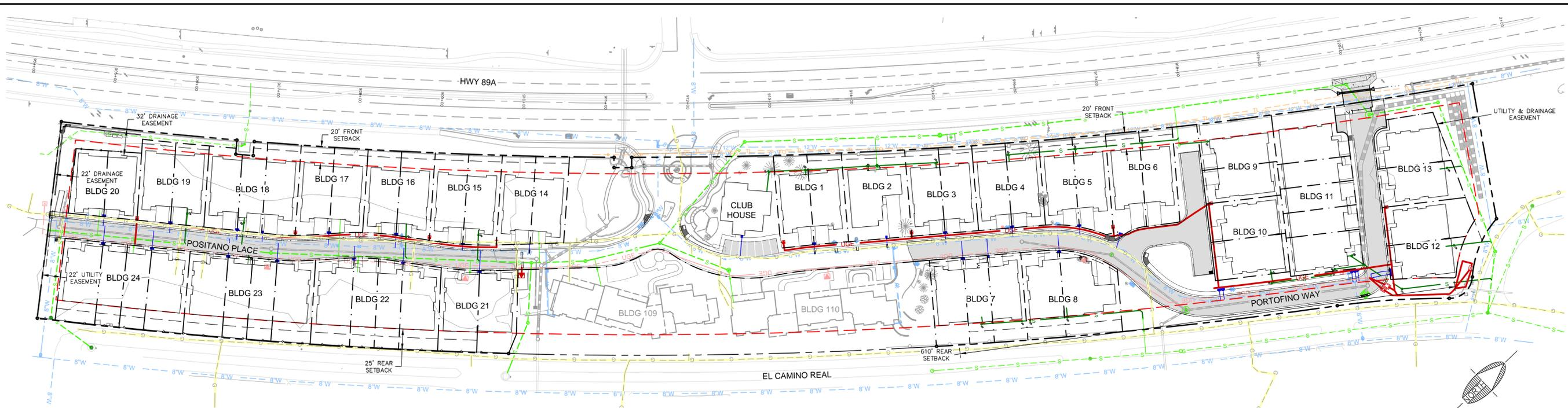

UTILITY PLAN
1"=60'

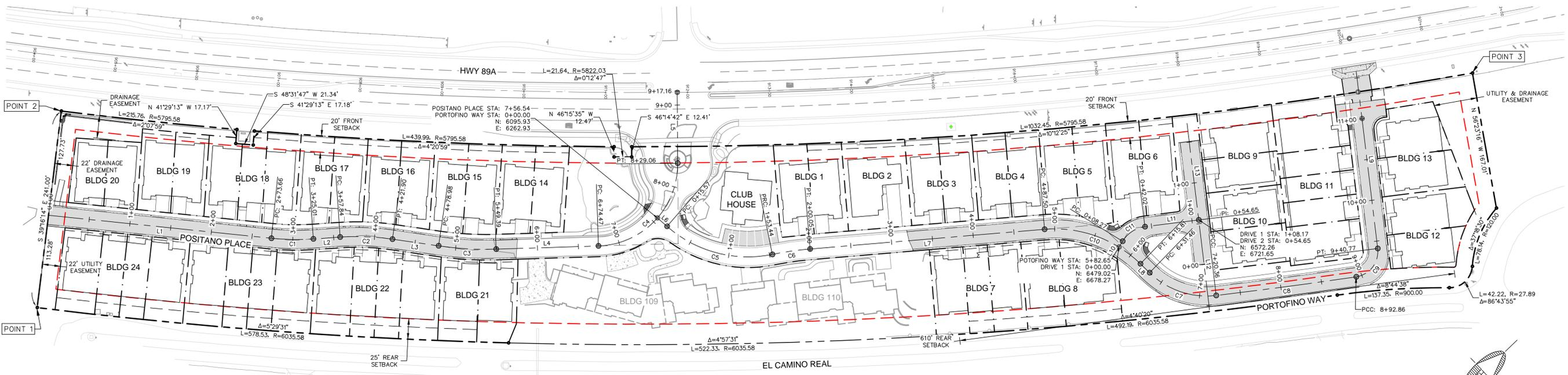

SURVEY CONTROL PLAN
1"=60'

LINE TABLE				
Line #	Length	Direction	Start Point	End Point
L1	273.66	N 49°35'24" E	5746.37,5560.49	5954.75,5737.89
L2	32.83	N 39°46'59" E	5990.81,5774.35	6011.82,5799.58
L3	57.07	N 52°01'07" E	6057.74,5844.08	6102.72,5879.20
L4	125.07	N 41°55'56" E	6154.13,5927.18	6237.72,6020.23
L5	88.10	N 46°38'40" W	6231.98,6159.77	6167.92,6220.25
L6	15.57	N 84°54'32" E	6282.93,6095.93	6278.44,6097.31
L7	287.45	N 38°55'34" E	6419.10,6204.57	6599.71,6428.19
L8	15.64	N 87°56'14" E	6711.01,6483.85	6726.64,6484.41
L9	217.45	N 53°11'50" W	6898.02,6706.16	6723.91,6836.43
L10	34.10	N 14°43'46" W	6684.83,6454.04	6676.16,6487.01
L11	66.15	N 36°28'50" E	6682.32,6519.06	6721.65,6572.26
L12	110.31	N 53°11'50" W	6809.98,6506.17	6721.65,6572.26
L13	118.38	N 53°11'50" W	6721.65,6572.26	6626.87,6643.17

CURVE TABLE						
Curve #	Radius	Length	DELTA	Chord Direction	Start Point	End Point
C1	300.00	51.35	Δ=9°48'24"	N 44°11'11" E	5954.75,5737.89	5990.81,5774.35
C2	300.00	64.06	Δ=12°14'08"	N 45°54'03" E	6011.82,5799.58	6057.74,5844.08
C3	400.00	70.42	Δ=10°05'10"	N 46°58'32" E	6102.72,5879.20	6154.13,5927.18
C4	100.00	154.60	Δ=88°34'37"	N 2°21'22" W	6237.72,6020.23	6231.98,6159.77
C5	150.00	137.86	Δ=52°39'37"	N 58°34'43" E	6278.44,6097.31	6391.99,6166.68
C6	400.00	46.62	Δ=6°40'40"	N 35°35'14" E	6391.99,6166.68	6419.10,6204.57
C7	100.00	88.90	Δ=50°56'10"	N 62°28'09" E	6726.64,6484.41	6802.90,6524.16
C8	6016.91	172.50	Δ=1°38'34"	N 36°10'47" E	6802.90,6524.16	6904.73,6663.40
C9	31.00	47.91	Δ=88°33'21"	N 8°55'10" W	6904.73,6663.40	6898.02,6706.16
C10	150.00	128.31	Δ=49°00'40"	N 63°25'54" E	6599.71,6428.19	6711.01,6483.85
C11	37.76	33.75	Δ=51°12'36"	N 10°52'32" E	6676.16,6487.01	6682.32,6519.06

ARIZONA

PARK PLACE

OVERALL UTILITY PLAN & SURVEY CONTROL

JOB NO: 17186
DATE: AUG 19
SCALE: AS SHOWN
DRAWN: MWJ
DESIGN: AHB
CHECKED: AHB

75 Killet Place
Suite 107
Phoenix, AZ 85034
928.282.1068 fax
928.282.2058
www.swi.cz.com

SWI
Shephard Westnitzer, Inc.

NO.	DESCRIPTION	DATE	BY

Call out at least two full working days before you begin excavation.

ARIZONA
Professional Engineer
28658
ARTHUR H. BECKWITH
Exp. 08/28/19

DRAWING NO.
C8

SHT NO. 8 OF 15

PLOTTED: Aug 08, 2019--11:21am

FILE: P:\2017\17186\DRAWINGS\CONSTRUCTION PLANS\17186- ROADWAY - 01.DWG MJJING

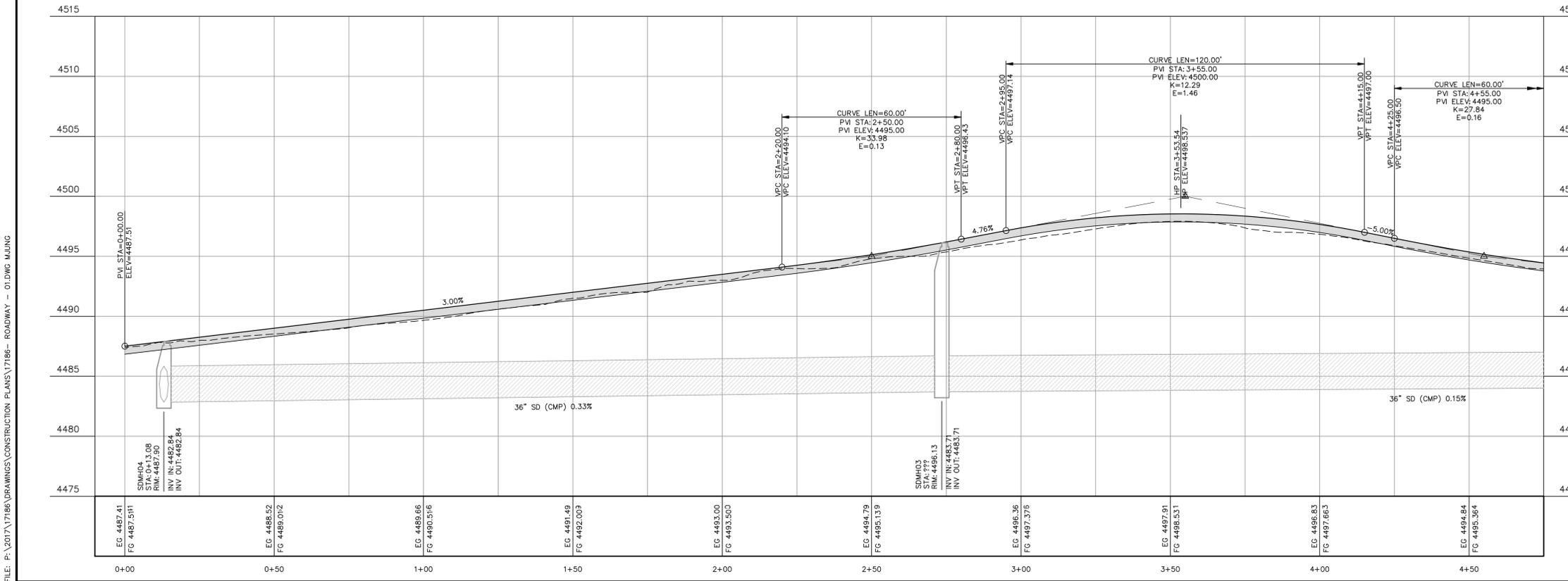
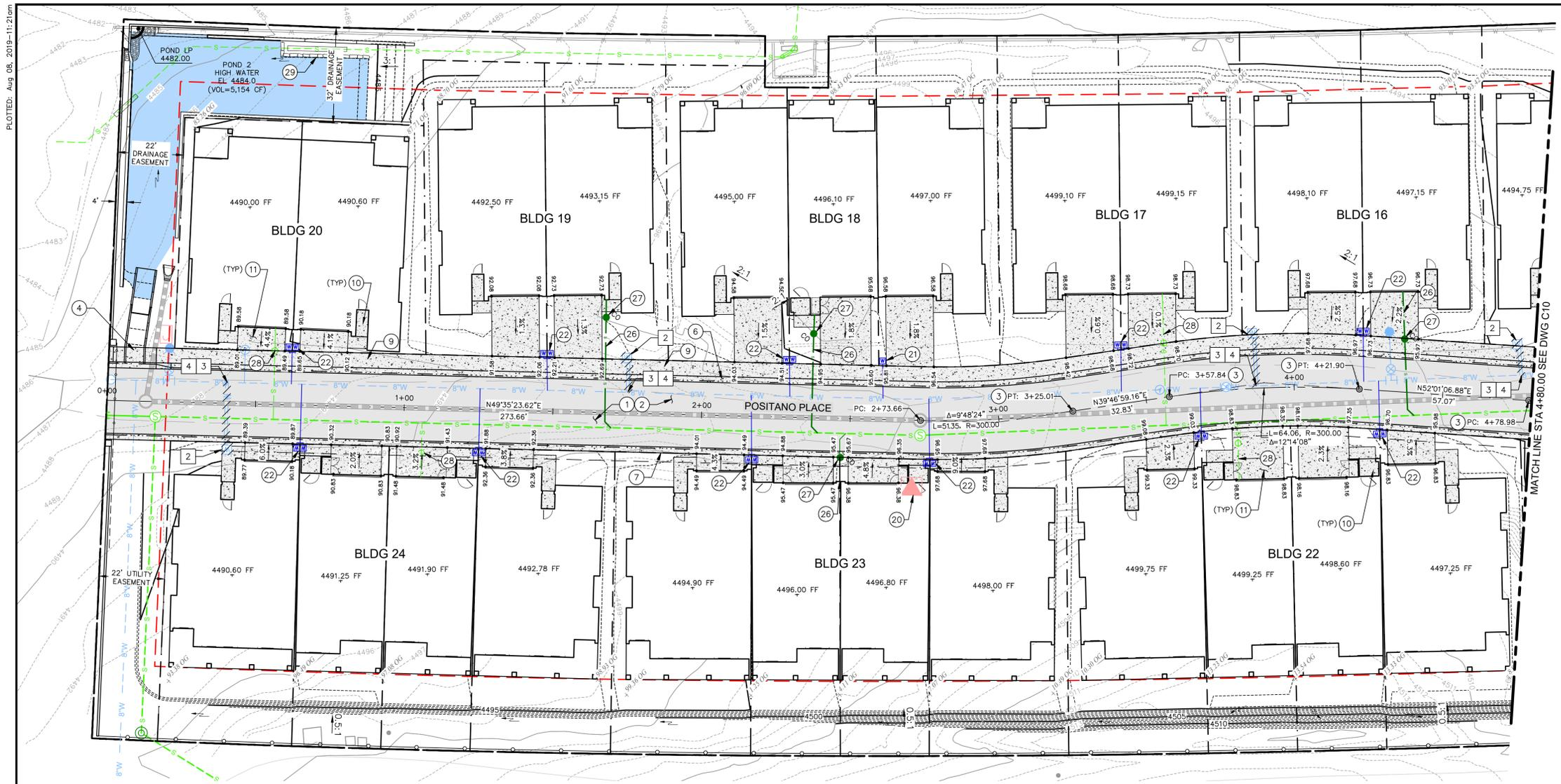

- DEMOLITION NOTES**
- REMOVE EXISTING 2" WATER SERVICE & 4" FIRE SERVICE PER ARIZONA WATER COMPANY REQUIREMENTS.
 - REMOVE VALVE ON FIRE AND USE A BLIND FLANGE CAP ON THE 4" TEE.
 - REMOVE 2" SERVICE SADDLE AND CORP STOP AND USE REPAIR CLAMP OVER EXISTING HOLE.
- CONSTRUCTION NOTES**
- SUBGRADE PREPARATION
 - CONSTRUCT ASPHALT PAVEMENT & SUBGRADE PER TYPICAL ROADWAY SECTION ON DWG C5
 - CENTERLINE STREET MONUMENTS PER M.A.G. STD. DETAIL 120-1 TYPE B.
 - CONSTRUCT CONCRETE SCUPPER PER M.A.G. STD. DETAIL 206
 - CONSTRUCT TYPE 'A' VERTICAL CURB & GUTTER PER M.A.G. STD. DETAIL 220
 - CONSTRUCT TYPE 'C' ROLL CURB & GUTTER PER M.A.G. STD. DETAIL 220
 - CONSTRUCT TYPE 'D' ROLL CURB & GUTTER PER M.A.G. STD. DETAIL 220
 - CONSTRUCT CURB TRANSITION PER M.A.G. STD. DETAIL 221
 - CONSTRUCT 5' SIDEWALK PER M.A.G. STD. DETAIL 230
 - CONSTRUCT 3' WALKWAY PER DETAIL ON DWG C5
 - CONSTRUCT CONCRETE DRIVEWAY 4" THICK OVER 4" ABC
 - RELOCATE EXISTING APS TRANSFORMER PER UTILITY
 - INSTALL 1" SINGLE WATER SERVICE CONNECTION WITH 1" METER PER AZ WTR CO. STANDARD DETAIL E-9-9-1. ADD 1" FIRE SUPPLY LINE PER DETAIL 'J'/C5
 - INSTALL 2" DOUBLE WATER SERVICE CONNECTION WITH 1" METERS PER AZ WTR CO. STANDARD DETAIL E-9-10-2. ADD 1" FIRE SUPPLY LINE PER DETAIL 'H'/C5
 - INSTALL 6" PVC SEWER SERVICE
 - INSTALL SEWER CLEANOUT
 - CONNECT TO EXISTING SEWER STUB
 - CONCRETE ENCASE EXIST 12" FOUL AIR PIPING AND CONSTRUCT DRY STACK ROCK WALL TO MAINTAIN MIN 12" COVER.

GENERAL NOTES:
 ALL STATIONING TO BE SET ALONG THE CENTERLINE OF STREETS, AND WILL BE USED TO DETERMINE THE LOCATION OF FIRE HYDRANTS, CULVERTS, ETC.
 THE INFORMATION ON THESE CONSTRUCTION PLANS CONCERNING THE TYPE, SIZE & LOCATION OF UTILITIES HAS BEEN BASED ON THE BEST INFORMATION AVAILABLE. THE CONTRACTOR SHALL BE RESPONSIBLE FOR DETERMINATION OF EXACT LOCATION OF ALL EXISTING UTILITIES PRIOR TO CONSTRUCTION. IT IS THE CONTRACTORS RESPONSIBILITY TO PROTECT ALL EXISTING UTILITIES, IN PLACE, UNLESS OTHERWISE NOTED OR SPECIFIED.

Call at least two full working days before you begin excavation.

ARIZONA 811
 Arizona Blue Stakes, Inc. (888-5348)
 888-8-1-1 or 1-800-534-8111 (888-5348)

Professional Engineer Seal:
 ARTHUR H. BECKWITH
 No. 28658
 Exp. 08/31/19

REVISIONS:

NO.	DESCRIPTION	DATE	BY

DRAWING NO. C9

SHT NO. 9 OF 15

SWI
 Shephard Wesnitzer, Inc.

221 N. Maricopa St.
 Suite 102
 Prescott, AZ 86301
 928.541.0443
 928.541.1075 fax
 www.swi-gz.com

CITY OF SEDONA
ARIZONA

PARK PLACE

JOB NO: 17186
 DATE: AUG 19
 SCALE: H=1:20 V=1:10
 DRAWN: MWJ
 DESIGN: AHB
 CHECKED: AHB

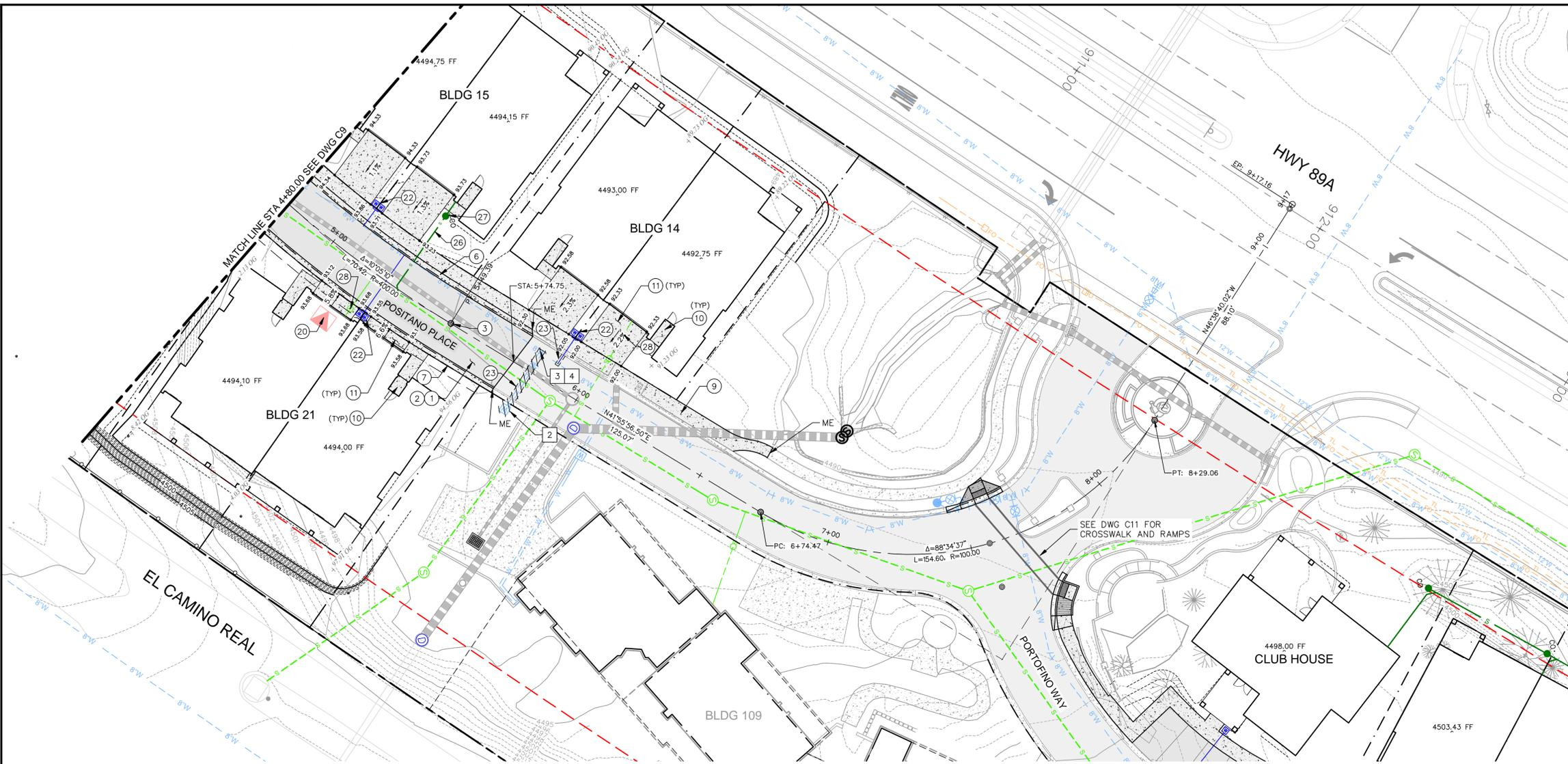

- DEMOLITION NOTES**
- 2 REMOVE EXISTING 2" WATER SERVICE & 4" FIRE SERVICE PER ARIZONA WATER COMPANY REQUIREMENTS.
 - 3 REMOVE VALVE ON FIRE AND USE A BLIND FLANGE CAP ON THE 4" TEE.
 - 4 REMOVE 2" SERVICE SADDLE AND CORP STOP AND USE REPAIR CLAMP OVER EXISTING HOLE.

- CONSTRUCTION NOTES**
- 1 SUBGRADE PREPARATION
 - 2 CONSTRUCT ASPHALT PAVEMENT & SUBGRADE PER TYPICAL ROADWAY SECTION ON DWG C5
 - 3 CENTERLINE STREET MONUMENTS PER M.A.G. STD. DETAIL 120-1 TYPE B.
 - 6 CONSTRUCT TYPE 'C' ROLL CURB & GUTTER PER M.A.G. STD. DETAIL 220
 - 7 CONSTRUCT TYPE 'D' ROLL CURB & GUTTER PER M.A.G. STD. DETAIL 220
 - 9 CONSTRUCT 5' SIDEWALK PER M.A.G. STD. DETAIL 230
 - 10 CONSTRUCT 3' WALKWAY PER DETAIL ON DWG C5
 - 11 CONSTRUCT CONCRETE DRIVEWAY 4" THICK OVER 4" ABC
 - 20 RELOCATE EXISTING APS TRANSFORMER PER UTILITY
 - 22 INSTALL 2" DOUBLE WATER SERVICE CONNECTION WITH 1" METERS PER AZ WTR CO. STANDARD DETAIL E-9-10-2. ADD 1" FIRE SUPPLY LINE PER DETAIL 'H'/C5
 - 23 SAWCUT AND TRENCH REPAIR ASPHALT PER M.A.G. STANDARD DETAIL 200-1 TYPE 'B'
 - 26 INSTALL 6" PVC SEWER SERVICE
 - 27 INSTALL SEWER CLEANOUT
 - 28 CONNECT TO EXISTING SEWER STUB

CITY OF SEDONA
ARIZONA

PARK PLACE

POSITANO PLACE PLAN & PROFILE

JOB NO: 17186
DATE: AUG 19
SCALE: H=1:20 V=1:10
DRAWN: MWJ
DESIGN: AHB
CHECKED: AHB

221 N. Moring St.
Suite 102
Prescott, AZ 86301
928.541.0443
928.541.1075 fax
www.swigz.com

SWI
Shephard Wesnitzer, Inc.

NO.	DESCRIPTION	DATE	BY

Call at least two full working days before you begin excavation.

ARIZONA 811
Arizona Blue Stake, Inc. (928-5348)

Professional Engineer
28558
ARTHUR H. BECKWITH
Signed: 08/28/19
Seal: 08/28/19

DRAWING NO. **C10**

SHT NO. 10 OF 15

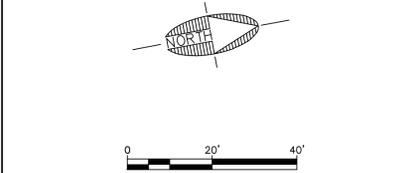
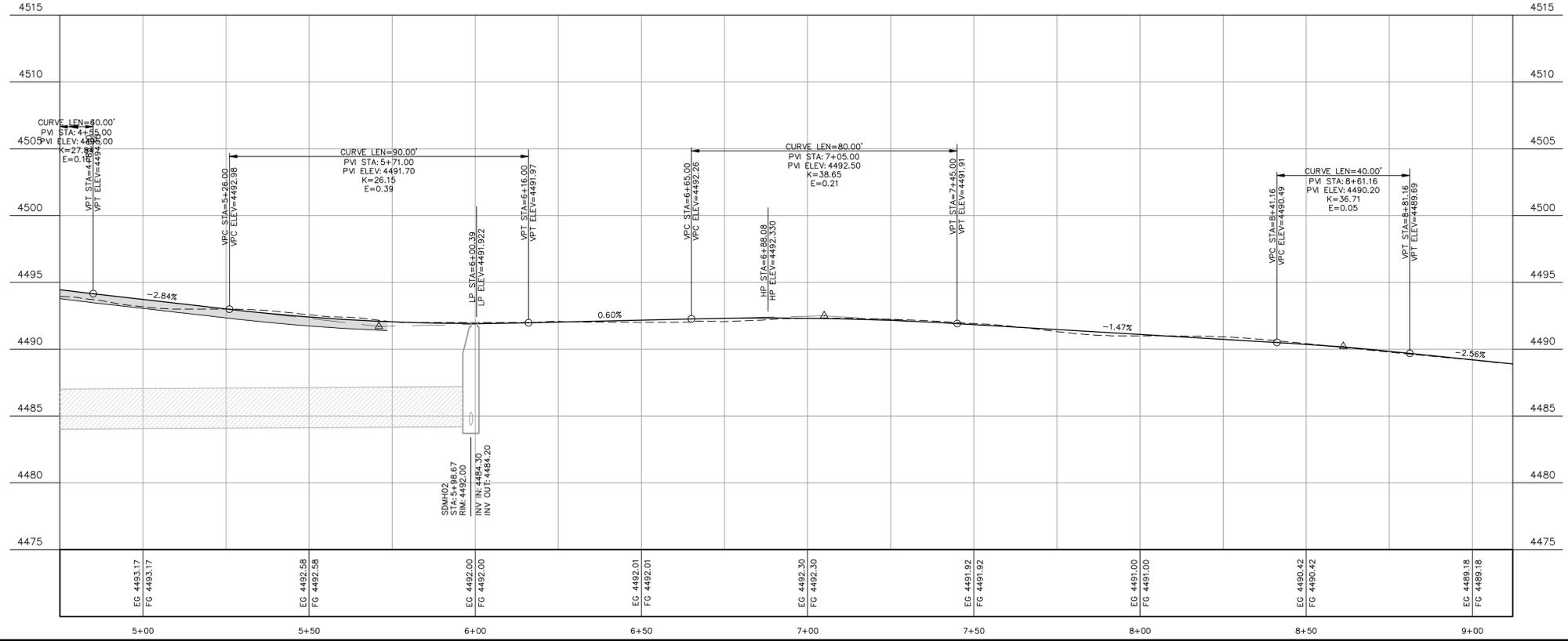

GENERAL NOTES:
ALL STATIONING TO BE SET ALONG THE CENTERLINE OF STREETS, AND WILL BE USED TO DETERMINE THE LOCATION OF FIRE HYDRANTS, CULVERTS, ETC.

THE INFORMATION ON THESE CONSTRUCTION PLANS CONCERNING THE TYPE, SIZE & LOCATION OF UTILITIES HAS BEEN BASED ON THE BEST INFORMATION AVAILABLE. THE CONTRACTOR SHALL BE RESPONSIBLE FOR DETERMINATION OF EXACT LOCATION OF ALL EXISTING UTILITIES PRIOR TO CONSTRUCTION. IT IS THE CONTRACTOR'S RESPONSIBILITY TO PROTECT ALL EXISTING UTILITIES, IN PLACE, UNLESS OTHERWISE NOTED OR SPECIFIED.

PLOTTED: Aug 28, 2019 - 12:01pm

FILE: P:\2017\17186\DRAWINGS\17186 - PARK PLACE (COS SUBMITTAL)\C3D\17186- ROADWAY - 02.DWG MJUNG

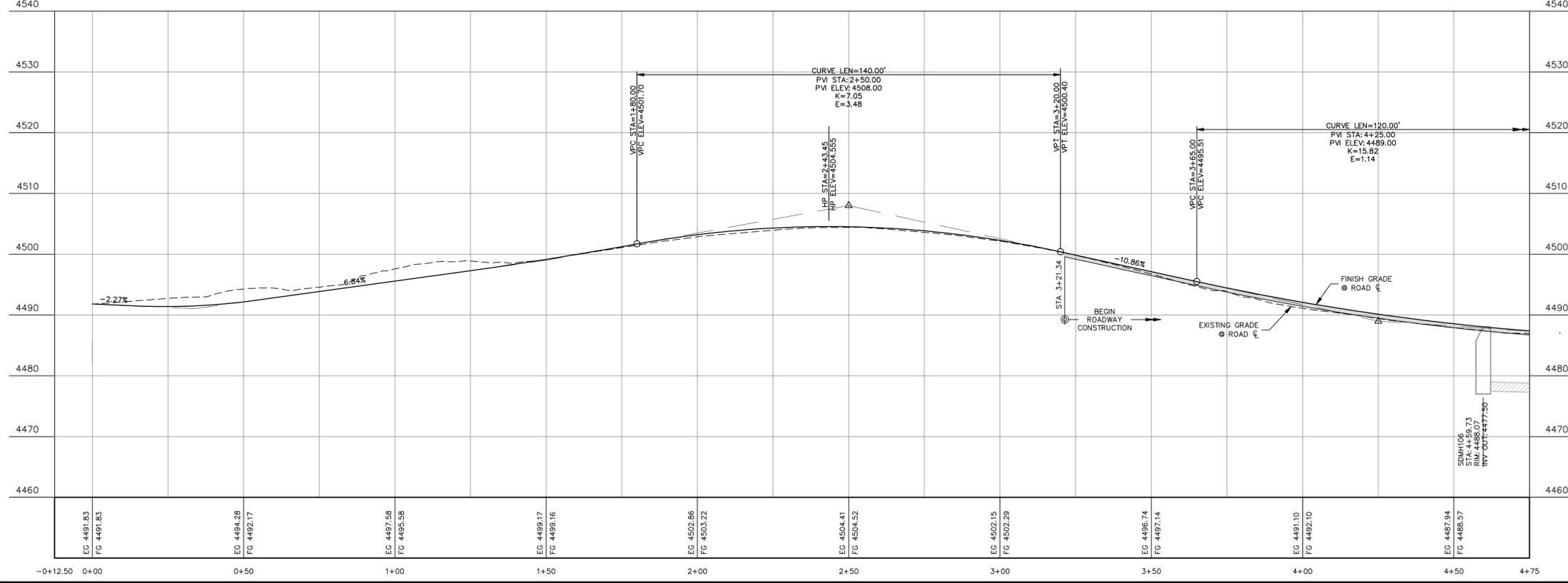
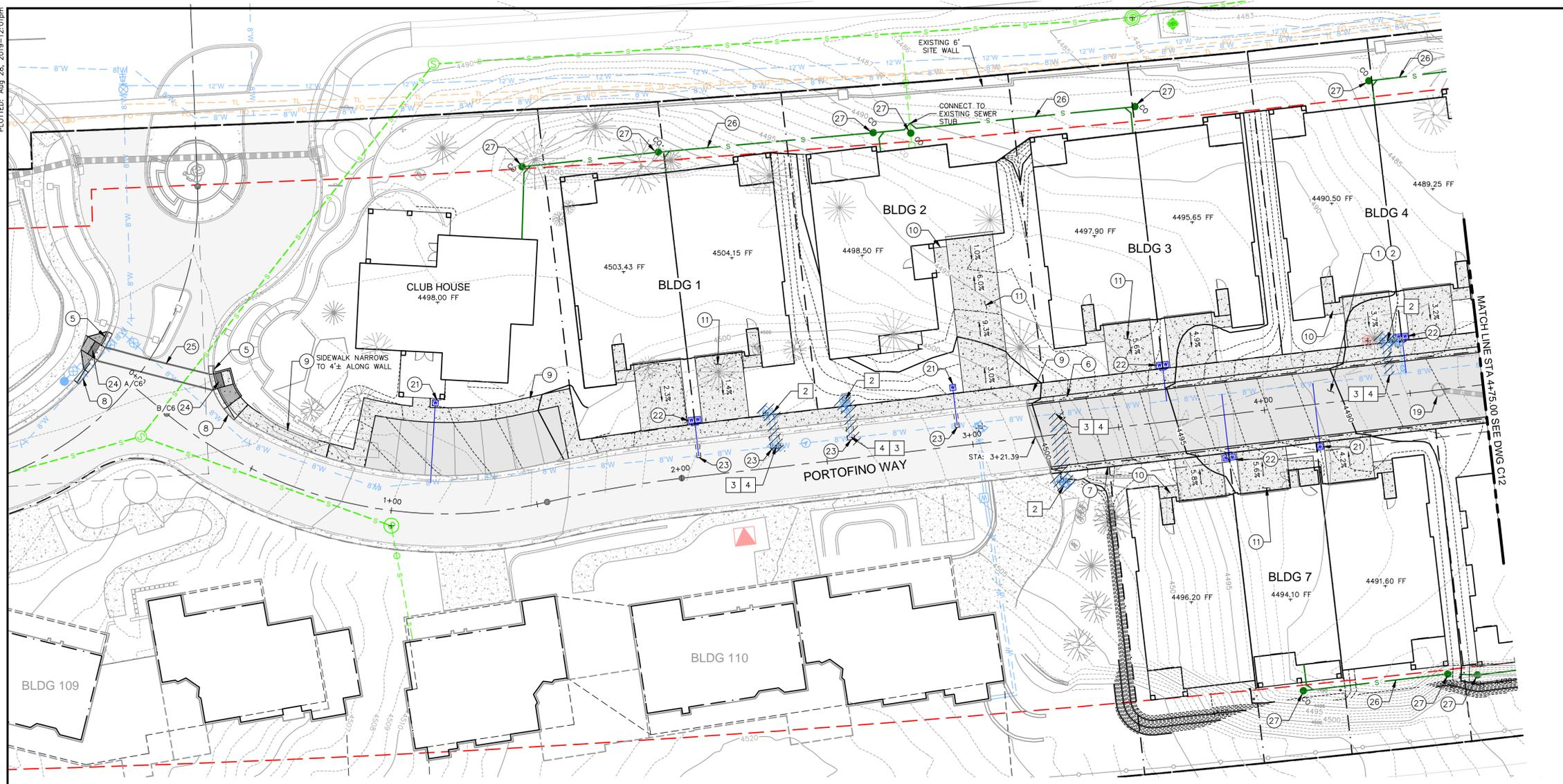

- ### DEMOLITION NOTES
- CLEAR AND GRUB
 - REMOVE EXISTING 2" WATER SERVICE & 4" FIRE SERVICE PER ARIZONA WATER COMPANY REQUIREMENTS.
 - REMOVE VALVE ON FIRE AND USE A BLIND FLANGE CAP ON THE 4" TEE.
 - REMOVE 2" SERVICE SADDLE AND CORP STOP AND USE REPAIR CLAMP OVER EXISTING HOLE.
- ### CONSTRUCTION NOTES
- SUBGRADE PREPARATION
 - CONSTRUCT ASPHALT PAVEMENT & SUBGRADE PER TYPICAL ROADWAY SECTION ON DWG C5
 - CONSTRUCT TYPE 'A' VERTICAL CURB & GUTTER PER M.A.G. STD. DETAIL 220
 - CONSTRUCT TYPE 'C' ROLL CURB & GUTTER PER M.A.G. STD. DETAIL 220
 - CONSTRUCT TYPE 'D' ROLL CURB & GUTTER PER M.A.G. STD. DETAIL 220
 - CONSTRUCT CURB TRANSITION PER M.A.G. STD. DETAIL 221
 - CONSTRUCT 5' SIDEWALK PER M.A.G. STD. DETAIL 230
 - CONSTRUCT 3' WALKWAY PER DETAIL ON DWG C5
 - CONSTRUCT CONCRETE DRIVEWAY 4" THICK OVER 4" ABC
 - ADJUST MANHOLE TO GRADE PER M.A.G. STD. DETAIL 270
 - INSTALL 1" SINGLE WATER SERVICE CONNECTION WITH 1" METER PER AZ WTR CO. STANDARD DETAIL E-9-9-1. ADD 1" FIRE SUPPLY LINE PER DETAIL 'J'/C5
 - INSTALL 2" DOUBLE WATER SERVICE CONNECTION WITH 1" METERS PER AZ WTR CO. STANDARD DETAIL E-9-10-2. ADD 1" FIRE SUPPLY LINE PER DETAIL 'H'/C5
 - SAWCUT AND TRENCH REPAIR ASPHALT PER M.A.G. STANDARD DETAIL 200-1 TYPE 'B'
 - CONSTRUCT SIDEWALK RAMP PER DETAILS ON C6.
 - INSTALL 6" WHITE CROSSWALK STRIPING SPACED 5' APART.
 - INSTALL 6" PVC SEWER SERVICE
 - INSTALL SEWER CLEANOUT

GENERAL NOTES:
 ALL STATIONING TO BE SET ALONG THE CENTERLINE OF STREETS, AND WILL BE USED TO DETERMINE THE LOCATION OF FIRE HYDRANTS, CULVERTS, ETC.
 THE INFORMATION ON THESE CONSTRUCTION PLANS CONCERNING THE TYPE, SIZE & LOCATION OF UTILITIES HAS BEEN BASED ON THE BEST INFORMATION AVAILABLE. THE CONTRACTOR SHALL BE RESPONSIBLE FOR DETERMINATION OF EXACT LOCATION OF ALL EXISTING UTILITIES PRIOR TO CONSTRUCTION. IT IS THE CONTRACTORS RESPONSIBILITY TO PROTECT ALL EXISTING UTILITIES, IN PLACE, UNLESS OTHERWISE NOTED OR SPECIFIED.

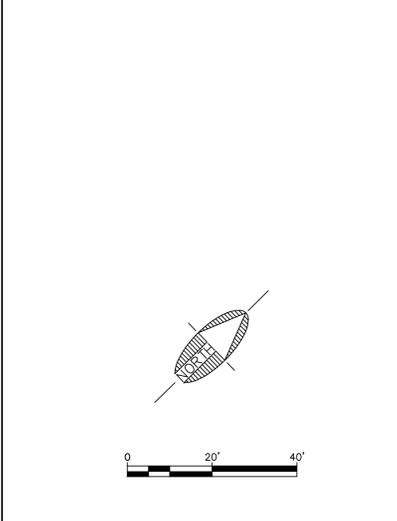

Call out least two full working days before you begin excavation.
ARIZONA 811
 Arizona Blue Stakes, Inc. (928-5348)
 088 8-1-1 or 1-800-5348-11 (928-5348)

Professional Engineer Seal:
 Registered Professional Engineer
 28658
 ARTHUR H. BECKWITH
 State of Arizona
 Exp. 08/28/19
 Colby Padgett

CITY OF SEDONA
 ARIZONA

PARK PLACE

PORTOFINO WAY PLAN & PROFILE

JOB NO: 17186
 DATE: AUG 19
 SCALE: H=1:20 V=1:10
 DRAWN: MWJ
 DESIGN: AHB
 CHECKED: AHB

221 N. Moring St.
 Suite 102
 Prescott, AZ 86301
 928.541.0443
 928.541.1075 fax
 www.swigz.com

SWI
 Shephard Wesnitzer, Inc.

NO.	DESCRIPTION	DATE	BY

DRAWING NO. **C11**

SHT NO. 11 OF 15

PLOTTED: Aug 08, 2019--11:23am

FILE: P:\2017\1786\DRAWINGS\C3D\1786- ROADWAY - 02.DWG MJUNG

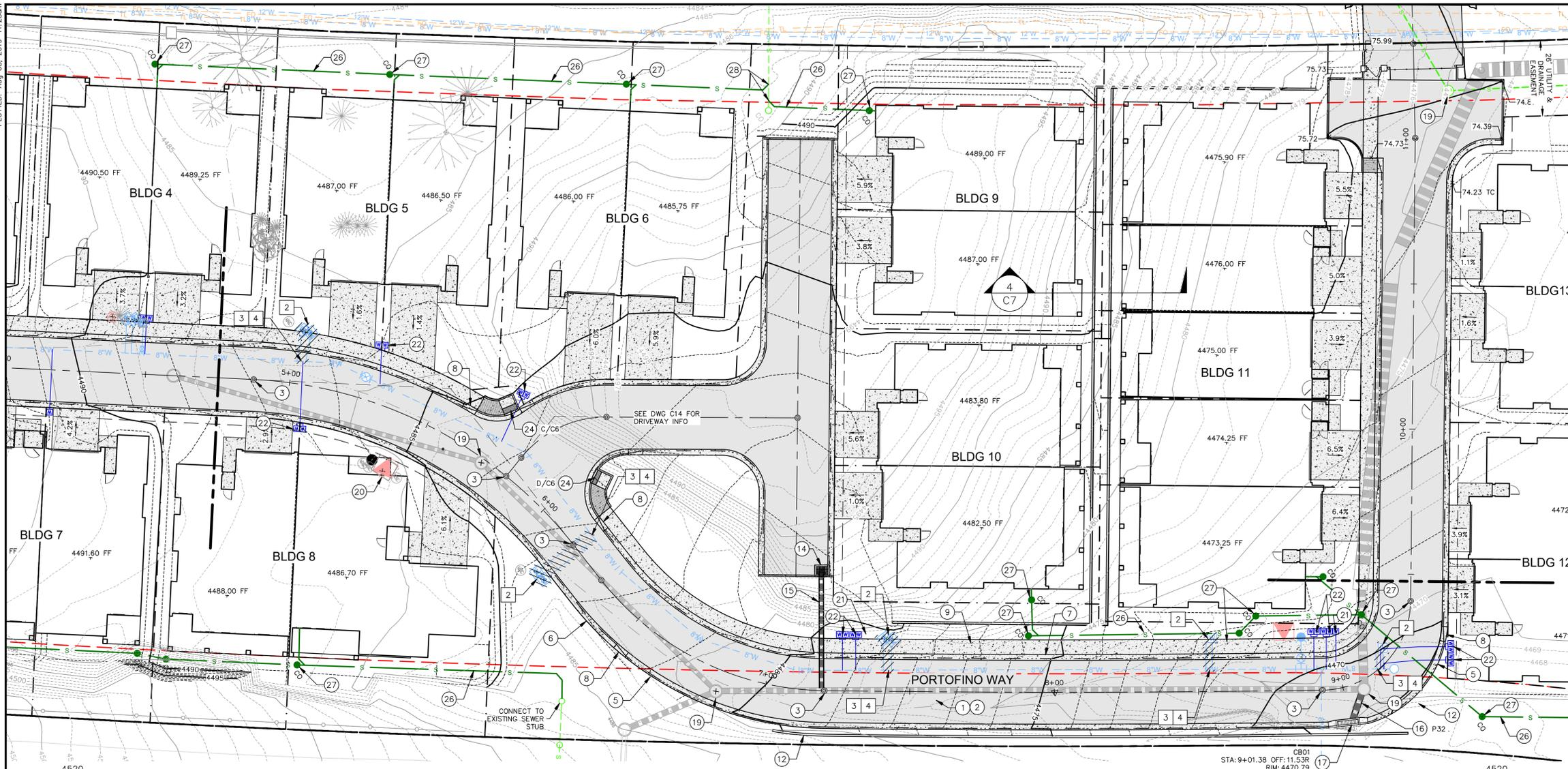

C801
STA: 9+01.38 OFF: 11.53R
RIM: 4470.79
SUMP: 4465.00
INV OUT: 4465.00 24" CMP

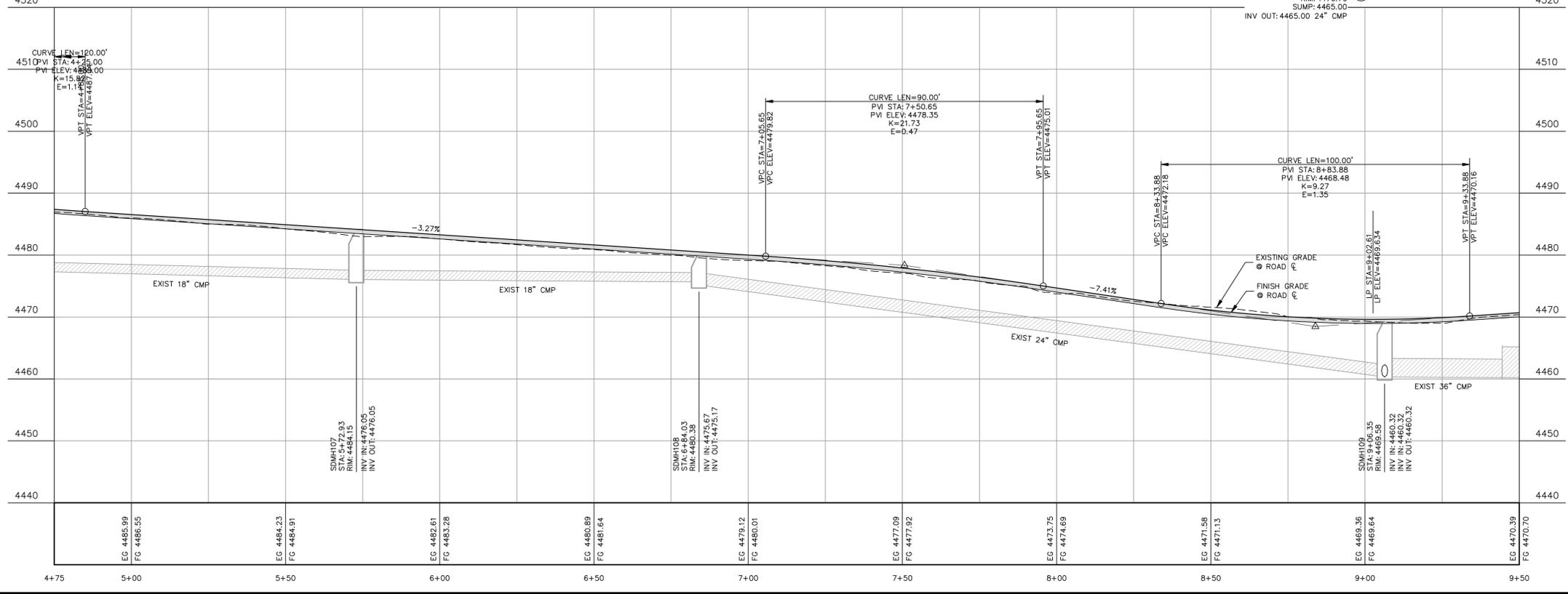

- ### DEMOLITION NOTES
- CLEAR AND GRUB
 - REMOVE EXISTING 2" WATER SERVICE & 4" FIRE SERVICE PER ARIZONA WATER COMPANY REQUIREMENTS.
 - REMOVE VALVE ON FIRE AND USE A BLIND FLANGE CAP ON THE 4" TEE.
 - REMOVE 2" SERVICE SADDLE AND CORP STOP AND USE REPAIR CLAMP OVER EXISTING HOLE.
- ### CONSTRUCTION NOTES
- SUBGRADE PREPARATION
 - CONSTRUCT ASPHALT PAVEMENT & SUBGRADE PER TYPICAL ROADWAY SECTION ON DWG C5
 - CENTERLINE STREET MONUMENTS PER M.A.G. STD. DETAIL 120-1 TYPE B.
 - CONSTRUCT TYPE 'A' VERTICAL CURB & GUTTER PER M.A.G. STD. DETAIL 220
 - CONSTRUCT TYPE 'C' ROLL CURB & GUTTER PER M.A.G. STD. DETAIL 220
 - CONSTRUCT TYPE 'D' ROLL CURB & GUTTER PER M.A.G. STD. DETAIL 220
 - CONSTRUCT CURB TRANSITION PER M.A.G. STD. DETAIL 221
 - CONSTRUCT 5' SIDEWALK PER M.A.G. STD. DETAIL 230
 - CONSTRUCT 3' WALKWAY PER DETAIL ON DWG C5
 - CONSTRUCT CONCRETE DRIVEWAY 4" THICK OVER 4" ABC
 - CONSTRUCT RETAINING WALL PER DETAILS ON C7
 - CONSTRUCT TYPE 'F' CATCH BASIN PER M.A.G. STANDARD DETAIL 535 WITH FLO-GUARD PLUS CURB INLET INSERT.
 - INSTALL 18" DIA CMP (14 GA. HELICAL 2-2/3"x1/2") PER M.A.G. STANDARD DETAIL 510 AND STANDARD 621
 - INSTALL 24" DIA CMP (14 GA. HELICAL 2-2/3"x1/2") PER M.A.G. STANDARD DETAIL 510 AND STANDARD 621
 - CONSTRUCT TYPE 'E' DOUBLE CATCH BASIN PER M.A.G. STANDARD DETAIL 534 WITH FLO-GUARD PLUS CURB INLET INSERT.
 - ADJUST MANHOLE TO GRADE PER M.A.G. STD. DETAIL 270
 - RELOCATE EXISTING APS TRANSFORMER PER UTILITY
 - INSTALL 1" SINGLE WATER SERVICE CONNECTION WITH 1" METER PER AZ WTR CO. STANDARD DETAIL E-9-9-1. ADD 1" FIRE SUPPLY LINE PER DETAIL 'J'/C5
 - INSTALL 2" DOUBLE WATER SERVICE CONNECTION WITH 1" METERS PER AZ WTR CO. STANDARD DETAIL E-9-10-2. ADD 1" FIRE SUPPLY LINE PER DETAIL 'H'/C5
 - SAWCUT AND TRENCH REPAIR ASPHALT PER M.A.G. STANDARD DETAIL 200-1 TYPE 'B'
 - CONSTRUCT SIDEWALK RAMP PER DETAILS ON C6.
 - INSTALL 6" PVC SEWER SERVICE
 - INSTALL SEWER CLEANOUT
 - CONNECT TO EXISTING SEWER STUB

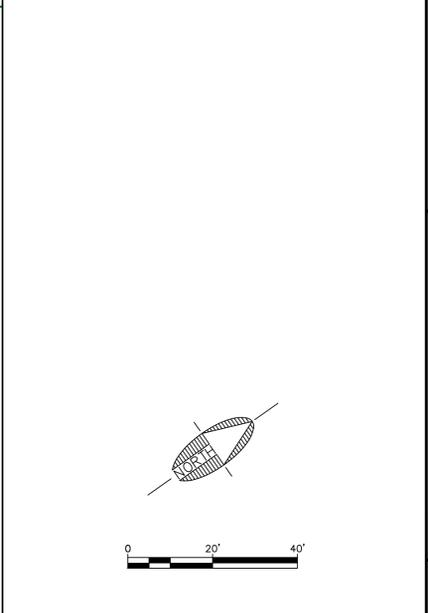

GENERAL NOTES:
ALL STATIONING TO BE SET ALONG THE CENTERLINE OF STREETS, AND WILL BE USED TO DETERMINE THE LOCATION OF FIRE HYDRANTS, CULVERTS, ETC.

THE INFORMATION ON THESE CONSTRUCTION PLANS CONCERNING THE TYPE, SIZE & LOCATION OF UTILITIES HAS BEEN BASED ON THE BEST INFORMATION AVAILABLE. THE CONTRACTOR SHALL BE RESPONSIBLE FOR DETERMINATION OF EXACT LOCATION OF ALL EXISTING UTILITIES PRIOR TO CONSTRUCTION. IT IS THE CONTRACTORS RESPONSIBILITY TO PROTECT ALL EXISTING UTILITIES, IN PLACE, UNLESS OTHERWISE NOTED OR SPECIFIED.



CITY OF SEDONA
ARIZONA

PARK PLACE

PORTOFINO WAY PLAN & PROFILE

JOB NO: 17186
DATE: AUG 19
SCALE: H=1:20 V=1:10
DRAWN: MWJ
DESIGN: ANB
CHECKED: ANB

221 N. Marling St.
Suite 102
Prescott AZ 86301
928.541.0443
928.541.1075 fax
www.swi-gz.com

SWI
Shephard Wesnitzer, Inc.

NO.	DESCRIPTION	DATE	BY

Call at least two full working days before you begin excavation.

ARIZONA 801
Arizona Blue Stakes, Inc.
808 84-1 or 1-800-514-6111 (782-5348)

DRAWING NO.
C12

SHT NO. OF
12 OF 15

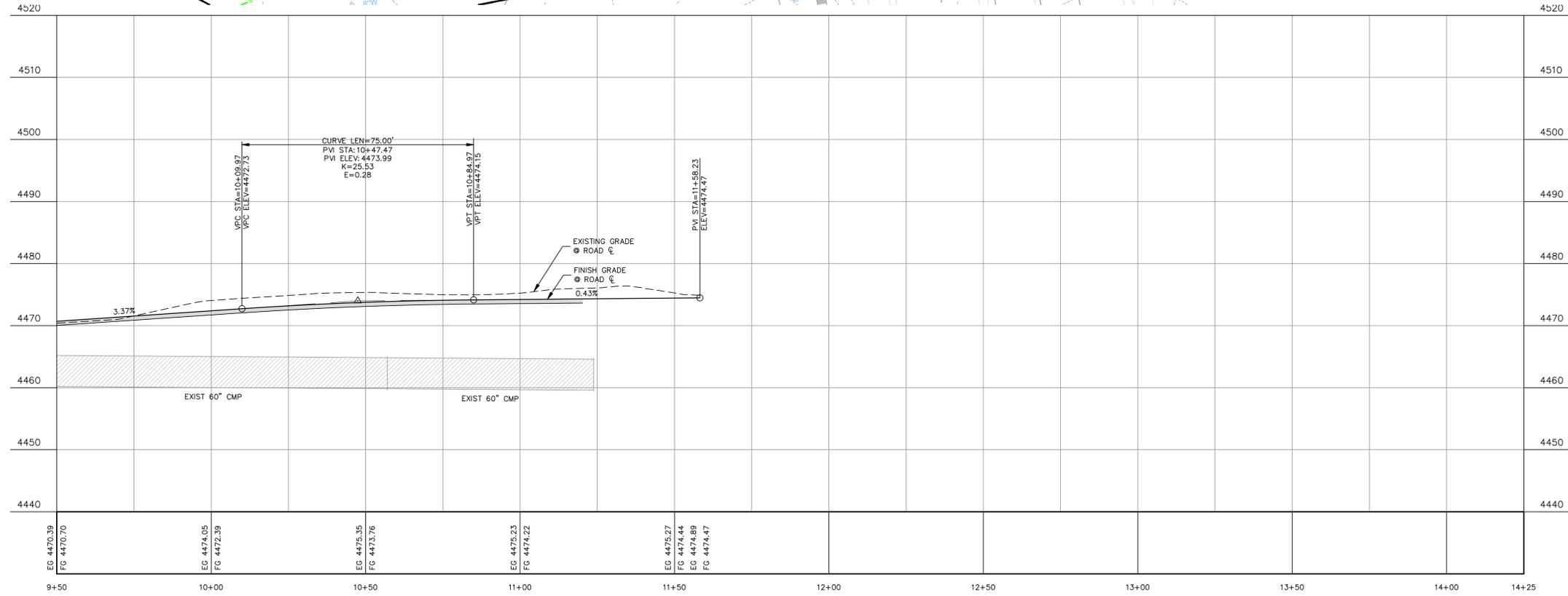
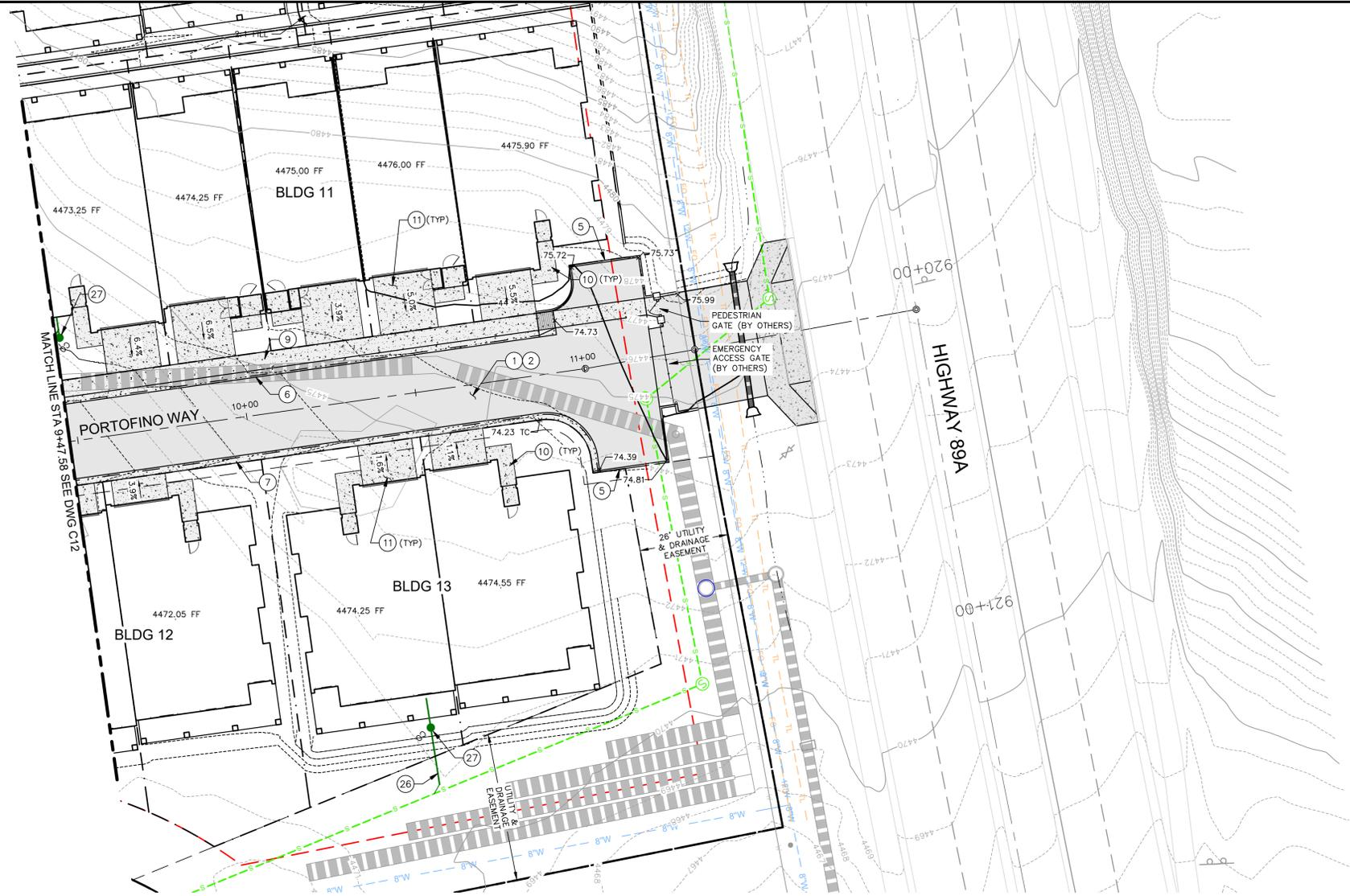

- ### CONSTRUCTION NOTES
- 1 SUBGRADE PREPARATION
 - 2 CONSTRUCT ASPHALT PAVEMENT & SUBGRADE PER TYPICAL ROADWAY SECTION ON DWG C5
 - 5 CONSTRUCT TYPE "A" VERTICAL CURB & GUTTER PER M.A.G. STD. DETAIL 220
 - 6 CONSTRUCT TYPE "C" ROLL CURB & GUTTER PER M.A.G. STD. DETAIL 220
 - 7 CONSTRUCT TYPE "D" ROLL CURB & GUTTER PER M.A.G. STD. DETAIL 220
 - 9 CONSTRUCT 5' SIDEWALK PER M.A.G. STD. DETAIL 230
 - 10 CONSTRUCT 3' WALKWAY PER DETAIL ON DWG C5
 - 11 CONSTRUCT CONCRETE DRIVEWAY 4" THICK OVER 4" ABC
 - 26 INSTALL 6" PVC SEWER SERVICE
 - 27 INSTALL SEWER CLEANOUT

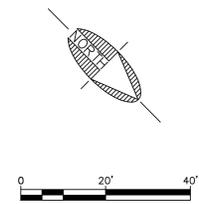

GENERAL NOTES:
 ALL STATIONING TO BE SET ALONG THE CENTERLINE OF STREETS, AND WILL BE USED TO DETERMINE THE LOCATION OF FIRE HYDRANTS, CULVERTS, ETC.
 THE INFORMATION ON THESE CONSTRUCTION PLANS CONCERNING THE TYPE, SIZE & LOCATION OF UTILITIES HAS BEEN BASED ON THE BEST INFORMATION AVAILABLE. THE CONTRACTOR SHALL BE RESPONSIBLE FOR DETERMINATION OF EXACT LOCATION OF ALL EXISTING UTILITIES PRIOR TO CONSTRUCTION. IT IS THE CONTRACTORS RESPONSIBILITY TO PROTECT ALL EXISTING UTILITIES, IN PLACE, UNLESS OTHERWISE NOTED OR SPECIFIED.



CITY OF SEDONA ARIZONA	
PARK PLACE	
JOB NO: 17186	DATE: AUG 19
SCALE: H=1:20 V=1:10	DRAWN: MWJ
DESIGN: AHB	CHECKED: AHB
221 N. Marling St. Suite 102 Prescott, AZ 86301 928.541.0443 928.541.1075 fax www.swi-gz.com	
Shephard Wesnitzer, Inc.	
REVISIONS	BY
NO.	DATE
DESCRIPTION	
DRAWING NO. <h2 style="margin: 0;">C13</h2>	
SHT NO. 13	OF 15

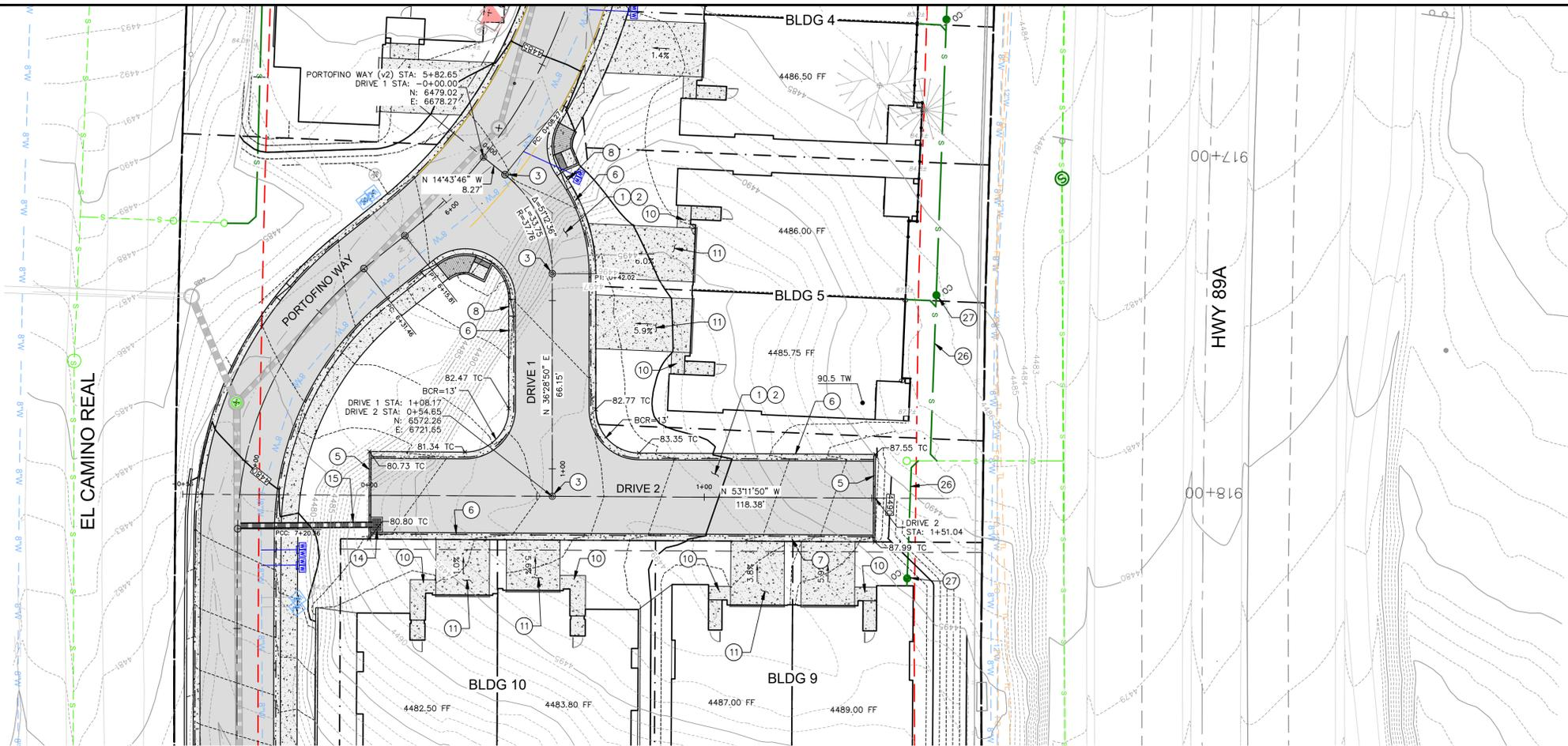

- ### CONSTRUCTION NOTES
- 1 SUBGRADE PREPARATION
 - 2 CONSTRUCT ASPHALT PAVEMENT & SUBGRADE PER TYPICAL ROADWAY SECTION ON DWG C5
 - 3 CENTERLINE STREET MONUMENTS PER M.A.G. STD. DETAIL 120-1 TYPE B.
 - 6 CONSTRUCT TYPE "C" ROLL CURB & GUTTER PER M.A.G. STD. DETAIL 220
 - 7 CONSTRUCT TYPE "D" ROLL CURB & GUTTER PER M.A.G. STD. DETAIL 220
 - 8 CONSTRUCT CURB TRANSITION PER M.A.G. STD. DETAIL 221
 - 10 CONSTRUCT 3" WALKWAY PER DETAIL ON DWG C5
 - 11 CONSTRUCT CONCRETE DRIVEWAY 4" THICK OVER 4" ABC
 - 14 CONSTRUCT TYPE "F" CATCH BASIN PER M.A.G. STANDARD DETAIL 535 WITH FLO-GUARD PLUS CURB INLET INSERT.
 - 15 INSTALL 18" DIA CMP (14 GA. HELICAL 2-2/3"x1/2") PER M.A.G. STANDARD DETAIL 510 AND STANDARD 621
 - 26 INSTALL 6" PVC SEWER SERVICE
 - 27 INSTALL SEWER CLEANOUT

JOB NO:	17186
DATE:	AUG 19
SCALE:	H=1:20 V=1:10
DRAWN:	MWJ
DESIGN:	AHB
CHECKED:	AHB

221 N. Marling St.
Suite 102
Prescott, AZ 86301
928.541.0443
928.541.1075 fax
www.swi-gz.com



NO.	DESCRIPTION	DATE	BY

GENERAL NOTES:
ALL STATIONING TO BE SET ALONG THE CENTERLINE OF STREETS, AND WILL BE USED TO DETERMINE THE LOCATION OF FIRE HYDRANTS, CULVERTS, ETC.

THE INFORMATION ON THESE CONSTRUCTION PLANS CONCERNING THE TYPE, SIZE & LOCATION OF UTILITIES HAS BEEN BASED ON THE BEST INFORMATION AVAILABLE. THE CONTRACTOR SHALL BE RESPONSIBLE FOR DETERMINATION OF EXACT LOCATION OF ALL EXISTING UTILITIES PRIOR TO CONSTRUCTION. IT IS THE CONTRACTOR'S RESPONSIBILITY TO PROTECT ALL EXISTING UTILITIES, IN PLACE, UNLESS OTHERWISE NOTED OR SPECIFIED.

Call at least two full working days before you begin excavation.

ARIZONA 811
Arizona Blue Sticks, Inc. (928-5348)
Dial 8-1-1 or 1-800-514-6111

DRAWING NO. **C14**

SHT NO. 14 OF 15

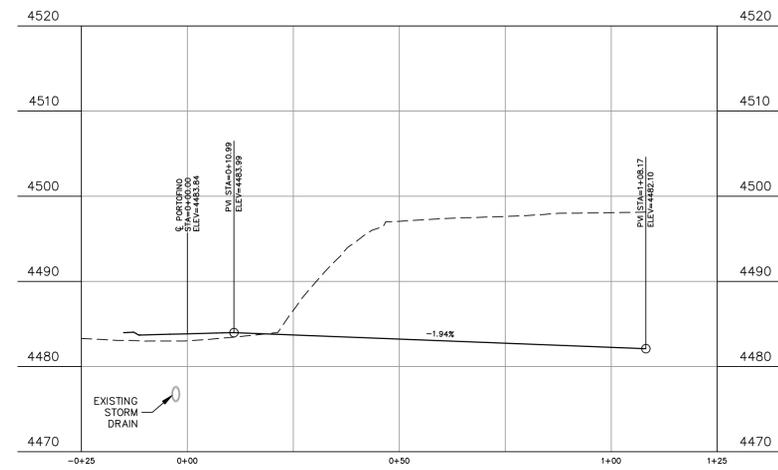

DRIVE 1 PROFILE

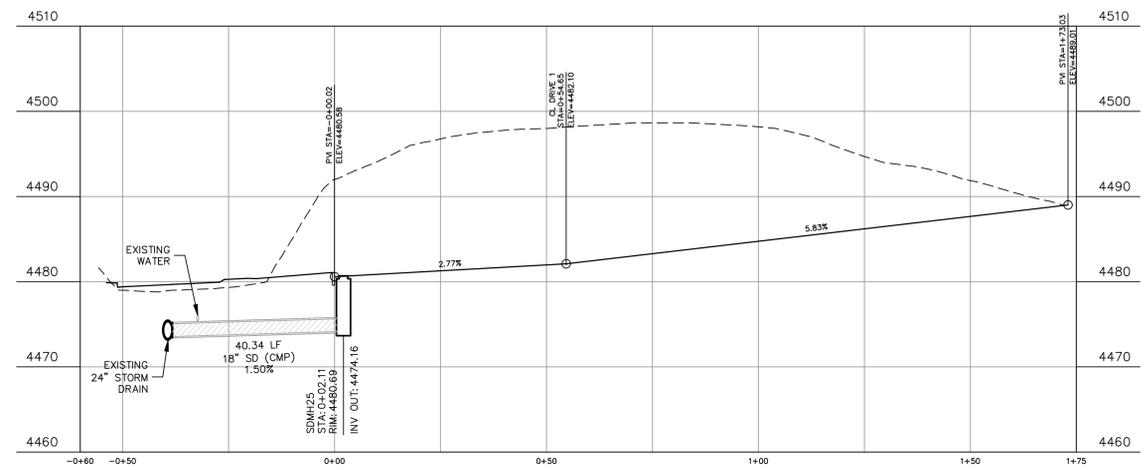

DRIVE 2 PROFILE

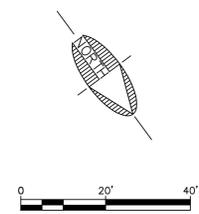

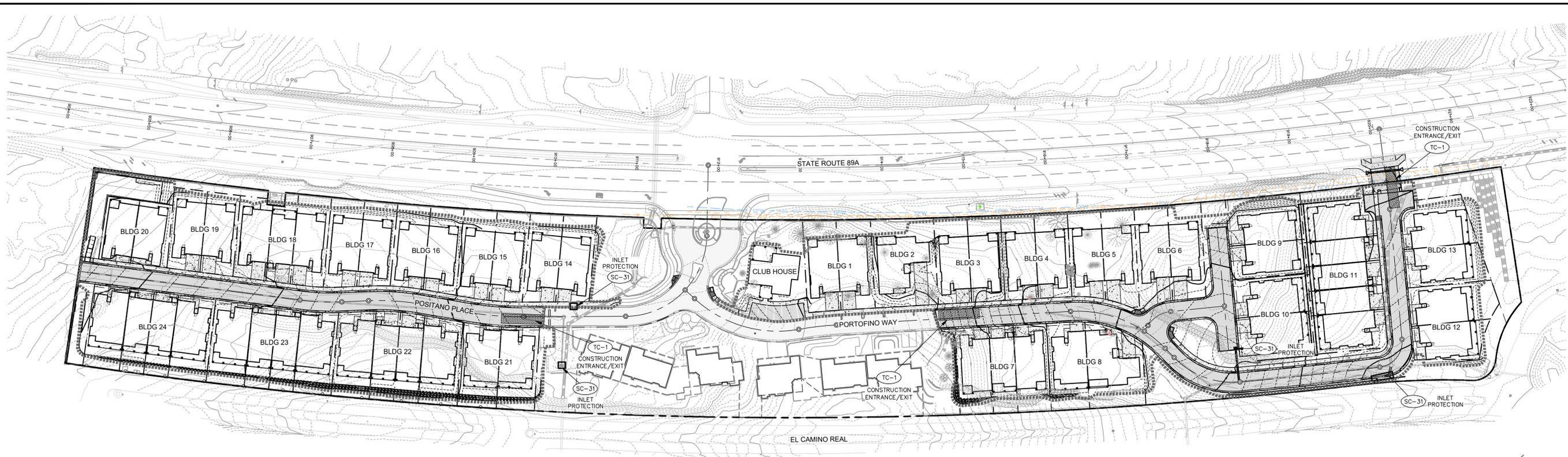

JOB NO:	17186	CITY OF SEDONA
DATE:	AUG 19	ARIZONA
SCALE:	AS SHOWN	
DRAWN:	MJW	
DESIGN:	AHB	
CHECKED:	AHB	

75 Killion Place
 Sedona, AZ 86336
 928.282.1081
 928.282.2058 fax
 www.swiqz.com



NO.	DESCRIPTION	DATE	BY

Call at least two full working days before you begin excavation.
ARIZONA 801
 Arizona Best Stakes, Inc.
 808 84-11 or 1-800-514-6111 (AZ-5148)

DRAWING NO. **SW1**

SHT NO. 15 OF 15

EROSION & SEDIMENT CONTROL STANDARD NOTES

- THE CONTRACTOR MUST NOTIFY BLUE STAKE AT 1-800-STAKE-IT AT LEAST 24 HOURS PRIOR TO THE START OF CONSTRUCTION IN ACCORDANCE WITH APPLICABLE CITY ORDINANCES AND POLICIES.
- THE CONTRACTOR GRANTS THE RIGHT-OF-ENTRY ON TO THIS PROPERTY TO THE DESIGNATED CITY OF SEDONA PERSONNEL FOR THE PURPOSE OF INSPECTING AND MONITORING FOR COMPLIANCE WITH EROSION AND SEDIMENT CONTROL LAW AND THE DESIGN AND CONSTRUCTION STANDARDS MANUAL.
- ALL EROSION CONTROL MEASURES SHOWN ON THE APPROVED PLAN MUST BE IN PLACE, INSPECTED AND APPROVED BY THE CITY OF SEDONA PRIOR TO CLEARING, STRIPPING OF TOPSOIL OR GRADING.
- THE CONTRACTOR'S REPRESENTATIVE IS RESPONSIBLE FOR THE INSTALLATION OF ANY ADDITIONAL EROSION CONTROL MEASURES NECESSARY TO PREVENT EROSION AND SEDIMENTATION.
- ALL DISTURBED AREAS ARE TO DRAIN TO APPROVED SEDIMENT CONTROL MEASURES AT ALL TIMES DURING LAND DISTURBING ACTIVITIES AND DURING SITE DEVELOPMENT UNTIL COMPLETE AND ADEQUATE STABILIZATION IS ACHIEVED.
- WATER MUST BE PUMPED INTO AN APPROVED FILTERING DEVICE DURING DEWATERING OPERATIONS.
- THE CONTRACTOR'S REPRESENTATIVE SHALL INSPECT AND DOCUMENT ALL EROSION AND SEDIMENT CONTROL MEASURES DAILY AND AFTER EACH SIGNIFICANT RAINFALL. THE FOLLOWING ITEMS WILL BE CHECKED IN PARTICULAR:
 - SEDIMENT BASINS WILL BE CHECKED REGULARLY FOR SEDIMENT CLEANOUT. SEDIMENT SHALL BE REMOVED AND THE BASIN RESTORED TO ITS ORIGINAL DIMENSIONS WHEN THE SEDIMENT HAS ACCUMULATED TO ONE HALF THE DESIGN VOLUME OF THE WET STORAGE. SEDIMENT REMOVED FROM THE BASIN SHALL BE DEPOSITED IN A SUITABLE AREA AND IN A MANNER THAT IT WILL NOT ERODE AND CAUSE SEDIMENTATION PROBLEMS.
 - GRAVEL OUTLETS WILL BE CHECKED REGULARLY FOR SEDIMENT BUILDUP WHICH WILL PREVENT DRAINAGE. IF THE GRAVEL IS CLOGGED BY SEDIMENT, IT SHALL BE REMOVED AND CLEANED OR REPLACED.
- INSPECTION FORMS SHALL BE COMPLETED BY THE CONTRACTOR'S INSPECTOR WITH THE MINIMUM FOLLOWING INFORMATION: INSPECTION DATE, TITLE AND QUALIFICATIONS OF EACH INSPECTOR, WEATHER INFORMATION FOR PERIOD SINCE LAST INSPECTION, LOCATION OF DISCHARGE OF SEDIMENT OR OTHER POLLUTANTS, LIST OF BMPs THAT NEED TO BE MAINTAINED OR ARE INADEQUATE, LIST ADDITIONAL NEEDED BMPs, CORRECTIVE ACTION REQUIRED, SOURCES OF ALL NON-STORMWATER AND CONTROL MEASURES, DATES WHEN MAJOR GRADING ACTIONS OCCURRED, POLLUTANT DISCHARGE STATUS OF STORAGE AREAS, AND DATES WHEN CONSTRUCTION ACTIVITIES CEASED.
- CONTRACTOR IS RESPONSIBLE FOR MAINTAINING INSPECTION RECORDS FOR AT LEAST THREE (3) YEARS FOLLOWING THE COMPLETION OF PROJECT. A COPY OF THE APPROVED EROSION AND SEDIMENT CONTROL PLAN SHALL BE KEPT ON SITE AT ALL TIMES AND SHALL BE AMENDED AS NECESSARY TO REFLECT CURRENT SWPPP BMP'S
- THE SWPPP SHALL BE MODIFIED BY THE CONTRACTOR WITHIN 7 CALENDAR DAYS FOLLOWING AN INSPECTION THAT DISCOVERS AN INADEQUATE BMP. BMPs SHALL BE MODIFIED OR ADDED AS SOON AS PRACTICABLE AFTER THE BMP HAS BEEN DETERMINED INADEQUATE.
- PERMANENT SOIL STABILIZATION SHALL BE APPLIED TO DENUDED AREAS WITHIN SEVEN (7) DAYS AFTER FINAL GRADE IS REACHED AND ALL WORK COMPLETED ON ANY PORTION OF THE SITE. TEMPORARY SOIL STABILIZATION SHALL BE APPLIED WITHIN SEVEN (7) DAYS TO DENUDED AREAS THAT MAY NOT BE AT FINAL GRADE BUT WILL REMAIN UNDISTURBED FOR LONGER THAN FOURTEEN (14) DAYS. ROADS AND PARKING AREAS SHALL BE STABILIZED AS SOON AS PRECIPITATION OCCURS OR IRRIGATION IS AVAILABLE.
- ALL TEMPORARY EROSION AND SEDIMENT CONTROL MEASURES WILL BE REMOVED UPON COMPLETION OF EACH PHASE.
- WHEN SEDIMENT APPEARS ON A PAVED ROAD SURFACE, THE ROAD WILL BE CLEANED THOROUGHLY AT THE END OF EACH DAY. SEDIMENT WILL BE REMOVED FROM THE ROADS BY SHOVELING OR SWEEPING AND TRANSPORTED TO A SEDIMENT CONTROL DISPOSAL AREA. STREET WASHING WILL BE ALLOWED ONLY AFTER SEDIMENT IS REMOVED IN THIS MANNER.
- AREAS WHICH ARE NOT TO BE DISTURBED WILL BE CLEARLY MARKED BY FLAGS, SIGNS, ETC.
- A COPY OF THE PROJECT'S STORM WATER POLLUTION PREVENTION PLAN (SWPPP) SHALL BE MAINTAINED AT THE CONSTRUCTION SITE AND SHALL ALWAYS BE AVAILABLE FOR REVIEW.
- CONTRACTOR SHALL BE RESPONSIBLE FOR UPDATING THE SWPPP THROUGHOUT CONSTRUCTION AND INDICATE ANY AND ALL REVISIONS / UPDATES ON THIS PLAN.
- APPROVAL OF PLANS DOES NOT RELIEVE THE OPERATOR FROM CORRECTING ERRORS OR OMISSIONS DISCOVERED DURING CONSTRUCTION. CONFORMANCE WITH THE REQUIREMENTS OF THIS PLAN SHALL IN NO WAY RELIEVE THE

OPERATOR FROM HIS RESPONSIBILITIES TO THE SITE AND ADJACENT PROPERTIES. TEMPORARY EROSION CONTROL SHALL CONSIST OF, BUT NOT BE LIMITED TO, CONSTRUCTING SUCH FACILITIES AND TAKING SUCH MEASURES AS ARE NECESSARY TO PREVENT, CONTROL, AND ABATE WATER, MUD AND EROSION DAMAGE TO PUBLIC AND PRIVATE PROPERTY AS A RESULT OF THE CONSTRUCTION OF THIS PROPERTY.

- CONTRACTOR SHALL IMMEDIATELY RESTORE ANY DAMAGED EROSION CONTROL MEASURE WITHIN THE PROJECT BOUNDARY.
 - FLOOD PLAIN LIMITS SHALL BE CLEARLY MARKED IN THE FIELD BY FLAGS, SIGNS, ETC.
 - TREE SAVE AREAS SHALL BE CLEARLY MARKED IN THE FIELD BY ORANGE SAFETY FENCE.
 - THE SWPPP SHALL BE MODIFIED BY THE CONTRACTOR WITHIN 7 BUSINESS DAYS FOLLOWING ANY CHANGE IN DESIGN, CONSTRUCTION OPERATION, OR MAINTENANCE THAT HAS A SIGNIFICANT EFFECT ON DISCHARGE OR NOT PREVIOUSLY ADDRESSED IN THE SWPPP.
 - THE SWPPP SHALL BE MODIFIED BY THE CONTRACTOR WITHIN 7 BUSINESS DAYS IF IT IS DETERMINED THAT DISCHARGE IS CAUSING OR CONTRIBUTING TO WATER QUALITY EXCEEDENCES OR THE SWPPP IS INEFFECTIVE.
- EROSION CONTROL MEASURES**
 ALL STRUCTURAL EROSION AND SEDIMENT CONTROL PRACTICES SHALL BE CONSTRUCTED AND MAINTAINED ACCORDING TO MINIMUM STANDARDS AND SPECIFICATIONS ESTABLISHED HEREIN.

STRUCTURAL PRACTICES

- SANDBAG DIKES: SANDBAG DIKES WILL BE INSTALLED IN BOTTOM OF WASH UPSTREAM AND DOWNSTREAM OF CONSTRUCTION AREAS AS INDICATED ON THE PLANS FOR EACH PHASE OF THE PROJECT.

MANAGEMENT STRATEGIES

- CONSTRUCTION WILL BE SEQUENCED SO THAT GRADING OPERATIONS CAN BEGIN AND END AS QUICKLY AS POSSIBLE.
- THE JOB SUPERINTENDENT SHALL BE RESPONSIBLE FOR THE INSTALLATION AND MAINTENANCE OF ALL EROSION AND SEDIMENT CONTROL PRACTICES.
- AFTER ACHIEVING PERMANENT STABILIZATION, THE TEMPORARY EROSION & SILTATION CONTROLS WILL BE CLEANED UP AND REMOVED FROM THE SITE.

GENERAL NOTES

- ALL CONSTRUCTION SHALL CONFORM TO CITY OF SEDONA STANDARDS, MAG STANDARDS, AZDES STANDARDS AND SPECIFICATIONS, AND GENERALLY ACCEPTED CONSTRUCTION PRACTICE.
- THESE PLANS REPRESENT A REASONABLE EFFORT TO IMPLEMENT THE MOST CURRENT AND BEST MANAGEMENT PRACTICES (BMPs) IN MITIGATING STORM WATER POLLUTION DURING CONSTRUCTION. THE EFFECTIVENESS OF THE MITIGATION MEASURES DEPICTED IN THESE PLANS DEPEND IN PART ON PROPER INSTALLATION, IMPLEMENTATION, MAINTENANCE AND REPAIR OF THE DEVICES SELECTED.

GENERAL NOTES FOR SWPPP

- A STANDBY CREW FOR EMERGENCY WORK SHALL BE AVAILABLE AT ALL TIMES DURING THE RAINY SEASON. NECESSARY MATERIALS SHALL BE AVAILABLE ON SITE AND STOCKPILED AT CONVENIENT LOCATIONS TO FACILITATE RAPID CONSTRUCTION OF TEMPORARY DEVICES OR TO REPAIR ANY DAMAGED EROSION CONTROL MEASURES, ESPECIALLY WHEN RAIN IS IMMINENT.
- ALL PROTECTIVE DEVICES SHOWN SHALL BE IN PLACE AT THE END OF EACH DAY.
- AFTER A RAIN STORM, ALL SILT AND DEBRIS SHALL BE REMOVED FROM SANDBAG DIKES.
- PROTECT ALL STORM DRAINAGE STRUCTURES FROM SEDIMENT CLOGGING BY PROVIDING INLET PROTECTION AT ALL OPENINGS.

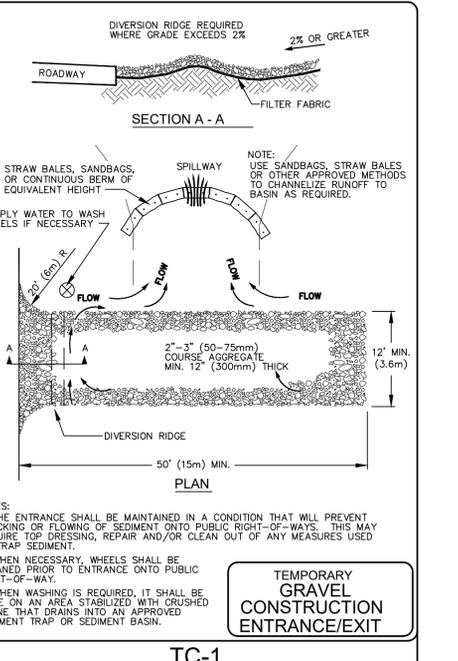
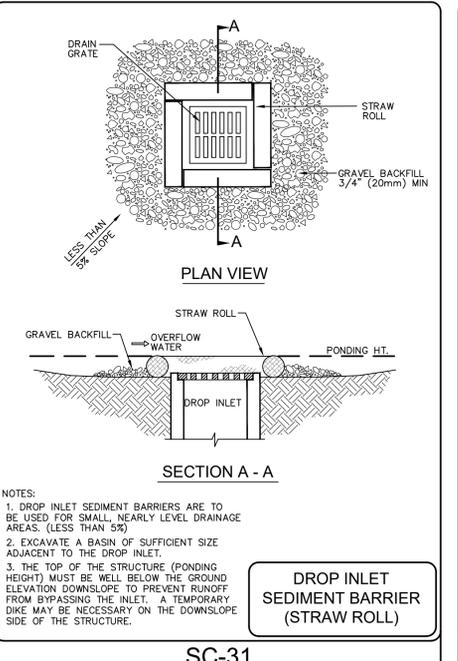
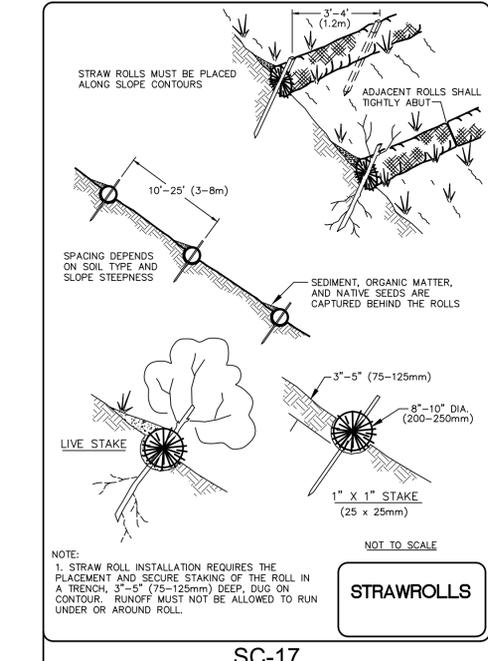

LEGEND

- DISTURBANCE AREA
- RIP RAP
- INLET PROTECTION
- DRAINAGE FLOW
- SC-## BMP REFERENCE (SEE DWG SW2)

