



City of Sedona Public Works Department

102 Roadrunner Drive Sedona, AZ 86336

(928) 204-7111 • Fax: (928) 282-5348

To Whom It May Concern:

The City of Sedona, Arizona is issuing **Addendum #2** to the plans and specifications as originally issued at the time of solicitation for bids for the **Thunder Mountain/Sanborn Roadway & SUP Improvements Project**. For any bid to be considered responsible and responsive, receipt of this addendum must be acknowledged.

As specified in the Instructions to Bidders, this Addendum, upon issuance, has become a part of the Contract Documents.

This Addendum contains 95 pages including this page, 0 changed bid sheets, 0 plan sheets, and 0 additional Technical Specification. Any changed bid sheets shall be used in lieu of the originally issued bid sheets in order to submit a responsive bid.

This Addendum clarifies the following:

1. N/A

This Addendum changes the following:

1. N/A

This Addendum adds the following:

1. The City is providing the Arizona Water Company's General Construction Notes, Specifications, and Details which shall be referred to and followed when performing work on their facilities. If waterline work other than items that are already covered in the plans is needed (plan covered items such as: fire hydrant relocation, adjusting water meter boxes to grade, adjusting water valve boxes to grade, etc.), the Arizona Water Company will arrange for the extra work to be completed through a separate contract.

ACKNOWLEDGEMENT

I have received Addendum #2 for the Thunder Mountain/Sanborn Roadway & SUP Improvements Project as described above, and acknowledge it as part of the Contract Documents for the project.

Signature

Date

Print Business Name

Addendum #2 issued by J. Andy Dickey, PE, Director of Public Works/City Engineer, City of Sedona.



J. Andy Dickey, PE
Director of Public Works/City Engineer

8/4/2020
Date

CONSTRUCTION NOTES:

1. CONNECT M.J. FITTINGS TO M.J. FITTINGS USING FOSTER ADAPTERS.
2. ALL MATERIALS & PIPE REMOVED, MUST BE DISPOSED BY THE CONTRACTOR.
3. ASPHALT REPLACEMENT PER LOCAL PERMIT REQUIREMENTS
4. ALL NEW RESTRAINED PIPE MUST BE U.S. PIPE TR FLEX, AMERICAN FLEX RING OR M.J. DUCTILE IRON PIPE WITH MEGALUG SERIES 1100, STAR GRIP SERIES 3000 OR TUF GRIP SERIES 1000 JOINT RESTRAINTS.
5. USE MEGALUG SERIES 1100, STAR GRIP SERIES 3000 OR TUF GRIP SERIES 1000 JOINT RESTRAINTS AT ALL M.J. FITTING CONNECTIONS..
6. INTERRUPTION OF WATER SERVICE FOR TIE-INS CANNOT EXCEED 4 HOURS IN DURATION FROM TIME OF SHUTDOWN TO COMPLETION OF FLUSHING.
7. COMPANY DOES NOT GUARANTEE EXISTING VALVES WILL PROVIDE A DRY SHUTDOWN.
8. ANY ADDITIONAL FITTINGS REQUIRED FOR TIE-INS BUT NOT SHOWN ON PLANS FOR PROPER ALIGNMENT SHALL BE CONSIDERED INCIDENTAL AND INCLUDED IN THE PIPE PRICE.
9. PROTECT ALL UTILITY CROSSINGS IN PLACE UNLESS OTHERWISE NOTED ON PLANS.
10. TRAFFIC CONTROL PER RIGHT-OF-WAY PERMIT REQUIREMENTS.
11. CONTRACTOR MUST USE NO. 1 METER BOXES WHEN INSTALLING A NEW SERVICE CONNECTION AT THE SAME LOCATION OF AN EX. SERVICE.
12. CONTRACTOR MUST MAINTAIN MIN. 3-FEET HORIZONTAL SEPARATION FROM OUTSIDE OF WATER MAIN TRENCH TO EX. POWER POLES AND PROVIDE BRACING FOR EX. POWER POLES IF NECESSARY DURING CONSTRUCTION.
13. CONTRACTOR MUST PLUG ENDS OF ABANDONED IN PLACE WATER MAINS WITH CLASS 'C' CONCRETE MIN. 24-INCHES INTO PIPE.
14. PASSING COMPACTION TEST RESULTS ARE REQUIRED PRIOR TO PAVEMENT REPLACEMENT.
15. CONTRACTOR MUST PAY THE COST OF ALL WATER PROVIDED BY AWC_o. TO THE CONTRACTOR FOR CONSTRUCTION AND TESTING OF THE WATER MAINS.

16. CONTRACTOR MUST PROVIDE AND INSTALL NEW CUSTOMER SHUTOFF VALVE AT EACH SERVICE WITH PRIOR CUSTOMER PERMISSION.
17. CONTRACTOR MUST COORDINATE MATERIAL, LOCATION, AND TIMING, OF SERVICE TIE-OVERS WITH CUSTOMER.
18. PROTECT WATER LINE TO BE ABANDONED IN PLACE UNTIL FINAL TIE-INS ARE COMPLETED.



ARIZONA WATER COMPANY

SPECIFICATIONS

GENERAL CONDITIONS OF CONTRACT: E-4-1
FEBRUARY 14, 2017 – 1 YEAR

CONSTRUCTION SPECIFICATIONS: E-8-1
NOVEMBER 30, 2017

STANDARD SPECIFICATION DRAWINGS: E-9-1
2010

ARIZONA WATER COMPANY

GENERAL CONDITIONS OF CONTRACT: E-4-1

DEFINITIONS

- A. Authorization to Bill. The words "Authorization to Bill" means the current copy of the Company's Form E-3-25-1 and the procedures described in Paragraph 39 of these General Conditions of Contract.
- B. Company. The words "Company" or "Arizona Water Company" mean Arizona Water Company, and where applicable, any division of Arizona Water Company, whose principal place of business is located at 3805 North Black Canyon Highway, Phoenix, Arizona 85015-5351 (Post Office Box 29006, Phoenix, Arizona 85038-9006).
- C. Company's Authorized Representative. The words "Company's Authorized Representative" mean any officer of the Company, and any of the Company's Engineers, any Division Manager or Superintendent of the Company and/or such other person(s) designated in writing as the "Company's Authorized Representative" by the President or any Vice President of the Company.
- D. Construction Drawings. The words "Construction Drawings" mean plans prepared by or on behalf of Arizona Water Company.
- E. Contract. The word "Contract" means the written document titled "Contract" or "Proposal/Contract" when such document has been signed by an officer or other authorized representative of both the Contractor and the Company.
- F. Contractor. The word "Contractor" means either an individual or other entity employed to do the work as shown on the Construction Drawings and as specified herein.
- G. Inspector. The word "Inspector" means the Company's Authorized Representative or a person designated in writing by the Company's Authorized Representative.
- H. Invitation to Bid. The words "Invitation to Bid" means the current copy of Arizona Water Company's Form E-3-11-4 Request for Proposal/Contract or Form E-3-12-2 Invitation to Bid.

GENERAL CONDITIONS OF CONTRACT

1. GENERAL

These General Conditions of Contract govern all works of installation and construction unless deviations are provided for on the Construction Drawings or in the Contract.

2. BONDS

The Contractor shall, upon request by the Company, furnish a performance bond and a material payment bond in the amount of 100% of the Contract price, in a form and from a surety acceptable to the Company.

3. LABOR AND/OR MATERIAL RELEASES

The Contractor shall supply labor and/or material releases satisfactory to the Company when requested to do so. Forms will be provided by the Company.

4. LICENSE

The Contractor shall have, as may be required by law, a valid license applicable to the work to be performed.

5. INSURANCE

The Contractor shall maintain in full force and effect insurance at no less than the following minimum amounts:

<i>WORKER'S COMPENSATION</i>	In accordance with requirements of the laws of the State of Arizona.
<i>EMPLOYERS' LIABILITY</i>	Each accident \$1,000,000/ \$1,000,000 each employee/ \$1,000,000 policy limit.
<i>COMMERCIAL GENERAL LIABILITY</i> (Including contractual liability covering death, bodily injury and property damage)	Combined single limit of not less than \$1,000,000 per occurrence. \$2,000,000 General Aggregate
<i>CONTRACTORS POLLUTION LIABILITY</i>	\$2,000,000 per occurrence
<i>AUTOMOTIVE LIABILITY</i> (Including owned, non-owned and hired vehicles)	Combined single limit of not less than \$1,000,000 per occurrence.
<i>PRODUCTS – COMPLETED OPERATIONS</i>	\$2,000,000 General Aggregate

*SUBCONTRACTOR'S PUBLIC LIABILITY
AND PROPERTY DAMAGE INSURANCE
AND VEHICLE LIABILITY INSURANCE*

Contractor shall either require each of its subcontractors to procure and to maintain Subcontractor's Public Liability and Property Damage Insurance and Vehicle Liability Insurance of the type and in the amounts specified in this Section 5 or insure the activities of its subcontractors in Contractor's own policy, in like amounts.

*COMMERCIAL EXCESS LIABILITY
COVERAGE*

\$5,000,000 per occurrence

Such insurance shall name the Company, its officers, agents, and employees as additional insured and be primary for all purposes.

The Company will at all times have the right to require that all of such insurance be placed with insurance companies that are satisfactory to it. The Contractor shall file with the Company a certificate evidencing that each policy of insurance for the above coverages in the minimum amounts specified has been purchased and is in good standing.

Such certificate shall provide that notice be given to the Company at least thirty (30) days prior to cancellation or material change in the form of such policies or any of them. Such certificates shall be kept on file by the Company and the Company must have current certificates on file, or a certificate must accompany any bid proposal, before that proposal will be accepted by the Company.

6. CONTRACTOR UNDERSTANDS WORK AND WORKING CONDITIONS

By executing a Contract with the Company, the Contractor warrants that it has, by careful examination, satisfied itself as to the nature and location of the work, including soil conditions, the character, quality and quantity of the materials to be encountered, the character of the equipment and facilities needed preliminary to and during prosecution of the work, the general and local conditions, and all other matters which can in any way be expected to affect its work under the Contract. Verbal agreements or conversations with any officer, agent or employee of the Company, either before or after the execution of the Contract, are not binding upon the Company and shall not affect or modify any of the terms or obligations herein contained.

7. SPECIFICATIONS AND DRAWINGS

The Contractor shall keep on the job a complete copy of all drawings and specifications furnished by the Company which are applicable to the Contract with the Company. Anything mentioned in the specifications and not shown on the drawings or shown on the drawings and not mentioned in the specifications shall be of like effect as if shown or mentioned in both. In case of a discrepancy between the figures, drawings or specifications and physical conditions of the job, the matter shall be immediately submitted to the Company's Authorized Representative for decision as to adjustments, if any, because of the discrepancy; without a decision from the Company's Authorized Representative no discrepancy shall be adjusted by the Contractor, save only at its own

risk and expense. Any deviation from the specifications must be approved in writing by the Company's Authorized Representative.

8. PROPERTY PROTECTION

Trees, fences, poles, underground structures and all other property shall be protected unless their removal is authorized on the Construction Drawings. Any property damaged shall be restored by the Contractor, at its expense, to the owner's satisfaction.

9. SPECIAL PERMITS, LICENSES AND INSURANCE

The Company shall obtain all permits for railroad, county, state, city and irrigation district rights-of-way as well as Forest Service, State Land Department and Bureau of Land Management permits. (Pipeline Contractors)

Whenever blasting is required, the Contractor shall obtain all permits, licenses and insurance required at its expense. (All Contractors)

The Contractor will be required to obtain, and shall certify in writing to the Company that it has obtained, all additional permits required to perform the work including, but not limited to, a National Pollution Discharge Elimination System Permit and/or an Aquifer Protection Permit as those permits relate to disposal of drilling, development and test waters and/or any other discharge or similar activity. (Well Drilling Contractors)

10. SURVEYS

The Company shall be responsible, or arrange, for all surveys required for the work covered in the Contract, unless otherwise specified.

11. BENCH MARKS, PROPERTY STAKES AND SURVEY STAKES

Bench marks, property stakes and survey stakes shall be preserved by the Contractor; in case they are destroyed or removed by Contractor or its employees, the Company will replace them at the Contractor's expense, and the Contractor and its sureties shall be liable therefore.

12. TOOLS, EQUIPMENT AND MATERIALS

The Contractor shall furnish all of the necessary tools, equipment, and pipeline materials required for the work. All material furnished by the Contractor shall be of the quality specified by the Company in its Construction Specifications (E-8-1).

13. SUPERINTENDENCE BY CONTRACTOR

The Contractor shall assure adequate superintendence of the work by a competent foreman or superintendent (with full authority to act on behalf of Contractor) satisfactory to the Company, who will be on the job at all times when work is in progress.

14. ORDER AND DISCIPLINE

The Contractor shall at all times enforce strict discipline and good order among its employees.

15. INDEPENDENT CONTRACTOR

The Contractor is an independent contractor and any provisions in the Contract, the specifications, or these General Conditions of Contract and Arizona Water Company's Construction Specifications which may appear to give the Company the right to direct the Contractor as to the details of the doing of any work to be performed by the Contractor, or to exercise a measure of control over said work, shall be deemed to mean and shall mean, that the Contractor shall follow the desires of the Company in the results of the work only and not in the means whereby said work is to be accomplished, and the Contractor shall use its own discretion and shall have complete and authoritative control over the work and as to the details of the doing of the work.

16. PUBLIC SAFETY AND CONVENIENCE

Contractor shall at all times conduct its work so as to ensure the least possible obstruction to traffic and other inconvenience to the general public and the residents and businesses in the vicinity of the work, and to ensure the protection of persons and property.

To protect persons from injury and to avoid property damage, Contractor shall provide and maintain adequate barricades as required during the progress of the work and until it is safe to use the property for its intended purpose. The rules and regulations of the local governmental agencies and specific permit requirements respecting safety provisions shall be observed at all times.

In the case of blasting, the Contractor shall exercise extreme caution to protect the general public and personal and public property from harm or damage.

17. PROPERTY PROTECTION

Trees, fences, poles, and all other property shall be protected unless their removal is authorized by the Company. Any property damaged shall be restored by Contractor, at his expense, to Company's satisfaction.

18. RESPONSIBILITY OF CONTRACTOR

The work shall be under Contractor's responsible care and charge. Contractor shall bear all loss and damage whatsoever and from whatsoever cause, except that caused solely by the act of Company, which may occur on or to the work during the fulfillment of the Contract. If any loss or damage occurs, Contractor shall immediately make good any such loss or damage, and in the event of Contractor refusing or neglecting to do so, Company may, or by the employment of some other person, make good any such loss or damage, and the cost and expense of so doing shall be charged to Contractor.

The mention of any specific responsibility or liability imposed upon Contractor shall not be construed as a limitation or restriction of any general liability or duty imposed upon Contractor by the Contract. The reference to any specific duty or liability being made herein is merely for the purpose of explanation.

Contractor alone shall at all times be responsible for the safety of Contractor, Contractor's employees, and its subcontractors' employees, and for Contractor and its subcontractors' plant and equipment and the method of performing the work.

19. ERRORS AND OMISSIONS

If Contractor, in the course of the work, becomes aware of any errors or omissions in the Contract Documents or in the instructions, or if Contractor becomes aware of any discrepancy between the Contract Documents and the physical conditions of the site of the work, Contractor shall immediately inform Company in writing. Any work done by Contractor after such discovery, until authorized by Company, will be done at Contractor's risk.

20. LAWS, REGULATIONS

Contractor shall give all notices required by law and comply with all laws, ordinances, rules and regulations, including, but not limited to, all applicable federal, state, local and other legally required health and safety standards, orders, rules, regulations or other laws, pertaining to the conduct of the work. Contractor shall be liable for, and shall defend and indemnify Company against and hold it harmless from, all violations of any law, ordinance, rule, regulation, standard, or order in connection with work furnished by or on behalf of Contractor. If Contractor observes that the Contract Documents are at variance with any law, ordinance, rule, regulation, standard, or order it shall promptly notify Company in writing and any necessary changes shall be adjusted as provided in the Contract for changes in the work. Contractor shall not perform any work contrary to such laws ordinances, rules, regulations, standards, or orders.

21. PERMITS, FEES AND INSPECTIONS

Permits and licenses necessary for the prosecution of the work, including, but not limited to, any National Pollution Discharge Elimination Systems (NPDES) Permits required by U.S. Environmental Protection Agency or the Arizona Department of Environmental Quality shall be secured, paid for, and complied with by Contractor.

Contractor shall be responsible for its actions and shall abide by all conditions and/or restrictions set forth in the NPDES Permit and any other permit or license required for this project.

Company shall at all times have access to the work whenever it is in preparation or in progress and Contractor shall provide proper facilities for such access and for all inspections. If the Contract Documents, the General Superintendent's instructions, laws, ordinances or any public authority require any work to be inspected or approved, Contractor shall give timely notice of its readiness for inspection.

Inspection of the work shall not relieve Contractor of any of its obligations even if defective work or unsuitable materials may have been previously overlooked by Company and accepted or estimated for payment. If any work is found not in accordance with the Contract Documents, Contractor, at its sole cost and expense, shall promptly make good such defective work.

22. CONSTRUCTION MARKING

Each job shall be marked and/or barricaded by the Contractor in such a manner that the construction is clearly visible at all times.

23. EXTRA WORK AND/OR MATERIALS

Except as otherwise herein provided, no charge for any extra work and/or material will be allowed unless the same has been ordered in writing by the Company's Authorized Representative, and the price stated in such order.

24. CHANGES

The Company shall have the right to make any changes in the work that it may determine to be necessary. If such changes affect the cost of the work, an equitable adjustment shall be negotiated. Changes shall in no way affect or void the obligations of both parties under the original Contract.

25. INSPECTION

All work and material shall be open at all times to inspection and acceptance or rejection by the Company's Inspector. Any work covered up by the Contractor prior to inspection and acceptance by the Company shall be subject to being uncovered at the expense of the Contractor for inspection by the Company. The Contractor shall give the Company reasonable notice of starting new work and shall provide, without extra charge, reasonable and necessary facilities for inspection, even to the extent of taking out portions of finished work. In case any such finished work removed is found satisfactory, however, the actual direct cost of such removal and replacement, plus 15% of such cost, will be paid by the Company; in addition, if completion of the work has been delayed thereby, the Contractor shall be granted a suitable extension of time on account of the additional work involved.

26. DEFECTIVE WORK OR MATERIAL

The Contractor shall remove, at its own expense, any work or material found defective by the Company's Inspector and shall rebuild and replace the same without extra charge; in default thereof, the same may be done by the Company at the Contractor's expense.

27. ASSIGNMENT

Neither party to the Contract may assign the Contract or sublet it in whole or in part without the written consent of the other, nor shall the Contractor assign any monies due or which may become due hereunder without the previous written consent of the Company, nor shall such consent release the Contractor from any of its obligations and liabilities under the Contract.

28. RIGHTS OF VARIOUS INTERESTS

Whenever work that is being done for the Company other than by the Contractor is contiguous to work being done by the Contractor, the respective rights of the various interests involved shall be established by the Company to secure the completion of the various portions of the work in general harmony.

29. SUSPENSION OF WORK

The Company's Authorized Representative may at any time and for any reason suspend all or any portion of the work under the Contract. This right to suspend work shall not be construed as denying the Contractor compensation for actual, reasonable and necessary expenses due to suspension to which it may be entitled.

The Company's Authorized Representative may order the Contractor to suspend any work because of certain conditions, such as inclement weather, or because the Contractor is in violation of these General Conditions of Contract or the Construction Specifications. It is understood that compensation for expenses will not be allowed for such suspension when ordered by the Company's Authorized Representative on account of such conditions.

30. PROCEDURE OF WORK

All work under the Contract shall be planned and performed so as to cause a minimum of interference with normal vehicular and pedestrian traffic. At no time shall the Contractor completely obstruct the traffic to any business establishment during normal work hours of that business. It shall be the Contractor's responsibility to maintain facilities for ingress and egress to any business establishment. When crossing any street, not more than one-half of the street may be blocked at one time. All federal, state, county and city laws, rules and regulations relating to this subject are to be obeyed.

The Contractor shall complete any portion or portions of the work in such order of time as the Company may require. The Company shall have the right to take possession of and use any completed or partially completed portions of the work. If such prior possession or use increases the cost of or delays the work, the Contractor will be entitled to extra compensation or extension of time or both, as the Company may determine.

31. DISPUTES

All questions or controversies which arise between the Contractor and the Company, under, or in reference to, the Contract, shall be decided by the Company's Authorized Representative and a representative of the Contractor, and their decision shall be final and conclusive upon both parties.

32. CONNECTION TO EXISTING SYSTEM

Unless approved in writing by the Company's Authorized Representative, no tie-in or hot tap on the existing system shall be made unless the Company's Inspector is present. When the tie-in requires the operation of an existing valve or other control equipment, the conditions of Paragraph(s) 30 and 33 shall be complied with. The Contractor shall notify the Company twenty-four (24) hours prior to tie-in as to the exact time the Contractor plans to make tie-in so that the Company's Inspector will have sufficient time to locate valves and make necessary preliminary arrangements for shut down.

33. PLANNED INTERRUPTION OF WATER SERVICE

No valve or other control on an existing Company water system shall be operated for any purpose by the Contractor without approval of the Company's Inspector. All of the Company's water customers whose service is interrupted by a planned interruption, other than in cases of emergency, shall be notified by the Contractor at least twenty-four (24) hours before the planned interruption and advised of the probable time when the service will be restored.

34. EXISTING UTILITY FACILITIES

The Contractor shall notify all known utilities in the area of the work to be performed under the Contract and shall make arrangements to have their facilities marked in accordance with A.R.S. §40-360.022 ("Blue Stake Law"). The Contractor shall be responsible for

locating and preserving all marked facilities. Any damages to these marked facilities shall be repaired at the expense of the Contractor.

The Company will pay the cost to relocate its or other structures when such structures are found occupying the physical space of the proposed installation. It is understood that the Contractor will be reimbursed for such work only when written authorization from the Company has been obtained in advance of such work.

35. CLEANING UP

The Contractor shall remove from the Company's property and from all public and private property, at its own expense, all temporary structures, rubbish and waste materials resulting from its operations. In the event Contractor fails to do so, the Company may remove same at the expense of the Contractor.

36. WORKING HOURS

Unless stated to the contrary in the Invitation to Bid and/or so stated on the Construction Drawings, or agreed to by the Company during a Pre-Construction Conference, the Contractor shall not be permitted to perform work on Saturdays, Sundays, or Company holidays, or commence work such as tie-ins that cannot be completed during normal working hours.

37. INDEMNITY

- A. The Contractor shall indemnify the Company against, and save and hold it harmless from, any and all liability, claims, demands, loss, actions, causes of action, expense, penalties, fines, assessments, damages and costs of every kind and nature for injury to or death of any and all persons, including, without limitation, employees or representatives of the Company or of the Contractor or of any subcontractor, or any other person or persons, and for damage, destruction or loss, consequential or otherwise, to or of any and all property, real or personal, including, without limitation, property of the Company or of the Contractor or of any subcontractor, or of any other person or persons, and the violation of any law, ordinance, rule, regulation, standard, or order resulting from or in any manner arising out of or in connection with the performance of the work under the Contract, howsoever same may be caused, including, without limitation, the Company's active or passive negligence. The Contractor shall also, upon request by the Company, and at no expense to the Company, defend the Company in any and all suits, concerning such injury to or death of any and all persons, and concerning such damage, destruction or loss, consequential or otherwise, to or of any and all property, real or personal, including, without limitation, suits by employees or representatives of the Company or of the Contractor or of any subcontractor, or any other person or persons, or concerning any court or administrative proceeding concerning the violation of any law, ordinance, rule, regulation, standard, or order.
- B. Contractor shall indemnify the Company against, and save and hold it harmless from, any and all liability, claims, demands, damages, costs, expenses and attorney's fees, suffered or incurred on account of any breach of any obligation, covenant or other provision of this contract, including without limitation, breach of the indemnity provisions of subsection A of this Section 37.
- C. Contractor further agrees to defend, indemnify and hold harmless the Company, its directors, officers, employees, and agents, from and against any and all costs, damages,

claims, expenses, violations, notices of violations, penalties, liens, assessments, and liabilities of every kind and nature, foreseeable or unforeseeable, directly or indirectly, arising from any release, removal, generation, use, storage or disposal on, under, around, or from the well site of any material, substance, or waste, hazardous or non-hazardous, including, without limitation, drilling fluids, mud, cuttings and development and test water howsoever same may be caused, including, without limitation, the Company's active or passive negligence.

38. LIENS

If at any time there shall be evidence of any lien or claim for which the Company might become liable and which is chargeable to the Contractor, the Company shall have the right to retain out of any payment then due or thereafter to become due, an amount sufficient to completely indemnify the Company against such lien or claim. If the Company determines that such lien or claim is valid, the Company may pay and discharge the same, and deduct the amount so paid from any monies which may be or become due and payable to the Contractor.

39. PAYMENT

Upon completion of the installation or construction, the Company will issue an Authorization to Bill using the current copy of the Company's Form E-3-25-1, and thereafter, within thirty (30) days after receipt of proper invoice and fully executed labor and material releases, the Company will pay the amount due the Contractor, less the estimated cost of any paving required of Contractor and, at the option of the Company, 10% of the entire amount of the Contract. Amounts withheld for paving will be paid by the Company within thirty days after acceptance of permanent paving by the Company and applicable governmental agencies. Other remaining amounts, if withheld, will be paid by the Company to the Contractor within thirty days after Contractor completes all work. Partial payments may be authorized by the Company if it so determines but only if partial payments are noted in the Proposal/Contract under Special Conditions. Contractor must mail authorized invoices to:

Arizona Water Company
Attn: Accounts Payable
Post Office Box 29006
Phoenix, AZ 85038-9006

Authorized invoices not addressed as shown above may cause a delay in payment of invoices. Contractor will not charge the Company any late charges. Authorized invoices must be submitted in accordance with the American Institute of Architects standardized method of billing using forms G-702 and G-703, attached hereto, or as otherwise authorized in writing by the Company.

40. COMPANY'S RIGHT TO TERMINATE CONTRACT: DAMAGES DUE TO DELAY

If the Company finds the Contractor to be in material violation of any section of these General Conditions of Contract, Construction Specifications or Standard Specification Drawings or if the Contractor refuses or fails to prosecute the work, or any separable part thereof, with such diligence as will insure its completion within the time specified or any extension thereof, or fails to complete said work within such time, or when any other cause exists to justify such action, the Company may, without prejudice to any other right or

remedy, by written notice to the Contractor, terminate its right to proceed with the work or such part of the work as to which there has been such violation, delay or other cause.

In the event the Contractor's right to proceed is terminated, the Company may take over the work and take possession of, and utilize in completing the work, such materials as may be on the site of the work and necessary therefore and prosecute said work to completion by whatever method it may deem expedient. The Contractor and its sureties shall be liable to the Company for any excess cost caused thereby.

In the event the Contractor's right to proceed with the work is terminated, the Contractor shall not be entitled to receive any further payment until the work is completed or the job is canceled. If the unpaid balance of the Contract price exceeds the expense of finishing the work, including compensation for additional managerial and administrative services, such excess shall be paid to the Contractor. If such expenses exceed such unpaid balance, the Contractor shall pay the difference to the Company.

41. WARRANTY

Contractor warrants to Company for a period of 1 year:

- (i) that all materials and equipment furnished under the Contract will be of good quality and new unless the Contract requires or permits otherwise;
- (ii) that all work will conform to the requirements of the Contract;
- (iii) and that all materials, equipment, and work will be free from defects and will not become defective.

All materials, equipment, and work that do not conform to these requirements will be considered defective. If Company requires, the Contractor will furnish satisfactory evidence as to the kind and quality of materials and equipment. The warranty period begins on the date of the Company's final notice of acceptance. Neither the Company's partial or entire occupancy of the work site nor the Company's partial acceptance of the work will relieve the Contractor of any liability under this warranty. Other warranties may be detailed elsewhere in the Contract with specified coverages or time periods, but these will in no event negate or diminish the warranty detailed in this Section. In addition to the express warranties set forth in this Contract, Company retains all other warranties, express or implied, the law provides.

The Contractor acknowledges it included the cost for all warranty work and obligations in the bid price and that the Contractor will not be entitled to any additional compensation for Contractor's warranty work.

This warranty is in addition to any warranty the manufacturer or supplier of any materials or equipment provides. The Contractor agrees to assign to Company at the time of the Company's final notice of acceptance any and all manufacturer's warranties relating to materials and equipment used in the work and further agrees to perform the work in such manner so as to preserve any and all such manufacturer or supplier warranties. If necessary as a matter of law, the Contractor will retain the right to enforce directly any such manufacturer or supplier warranties.

42. LIQUIDATED DAMAGES FOR NON PERFORMANCE: REQUEST FOR EXTENSION(S) OF TIME

Time is of the essence in the Contract. The time period required for completion of the work will be specified in the Contract. The Contractor agrees that the Company will suffer substantial damages in the event the Contractor fails to complete the work within the agreed upon time period. The Contractor and the Company agree that since it would be impracticable or extremely difficult to precisely fix such damages, a reasonable approximation of such actual damages suffered by the Company shall be a sum equal to 0.5% of the Contract price for each working day beyond the time period for completion of the work specified in the Contract.

Request by the Contractor for extensions of the time period shall be in writing and shall not become effective until approved in writing by the Company's Authorized Representative.

43. PAYMENT FOR REQUIRED TESTING

Whenever testing is required by any governmental agency or by the Company to assure conformance of the Contractor's work with the appropriate standard, it will be paid for as follows:

- a. For testing required under permits obtained by the Company or testing specifically requested by the Company, the cost of the first test will be paid for by the Company. In the event of failure of the first test, the cost of all further testing associated with the failure will be paid by the Contractor.
- b. For testing required under permits obtained by the Contractor, all costs will be paid by the Contractor. Testing of the pipeline for pressure and leakage will be included in the Contract price.

44. CONTRACT DEADLINES AND BONDS REQUIREMENTS

The time limits to be allowed for the completion of any work covered in the Contract shall be established as follows: In the proposal submitted to the Company, in response to the Invitation to Bid, the Contractor shall state the number of calendar days required for completion of the work. The time required will become a part of the Contract. When the Company is ready to proceed with the work, a Commencement Notice will be issued by the Company to the Contractor by mail. The Commencement Notice will allow the time required in the Contract plus ten (10) calendar days and will indicate the final day of the time allowed. The work cannot begin until the Company has received a performance bond and materials payment bond for the Contract price unless the bonds have been waived under the special conditions section of the Contract. The additional ten (10) days is the allowance for time to deliver the Commencement Notice to the Contractor and for the Contractor to return the performance bond and materials payment bond to the Company. Time extensions will be granted if warranted, and only at the time of the delay, thus extending the final day of the time allowed.

If the Company elects not to require a performance bond and a material payment bond for the work, the cost of the bonds will be deducted from the proposed total cost and the Contract will reflect this reduced cost and the bonds requirements will be waived under special conditions of the Contract.

APPLICATION AND CERTIFICATION FOR PAYMENT

AIA DOCUMENT G702 (modified)

TO COMPANY:

Arizona Water Company
 P.O. Box 29006
 Phoenix, AZ 86038-9906

Project Title or Name:
 AWC Responsible Party:
 Project Address or Location:

WORK AUTHORIZATION NO.:
PAYMENT APPLICATION NO.:
PERIOD ENDING:

FROM CONTRACTOR:

CONTRACT DATE:
COMMENCEMENT NOTICE DATE:

CONTRACTOR'S APPLICATION FOR PAYMENT

APPROVED CHANGE ORDER SUMMARY		
NUMBER	DATE APPROVED	DEDUCTIONS
TOTALS		
NET CHANGE BY CHANGE ORDERS		

Application is made for payment, as shown below, in connection with the Proposal/Contract. Continuation Sheet, AIA Document G703 (modified), is attached.

1. ORIGINAL PROPOSAL/CONTRACT SUM _____
2. NET CHANGE BY CHANGE ORDERS _____
3. CONTRACT SUM TO DATE (Line 1 + 2) _____
4. TOTAL COMPLETED TO DATE (Column F on G703 modified) _____
5. RETAINAGE: See column H1 of G703 for retainage %.
 See column H2 of G703 for total retainage _____
6. TOTAL WORK LESS RETAINAGE (Line 4 Less Line 5 Total) _____
7. LESS PREVIOUS CERTIFICATES FOR PAYMENT _____
8. CURRENT PAYMENT DUE _____
9. BALANCE TO FINISH, INCLUDING RETAINAGE _____

The undersigned Contractor certifies that to the best of the Contractor's knowledge, information and belief the Work covered by this Application for Payment has been completed in accordance with the Proposal/Contract, that all amounts have been paid by the Contractor for Work for which previous Certificates for Payment were issued and payments received from the Company, and that current payment shown herein is now due.

CONTRACTOR: _____ **Date:** _____
Signature: _____
Printed Name: _____
Title: _____

ARIZONA WATER COMPANY

CONSTRUCTION SPECIFICATIONS: E-8-1

ARIZONA WATER COMPANY

E-8-1

**CONSTRUCTION SPECIFICATIONS
FOR THE INSTALLATION OF WATER DISTRIBUTION SYSTEMS
DUCTILE IRON**

DEFINITIONS

- A. Company. The words "Company" or "Arizona Water Company" mean Arizona Water Company, and where applicable, any division of Arizona Water Company, whose principal place of business is located at 3805 North Black Canyon Highway, Phoenix, Arizona 85015-5351 (Post Office Box 29006, Phoenix, Arizona 85038-9006).
- B. Company's Authorized Representative. The words "Company's Authorized Representative" mean any officer of the Company, and any of the Company's Engineers, any Division Manager or Superintendent of the Company and/or such other person(s) designated in writing as the "Company's Authorized Representative" by the President or any Vice President of the Company.
- C. Contractor. The word "Contractor" means either an individual or other entity employed to do the work as shown on the Construction Drawings and as specified herein.
- D. Construction Drawings. The words "Construction Drawings" mean plans prepared by or on behalf of Arizona Water Company.
- E. Contract. The word "Contract" means the written document titled "Proposal/Contract" when such document has been signed by an officer or other authorized representative of both the Contractor and the Company.

CONSTRUCTION SPECIFICATIONS FOR THE INSTALLATION OF WATER DISTRIBUTION SYSTEMS DUCTILE IRON

1. GENERAL

All work is to be completed in a safe, workmanlike manner and in accordance with these Construction Specifications; any deviation therefrom must be approved in writing by the Company.

Installations must conform with the requirements of all governmental regulating agencies and the cost of conforming to such regulations must be included in the unit bid prices. Examples of such regulations, without attempting to be inclusive, are:

- a. Special compaction and paving for street crossing.
- b. Shoring when required because of the trench depth.
- c. Closing a trench in those areas where no open trench is allowed overnight.
- d. Barricading and traffic control as required.

2. LOCATION MARKING

Alignment stakes as required in the opinion of the Company shall be furnished by the Company to the Contractor and shall be set by the Company at agreed upon intervals and offsets. Under normal circumstances these will reference the pipeline location five feet (5') into the right-of-way measured from property pins. Grade stakes will be provided only when the Construction Drawings show a pipeline depth other than covered in these Specifications. It is the responsibility of the Contractor to preserve all survey work.

3. TRENCH EXCAVATION

The trench location is to be determined by the Construction Drawings.

FOR 8-INCH OR SMALLER PIPE: The depth of the trench prior to pipe laying shall be such that the finished pipeline shall have between thirty-six inches (36") and forty-two inches (42") of cover unless otherwise specified on the Construction Drawings.

FOR 12-INCH AND LARGER PIPE: The depth of the trench prior to pipe laying shall be such that the finished pipeline shall have between forty-eight inches (48") and sixty inches (60") of cover unless otherwise specified on the Construction Drawings.

The width of the trench at and below the level at the top of the pipe shall be a minimum of twelve inches (12") plus the outside diameter of the pipe barrel and a maximum of twenty-four inches (24") plus the outside diameter of the pipe barrel.

The bottom of the trench shall be accurately graded to provide a uniform bearing for each length of pipe for the full length of the pipe. If the native material on the trench bottom can be reasonably dug by hand, bell holes shall be dug for the joints so that the joints in no way support the pipe. When native materials such as rock are encountered during

trenching that will not provide a uniform support for the pipe, the trench will be over-excavated an additional six inches (6") and suitable bedding material will be placed in the trench.

Bedding material will be placed by hand in four-inch (4") lifts and compacted to ensure uniform compaction and to eliminate any voids under the pipe. When the space between the pipe and trench bottom varies, this must be backfilled and compacted in four-inch (4") lifts to the mid-section of the pipe.

Whenever the trench is over-excavated for whatever reason, the trench bottom will be brought up to the correct depth at the Contractor's expense using either method (a) or (b) as follows:

- a. A.B.C. material shall be used and compacted to a uniform density of not less than 80% of the maximum density as determined by AASHTO T-99 method A and T-191.
- b. Native material 100% of which will pass through a one and one-half inch (1½") screen and at least 20% of which will pass through a number-8 screen shall be used and compacted to a uniform density of not less than 85% of the maximum density as determined by AASHTO T-99 method A and T-191.

4. MATERIALS TO BE PROVIDED BY CONTRACTOR

Unless otherwise specified on the Construction Drawings or in the Contract, the Contractor will supply all of the necessary materials which will become a permanent and integral part of the water distribution system, including concrete blocking, anchors, backfill material, paving material and supplies used during the prosecution of the work. All materials provided by the Contractor to construct the water distribution system must be NSF Standard 61 approved. All potable water pipes and fittings shall have NSF-PW seal. Construction materials used in the water system shall be lead free as defined at AAC R18-5-504 and R18-1-101. The Contractor will provide the following materials:

- a. FIRE HYDRANTS: Mueller Super Centurion 250 Fire Hydrant, meets ANSI/AWWA C502 Standard, Model No. A-423, 5¼" main valve opening, three way, 6" Mechanical Joint Shoe, 1½" pentagon operating nut, color - yellow, drain open, open direction - left, 4' or 4'6" bury depending on application. For pumper and hose nozzle information see below.
 - (1) 1 - 4" Pumper Nozzle, NST and 2 – 2½" Hose Nozzles, NST. (These locations only: Ajo, Casa Grande, Coolidge and San Manuel.)
 - (2) 1 – 4½" Pumper Nozzle, NST and 2 – 2½" Hose Nozzles, NST. (These locations only: Apache Junction, Arizona City, Lakeside, Oracle, Overgaard, Pinewood, Rimrock, Sedona, Sierra Vista, White Tank and Winkelman.)
 - (3) 1 – 4½" Pumper Nozzle, NST and 2 – 2½" Hose Nozzles, NPT (Bisbee only.)

- (4) 1 - 3" Pumper Nozzle GA 6-350 (6 threads per inch, 3.50 pitch diameter) and 2 – 2½" Hose Nozzles, NPT (Miami only.)
- (5) 1 – 3½" Pumper Nozzle GA 6-411 (6 threads per inch, 4.11 pitch diameter) and 2 – 2½" Hose Nozzle, NST (Superior only.)
- b. FITTINGS: Manufactured by Tyler or Union. Crosses, Elbows, Tees, Cap, Reducer, Adapter, Plug, Blind Flange and Tapped Flange; Ductile Iron, Class 350, SSB, Cast Iron Cement Lined.
 - (1) Foster Adaptors for MJ, made by Infact Corporation: Available in size 4" to 16". Part No. 4" = 4FA-BC, 6" = 6FA-BC, 8" = 8FA-BC, 10" = 10FA-BC, 12" = 12FA-BC, 16" = 16FA-BC.
- c. DETECTOR CHECK VALVE: Mueller/ Hersey EDC III, iron body, including 5/8" x ¾" Trim Kit. Trim Kit Part No.: 4" = 282080, 6" = 282082, 8" = 282085, 10" = 282496.
- d. GATE VALVES: Mueller Resilient Wedge Gate Valves, meets AWWA C509 specification, 250 psig, Non-rising stem, Part No. A-2360 sizes 4" through 12" ; Part No. A-2361 sizes 14" through 36", low zinc stems, epoxy coated inside and outside to meet the NSF 61 rating. The bonnet and stuffing box shall have 304 stainless steel bolts/nuts.
- e. TRACER WIRE and WARNING TAPE:
 - 1. TRACER WIRE: Shall be direct bury AWG #14 solid copper wire, Color: Blue.
 - 2. WARNING TAPE: Reef Industries, Standard Terra Tape in 3" widths. Color: Blue and imprinted 'Arizona Water Company'.
- f. AIR RELEASE VALVE: Crispin Model AR10 with 1" NPT inlet and ½" NPT outlet, cast iron body and top flange; with a 5/64" orifice with stainless steel valve sealing faces and BUNA-N rubber.
- g. PRESSURE RELIEF VALVE: Watts 174A, Model M, 2" inlet, 2" outlet, Bronze Body, 30lb. to 150lb. pressure range.
- h. MEGA LUG: Mechanical Joint restraint made of ductile iron conforming to ASTM 536-80, 250 psi made by EBAA Iron, Inc., series 1100 or equal.
- i. METER BOXES:
 - (1) Concrete Box with a steel regular lid, Number 1: Tucson specification.
 - (2) Concrete Box with a steel regular lid, Number 2, 3, and 4: Phoenix specification.
- j. PIPE, COPPER: Type K soft copper in 60 or 100-foot coils, per ASTM B88.

- k. PIPE, DUCTILE IRON: Ductile Iron Pipe, Cement Lined, Push-on, conform to current ANSI/AWWA Specification A21.51/C151, Pressure Class 350 (sizes 4" through 12"), Pressure Class 250 (sizes 14" through 20"), or Pressure Class 200 for 24" through 36" pipe. Vendors:
- (1) Pacific States Cast Iron Pipe Company
 - (2) Griffin Pipe
 - (3) United States Pipe and Foundry Company
 - (4) American Ductile Iron Pipe
 - (5) Clow Pipe (McWane, Inc.)
- l. PIPE, PLASTIC: Plastic pipe, C-900 PVC per ANSI/AWWA C900, Class 235, sizes 4" through 12". NSF61 approved. Furnished in laying lengths of 20'. The barrel shall conform to the outside dimensions of steel pipe (IPS) or cast iron (CI) pipe equivalent and the wall thickness of dimension-ratio (DR) 18. The use of C-900 Plastic Pipe is only allowed in the Coolidge area of the Pinal Valley water system with prior written approval from the Company's Engineering Department.
- m. POLYETHYLENE ENCASEMENT (Polywrap): For all pipeline and related fittings installed, EXCEPT for the Coolidge Division. Minimum 8 Mil. and installed per AWWA C105/A21.5-93 and ASTM A-674-89. Manufactured by the Pacific States Cast Iron Pipe Company. The wrapping tape shall be minimum 10 mil. vinyl tape. No duct tape shall be used.
- n. COUPLING: Mueller, straight three part union, tested to meet ANSI/AWWA C800, H15403, conductive compression.
- Mueller, H15428, straight coupling, conductive compression by male iron pipe, tested to meet ANSI/AWWA C800 specification. Size: 2".
- Mueller, H15451, straight coupling, conductive compression by female iron pipe, tested to meet ANSI/AWWA C800 specification. Size: 2".
- Viking Johnson brand, sold by Mueller: MaxiFit Straight (2"-24"), MaxiFitXtra Straight (4"-8") or MaxiStep Transition, tested to meet AWWA/ANSI C.219-91 specifications – certified to ISO 9001:1994 / Smith – Blair Quantum.
- o. STOP, ANGLE METER, BALL: Mueller, valve, B24258, conductive compression by meter swivel nut, tested to meet ANSI/AWWA C800, size 5/8" x 3/4" x 3/4" for a 3/4" service or size 1" for a 1" service.
- Mueller, valve, B24265, female pipe thread by meter swivel nut, tested to meet ANSI/AWWA C800, size 5/8" x 3/4" x 3/4" for a 3/4" service or size 1" for a 1" service.
- p. STOP, CORP: Mueller, ball valve, B25008, taper thread by conductive compression, tested to meet ANSI/AWWA C800 specification, sizes: 3/4", 1" and 2".
- Mueller, ball valve, B25028, iron pipe thread by conductive compression, tested to meet ANSI/AWWA C800 specification. Sizes 3/4", 1", and 2".

Mueller, 300 Ball Curb Valve, B-25122, taper thread by conductive compression, tested to meet ANSI/AWWA C800 specifications, size: 2". (2" service)

- q. STOP, CURB: Oriseal valve, H10291, iron pipe thread by iron pipe thread, quarter turn check, brass, tested to 300 psi working pressure, tested to meet ANSI/AWWA C800 specification, size: 2".

Mueller, B20283, Mueller 300 ball curb valve, female iron pipe by female iron pipe, quarter turn check, tested to meet ANSI/AWWA C800 specification. Size: 2". (Blow-off E-9-8-1).

- r. TAPPING SADDLE: Smith Blair, Cast Bronze ASTM-B584 85-5-5-5, double strap, iron pipe threads, Models 321 and 323. Washers are silicon bronze, ASTM-B36. Gaskets are grade 60 Buna N, or Mueller bronze double strap service saddle, BR 2 B series, cast bronze, ASTM-B585, 85-5-5-5, or H16084, 200 psig, meets ANSI/AWWA C800.

- s. TAPPING SLEEVE: Mueller H304 Stainless Steel Tapping Sleeve, JCM 432 18-8 Type 304 Stainless Steel Tapping Sleeve, Romac "SST" Type 304 Stainless Steel Tapping Sleeve or CASCADE-style CST-EX stainless steel pressure-rated tapping sleeve.

- t. TAPPING VALVE: Mueller Resilient Wedge tapping valve, Catalog Number T-2360-16, Class 125, sizes 4" through 12"; T-2361-16, Class 125, sizes 14" to 36" all with Type 304 stainless steel fasteners; bypass valves are required on 18" – 36" valves flange by mechanical joint per ANSI/AWWA C111, iron wedge, non-rising stem. Epoxy coated interior/exterior per ANSI/AWWA C550 for NSF 61 compliance. 250 PSI range for valves 4" to 12". 150 PSI range for valves 14" to 36".

- u. U-BRANCH: Mueller, H15364, 1" male iron pipe by ¾" male iron pipe, tested to meet ANSI/AWWA C800 specification. Size: 1" x ¾" x 13½", straight line.

- v. VALVE BOXES: Valve Box with Cover, adjustable, Tyler 562-A or equal, made of cast iron.

- w. VAULTS: Utility Vault Company, Chandler, AZ.

- (1) 4484-WA concrete vault with a 3660 aluminum double torsion door with a recessed padlock hasp, two - 18" x 24" center knockouts.

- (2) 575-WA concrete vault with a 4874 aluminum double torsion door with a recessed padlock hasp, two - 18" x 24" center knock outs and adjustable frame.

- (3) 612-5X-WA concrete vault with a 4874 aluminum double torsion door with a recessed padlock hasp, two - 18" x 24" center knockouts.

- x. VALVE, METER: Mueller, B24265-1, Mueller 300 ball angle meter valve, female iron pipe by meter nut, quarter turn check, lock wing, tested to meet ANSI/AWWA C800 specification. Size: 1".

Mueller, B25170, Mueller 300 ball straight valve, conductive compression by female iron pipe, quarter turn check, lock wing, tested to meet ANSI/AWWA C800 specification. Size: 1".

- y. YOKES, METER: Relocator type copper meter yoke with horizontal inlet and outlet and meter thread ends, B24118, with lock wing Mueller 300 angle ball valve, full port, sizes: 1" x 12", 5/8" x 3/4" x 7", 5/8 x 3/4" x 9".

Mueller, 2" copper meter yoke with horizontal inlet and outlet and female iron pipe threads, B2423-99000, with lock wing Mueller 300 ball angle meter valves on inlet and outlet risers. Raised 1" by-pass with lock wing Mueller 300 ball valve.

The Contractor also will be required to provide the following materials, the cost of which will be included in its unit bid price:

All material and concrete for thrust blocks, other anchors, reinforcing steel; all gravel, crushed stone, A.B.C., earth, sand, or screened material which may be required; all material for bracing and shoring trenches and for construction of forms; all barricades and traffic control equipment; all material for paving replacement and any water used for compaction of backfill.

5. INSTALLATION OF MATERIALS

All materials are to be installed in accordance with manufacturers recommendations unless otherwise directed by these Specifications.

All pipe, fittings and valves shall be laid true to the lines, grades and locations established by the Specifications and the Construction Drawings.

The ends and inside of the pipe shall be thoroughly cleaned and inspected for damage. No damaged materials shall be installed in the water distribution system.

Whenever the work ceases for any reason, all open pipeline ends shall be tightly plugged by the Contractor. Plugs shall be watertight and approved by the company.

Concrete thrust blocks of the sizes required by the plans and specifications are to be provided at all valves, changes in direction or size, or at any other point where an unbalanced thrust due to water pressure would exist. Thrust blocks are to be formed to prevent any concrete from spilling over or into a joint.

Trench curves as shown on the Construction Drawings may be made without fittings when using push on joint pipe up to twelve inches (12") in diameter, if the deflection of the pipe does not exceed five degrees (5°) or nineteen inches (19") per eighteen-foot (18') length of pipe. The minimum radius of such curves will be two hundred five feet (205').

Prior to construction, the appropriate agency(ies) will be notified as required by the permit(s).

It shall be the Contractor's responsibility to uncover all existing water lines being connected to, and to verify the location, depth and size of pipe before any construction begins.

Any construction performed without the knowledge of the duly authorized representative is liable for removal and replacement at the Contractor's expense.

All fire hydrants, frames, covers and valve boxes, etc. shall be adjusted to finished grade prior to the placing of the asphalt concrete surface course by the Contractor (where applicable).

Air release valves shall be installed at water system high points per Standard Detail E-9-8-2.

All water services shall be set a minimum of two feet (2') on the customer's property, preferably within the P.U.E. and not within right-of-way.

Unless otherwise specified on the construction drawings, all water mains shall be installed five feet (5') from the property line inside the right-of-way or easement.

Water valves shall be spaced not more than five hundred feet (500') in commercial districts and not more than eight hundred feet (800') in other districts. Variations may be required for transmission mains or special applications.

Installation of water line casing shall be per Standard Specification E-9-24-1.

Tracer Wire and Warning Tape are to be installed on all mains, tees, crosses, ells and fire hydrant laterals. They will not be installed on service lines. The tracer wire will be installed on the water main 45 degrees from the vertical centerline of the pipe and shall be taped to the fittings directly and on the main every 10 feet using a minimum 10 mil vinyl tape. The tracer wire shall be placed between the valve riser and box with a minimum of 12" of wire inside. The warning tape shall be installed a minimum of two feet below the surface, being measured from final grade, directly over the center of the pipe. Any splices in the tracer wire shall be joined using waterproof connectors. Any splices in the warning tape shall be joined using minimum 10 mil vinyl tape. The tracer wire shall be tested for continuity after backfill and compaction, but before paving. Any detected damages to the wire shall be repaired before paving will be allowed.

6. BACKFILL OF WATER MAIN TRENCHES

Backfill of any excavation shall conform to the requirements of any of the governmental agencies having jurisdiction over the location. If no governmental agency having such jurisdiction specifies backfill or compaction requirements, and no special requirements are shown on the Construction Drawings, the procedure set forth in this section will apply for water line trenches.

The bedding material above the pipe and backfill material shall be compacted to a minimum of 70% compaction within a utility easement and 80% compaction within a

right-of-way as determined by AASHTO T-99 method A and T-191. If water settling is used for compaction, it is the responsibility of the Contractor to prevent the pipe from floating.

The bedding material shall be either native material, 100% of which will pass through a one and one-half inch (1½") screen and at least 20% of which will pass through a number-8 screen, or imported material which conforms to M.A.G. specifications for A.B.C. or type-B select materials. Bedding material shall be used below and around the pipe and a minimum of twelve inches (12") above the pipe. Shade and bedding material to be mechanically compacted prior to remainder of trench back-fill.

The remainder of the trench shall be backfilled with native or imported material which shall be of sound earthen material free from broken concrete, wood, broken pavement, or other unsuitable substances. Except as otherwise specified, backfill may be material containing no pieces larger than six inches (6") in greatest dimension.

Where settlement occurs, additional backfill material shall be placed and compacted and the trench shall be brought to final grade.

7. HYDROSTATIC TESTING OF COMPLETED PIPELINES

Hydrostatic testing of water pipelines will be completed before the new system is connected into the existing water system so that all testing can be done against all new materials.

The completed section of water pipeline to be tested shall be slowly filled with water with care being taken to expel all air from the pipe. If necessary, the pipe will be tapped at high points to vent air.

The Contractor shall provide all equipment and labor necessary to accomplish this testing and the price shall be included in the unit prices. The Contractor shall notify the Company in advance of the testing so that the Company can schedule a duly authorized representative to be at the site during testing. The Contractor, at its own expense, shall make any necessary repairs to the system being tested in order to cause the section being tested to meet the test limits set below. The Contractor may request authorization of the Company to connect the new pipelines to the existing system prior to completion of pressure testing when, in the Company's sole opinion and judgment, conditions warrant such connection.

The Contractor shall assume all responsibility to complete pressure testing to Company's specifications after such connection, including, but not limited to, isolation of the new pipelines from the existing system, if necessary.

Connections prior to completion of pressure testing shall not be made unless prior Company authorization has been obtained, and any extra expenses resulting from such connections shall be the sole responsibility of the Contractor.

Leakage tests will be for a period of two hours at 200 ± 5 psi at the point of lowest elevation; leakage may not exceed 0.1 gallons per hour per one thousand feet (1,000') of pipe per inch of diameter. If dry utilities are not installed, a second pressure test is required.

8. STERILIZATION AND FLUSHING OF COMPLETED WATER PIPELINES

Sterilization and flushing will conform to recommendations of Arizona State Department of Health Services Engineering Bulletin Number 8, latest edition, or any future Arizona Department of Environmental Quality bulletins. Contractor to follow all conditions of any discharge permit.

9. NO OTHER UTILITIES ALLOWED IN OR NEAR WATER PIPELINE TRENCHES

No other utility installations will be permitted in the water pipeline trench or within five feet (5') of the Company's water pipeline when running parallel to the water pipelines.

10. PROTECTION OF WATER MAINS NEAR SEWERS

In order to protect water mains from contamination by sewers, the installation of the water mains must conform to the following requirements:

- a. Horizontal - When water lines and sewers are laid parallel with each other, the horizontal distance between them shall not be less than six feet (6'). Each line shall be laid on undisturbed or bedded material in a separate trench. Where conditions prevent the minimum horizontal separation set forth above, extra protection will be required. Extra protection shall consist of constructing the sewer main with mechanical joint ductile iron pipe or with slip-joint ductile iron pipe if joint restraint is provided, or encasing both the water main and sewer main in concrete. See Detail E-9-30-1 and E-9-30-2.

The Construction Drawings shall indicate the installation requirements. The drawings showing these exceptions shall have been approved by the appropriate state and/or county health department. Refer to the diagram below for clarification.

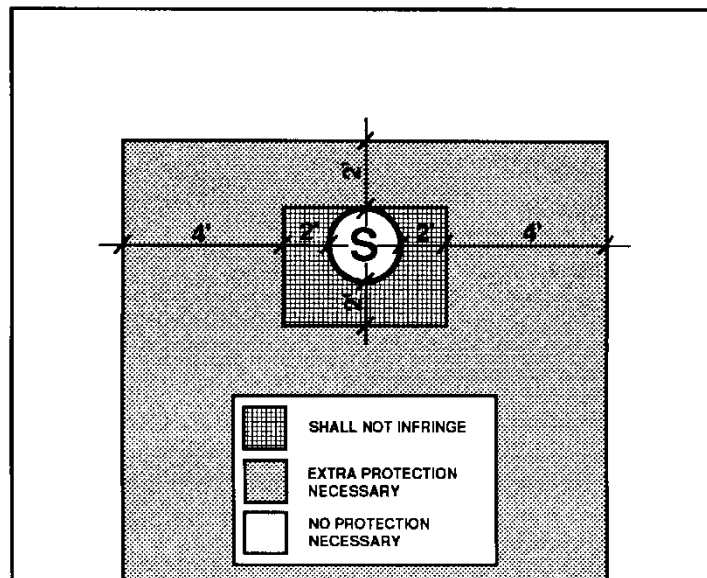

Under no circumstances will the horizontal separation between sewer mains and water mains be less than two feet (2'). All distances are to be measured from the outside of the sewer main to the outside of the water main.

- b. Vertical - When a water main is parallel with or crosses a sewer main within two feet (2') above the sewer or greater than two feet (2') below the sewer, extra protection will be required. Extra protection shall consist of constructing the sewer main with mechanical joint ductile iron pipe or with slip-joint ductile iron pipe if joint restraint is provided, or encasing both the water main and sewer main in concrete. See Detail E-9-30-1 and E-9-30-2.

The Construction Drawings shall indicate the installation requirements. The drawings showing these exceptions shall have been approved by the appropriate state and/or county health department.

Under no circumstances will the vertical separation of a sewer main installed above a water main be less than two feet (2'). All distances are to be measured from the outside of the sewer main to the outside of the water main. Refer to the diagram above for clarification.

- c. When unusual conditions such as, but not limited to, highway or bridge crossings prevent the water and sewer main separations required from being met, the appropriate state and/or county health department will review and may approve requests for authorization to use alternate construction techniques, materials and joints on a case-by-case basis.
- d. No water pipe shall pass through or come into contact with any part of a sewer manhole. The minimum horizontal separation between water mains and manholes shall be six feet (6'), measured from the center of the manhole.
- e. The minimum separation between force mains or pressure sewers and water mains shall be two feet (2') vertically and six feet (6') horizontally under all conditions. Where a sewer force main crosses above, or less than six feet (6') below, a water line, the sewer main shall be encased in at least six inches (6") of concrete for ten feet (10') on either side of the water main. Refer to the diagram below for clarification.

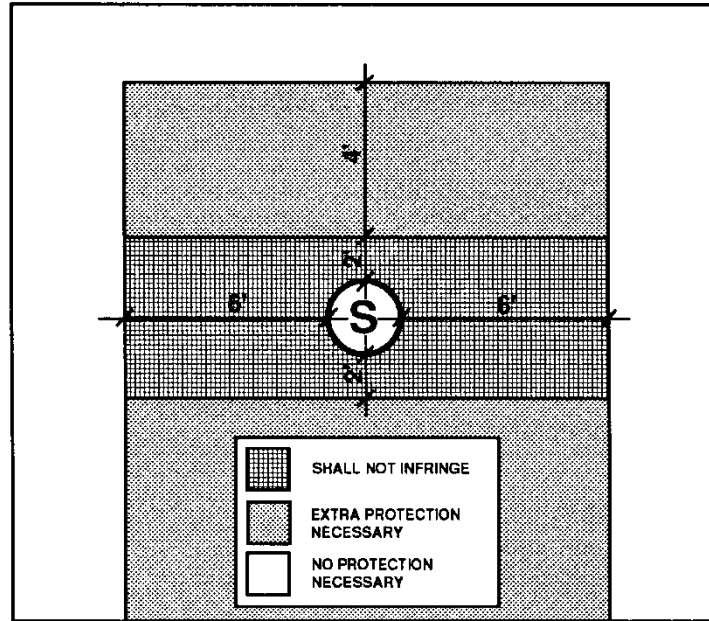

- f. Sewer mains (gravity, pressure, force) shall be kept a minimum of fifty feet (50') from drinking water wells, unless the following conditions are met:
1. Water main pipe, pressure tested in place to 50 psi without excessive leakage, may be used for gravity sewers at distances greater than twenty feet (20') from drinking water wells.
 2. Water main pipe, pressure tested in place to 150 psi without excessive leakage, may be used for pressure sewers and force mains at distances greater than twenty feet (20') from drinking water wells.
- g. No septic tank/disposal field system shall be constructed within one hundred feet (100') of a drinking water well.
- h. All distances are measured perpendicularly from the outside of the sewer main to the outside of the water main. These separation requirements do not apply to building, plumbing or individual house service connections.
- i. Use Mechanical Joint ductile iron pipe with Megalug thrust restraints a minimum of ten (10') feet on each side of a sewer or storm drain crossing.

11. COMPACTION

When crossing existing water mains a minimum of 95% compaction is required to the bottom of existing mains.

Arizona Water Company requires that no slurry be permitted to contact existing cement/asbestos or ductile iron pipes, unless authorized by the company. Slurry may be poured in the bottom of the sewer trench stopping three inches (3") below the existing water main. The backfill used around the main should be AB in sufficient depth to prevent slurry from contacting existing main.

12. WATER MAIN MATERIAL SPECIFICATIONS

Ductile iron pipe (Push-on type) minimum class 350, cement lined and conform to AWWA C151.

All main line valves shall conform to AWWA C500 with a minimum working pressure of 200 psi.

All cast iron fittings to be cement lined in accordance with AWWA C104 and shall conform to AWWA C110 with a minimum working pressure of 250 psi. Except for the Coolidge System – See Note 4L.

Maximum joint deflection for 6" mechanical joint ductile iron pipe is seven degrees, seven minutes ($7^{\circ}, 7'$) or twenty-seven inches (27") per eighteen-foot (18') length pipe, for a maximum curve of one hundred forty-five feet (145').

Maximum joint deflection for 8" and 12" mechanical joint ductile iron pipe is five degrees, twenty-one minutes ($5^{\circ} 21'$) or twenty inches (20") per eighteen-foot (18') length pipe, for a maximum curve of one hundred ninety-five feet (195').

Maximum joint deflection for 6", 8" and 12" push-on joint ductile iron pipe is five degrees (5°) or nineteen inches (19") per eighteen-foot (18') length pipe for a maximum curve of two hundred five feet (205').

ARIZONA WATER COMPANY

3805 N. BLACK CANYON HIGHWAY, PHOENIX, ARIZONA 85015-5351 • P.O. BOX 29006, PHOENIX, ARIZONA 85038-9006
PHONE: (602) 240-6860 • FAX: (602) 240-6878 • WWW.AZWATER.COM

October 19, 2010

Mr. Jim Ryan
Clow Valve Company
8121 N. 10th Avenue
Phoenix, Arizona 85021

Re: Clow Medallion Fire Hydrants and Resilient Wedge Gate Valves

Dear Mr. Ryan:

Thank you for your interest in working with Arizona Water Company (the "Company") to add Clow Medallion Fire Hydrants and Resilient Wedge Gate Valves to the Company's material and equipment specifications. Based on the Clow product information you provided and your field presentations to our operations and engineering staff, the Company is pleased to inform you that the following items are approved for use in the Company's water systems in Arizona.

Medallion Fire Hydrant:

- Model F-2545
 - 5¼" MVO
 - 4½" pumper
 - 2½" hose
 - Meets AWWA C-502 standard and approval by ULFM

Resilient Wedge Gate Valves:

- Model 2639 & 2640
 - Meets AWWA C-509 Full Body Cast Iron includes 304 SS Nuts, Bolts & Low Zinc Bronze Stem
 - Size range 2½" thru 12"
- Model 2638
 - Meets AWWA C-515 Reduced Wall Ductile Iron includes 304 SS Nuts, Bolts & Low Zinc Bronze Stem
 - Size range 14" thru 48"

E-MAIL: mail@azwater.com

ARIZONA WATER COMPANY

To: Jim Ryan – Clow Valve Company
Subject: Clow Medallion Fire Hydrants and Resilient Wedge Gate Valves

October 19, 2010
Page 2

We look forward to developing a long-term relationship with you and the Clow products.
If I can be of any assistance, please call me.

Very truly yours,



Fredrick K. Schneider
Vice President – Engineering

lar

VIA EMAIL: JIM.RYAN@CLOWVALVE.COM

ARIZONA WATER COMPANY

3805 N. BLACK CANYON HIGHWAY, PHOENIX, ARIZONA 85015-5351 • P.O. BOX 29006, PHOENIX, ARIZONA 85038-9006
PHONE: (602) 240-6860 • FAX: (602) 240-6878 • WWW.AZWATER.COM

November 24, 2010

Mr. Tony Geiger
US Pipe – Waterworks Marketing Consultants
34522 N. Scottsdale Road
Scottsdale, Arizona 85226

Re: US Pipe Sentinel Fire Hydrants and Resilient Wedge Gate Valves

Dear Mr. Geiger:

Thank you for your interest in working with Arizona Water Company (the "Company") to add US Pipe Sentinel Fire Hydrants and Resilient Wedge Gate Valves to the Company's material and equipment specifications. Based on the US Pipe product information you provided and your field presentations to our operations and engineering staff, the Company is pleased to inform you that the following items are approved for use in the Company's water systems in Arizona.

Sentinel Fire Hydrant:

- Model Sentinel 250
 - 5¼" MVO
 - 4½" pumper
 - 2½" hose
 - Meets AWWA C-502 standard and approval by ULFM

Resilient Wedge Gate Valves:

- Model US Pipe A-USP0
 - Meets AWWA C-509 Full Body Cast Iron includes 304 SS Nuts, Bolts & Low Zinc Bronze Stem
 - Size range 2" thru 12"
- Model US Pipe A-USP1
 - Meets AWWA C-515 Reduced Wall Ductile Iron includes 304 SS Nuts, Bolts & Low Zinc Bronze Stem
 - Size range 14" thru 48"

E-MAIL: marketing@azwater.com

ARIZONA WATER COMPANY

To: Tony Geiger – US Pipe

November 24, 2010

Subject: US Pipe Sentinel Fire Hydrants and Resilient Wedge Gate Valves

Page 2

We look forward to developing a long-term relationship with you and the US Pipe products. If I can be of any assistance, please call me.

Very truly yours,



Fredrick K. Schneider
Vice President – Engineering

afh

VIA EMAIL: TGEIGER4@COX.NET

ARIZONA WATER COMPANY

3805 N. BLACK CANYON HIGHWAY, PHOENIX, AZ 85015-5351 • P.O. BOX 29006, PHOENIX, AZ 85038-9006
PHONE: (602) 240-6860 • FAX: (602) 240-6874 • TOLL FREE: (800) 533-6023 • www.azwater.com

February 21, 2012

Contractor

Re: Fitting Specifications

Dear Contractor:

Effective March 1, 2012, Arizona Water Company (the "Company") has changed its fitting specifications for Ductile Iron Fittings and Ductile Iron Flanged Fittings ("Fittings"). All Fittings purchased by the Company, on the Company's behalf or installed with the intent of being conveyed to the Company, must comply with the requirements noted below.

Previous Fitting Specifications:

Fittings

Manufactured by Tyler or Union, Crosses, Elbows, Tees, Cap Reducer, Adapter, Plug, Blind Flange and Tapped Flange: Ductile Iron, Class 350, SSB, and Cast Iron Cement Lined.

New Fitting Specification:

Ductile Iron Fittings (Push-On and Mechanical Joint)

Ductile Iron Push-On and Mechanical Joint ("MJ") fittings for water lines shall be made of ductile iron per ASTM A536 and be cast in the United States of America. Fittings shall have USA cast on the fitting to designate they are made in the United States. All fittings will be manufactured and tested in accordance with ANSI/AWWA C153/A21.53 for compact design and ANSI/AWWA C110/A21.10 for full body design. In accordance with ANSI/AWWA C104/A21.4 fittings 2" – 3" will be single thickness cement mortar lined and 4" – 64" will be cement mortar lined. Fittings will be Asphaltic seal coated on the exterior in accordance with ANSI/AWWA C104/A21.4. MJ fittings with flanged end(s) will match ANSI/AWWA C115/A21.15 and ANSI B16.1 class 125 flanges. All fittings shall be NSF-61 listed for use with potable water.

Ductile Iron Flanged Fittings

E-MAIL: mail@azwater.com

Ductile Iron flanged fittings for water lines shall be made of ductile iron per ASTM A536 and be cast in the United States of America. Fittings shall have USA cast on the fitting to designate they are made in the United States. All fittings will be manufactured and tested in accordance with ANSI/AWWA C110/A21.10 design. Flange ends will match ANSI/AWWA C115/A21.15 and ANSI B16.1 class 125 flanges. In accordance with ANSI/AWWA C104/A21.4 fittings 2" – 3" will be single thickness lined and 4" – 64" will be cement mortar lined. Fittings will be Asphaltic seal coated on the exterior in accordance with ANSI/AWWA C104/A21.4. All fittings shall be NSF-61 listed for use with potable water.

If you have any questions or require further information, please contact me at 602-240-6860.

Very truly yours,



Fredrick K. Schneider, PE
Vice President - Engineering
engineering@azwater.com

afh
Enclosure

ARIZONA WATER COMPANY

3805 N. BLACK CANYON HIGHWAY, PHOENIX, ARIZONA 85015-5351 • P.O. BOX 29006, PHOENIX, AZ 85038-9006
PHONE: (602) 240-6860 • FAX: (602) 240-6874 • TOLL FREE: (800) 533-6023 • www.azwater.com

November 28, 2016

Mr. David Shelton
Mueller Company
2557 N. Silverado
Mesa, AZ 85215

Re: Mueller Resilient Wedge Gate Valves

Dear Mr. Shelton:

Thank you for your interest in working with Arizona Water Company (the "Company") to add Mueller Full Body Ductile Iron Resilient Wedge Gate Valves to the Company's material and equipment specifications. Based on the Mueller Company's product information you provided to the Company, the Company is pleased to inform you that the following items are approved for use in the Company's water systems in Arizona.

Resilient Wedge Gate Valves:

- Model 2362 Full Body Ductile Iron Gate Valve
 - Complies with AWWA C-509 specifications
 - Gate valves must include 304 SS nuts, bolts and a low zinc bronze stem
 - Size range 2 ½" thru 12"

We look forward to continuing our long-term relationship with you and the Mueller products. If I can be of any assistance, please call me.

Very truly yours,



Fredrick K. Schneider
Vice President – Engineering

ajh

ARIZONA WATER COMPANY

3805 N. BLACK CANYON HIGHWAY, PHOENIX, AZ 85015-5351 • P.O. BOX 29006, PHOENIX, AZ 85038-9006
PHONE: (602) 240-6860 • FAX: (602) 240-6874 • TOLL FREE: (800) 533-6023 • www.azwater.com

June 15, 2017

Mr. Tony Geiger
US Pipe – Waterworks Marketing Consultants
34522 N. Scottsdale Road
Scottsdale, AZ 85226

Re: Resilient Wedge Gate Valves

Dear Mr. Geiger:

Thank you for your interest in working with Arizona Water Company (the "Company") to add US Full Body Ductile Iron Resilient Wedge Gate Valves to the Company's material and equipment specifications. Based on the US Pipe Company's product information you provided to the Company, the Company is pleased to inform you that the following items are approved for use in the Company's water systems in Arizona.

Resilient Wedge Gate Valves:

- Model USP2 Full Body Ductile Iron Gate Valve
 - Meets AWWA C-509 Full Body Cast Iron includes 304 SS Nuts, Bolts & Low Zinc Bronze Stem.
 - Size range 2" thru 12"

We look forward to continuing our long-term relationship with you and the US Pipe products. If I can be of any assistance, please call me.

Very truly yours,



Fredrick K. Schneider, P. E.
Vice President - Engineering
fschneider@azwater.com

afh
Enclosure

E-MAIL: engineering@azwater.com

ARIZONA WATER COMPANY

3805 N. BLACK CANYON HIGHWAY, PHOENIX, AZ 85015-5351 • P.O. BOX 29006, PHOENIX, AZ 85038-9006
PHONE: (602) 240-6860 • FAX: (602) 240-6874 • TOLL FREE: (800) 533-6023 • www.azwater.com

January 25, 2018

Contractor

Re: Mechanical Joint Restraint

Dear Contractor:

Effective January 25, 2018, Arizona Water Company (the "Company") has changed its mechanical joint restraint specifications for MEGA LUG mechanical joint restraints. All mechanical joint restraints purchased by the Company, on the Company's behalf, or installed with the intent of being conveyed to the Company, must comply with the requirements noted below.

Previous Mechanical Joint Restraint Specification:

MEGA LUG: Mechanical joint restraint made of ductile iron conforming to ASTM 536-80, 250 psi made by EBAA Iron, Inc., series 1100 or equal.

New Mechanical Joint Restraint Specification:

Ductile Iron Mechanical Joint Restraints for water lines shall be made of ductile iron per ASTM A536 and be cast in the United States of America. Mechanical Joint Restraints shall have USA cast on the mechanical joint restraint to designate they are made in the United States. All mechanical joint restraints will be manufactured in accordance with ANSI/AWWA C110/A21.10. The mechanical joint restraints will have a minimum working pressure rating of 350 psi for pipe diameters ranging from 3-inch to 16-inch, and minimum 250 psi pressure rating for pipe diameters ranging from 18-inch to 48-inch. All mechanical joint restraints will have UL Certification for pipe diameters ranging from 3-inch to 24-inch and will have Factory Mutual Research Approval from 3-inch to 12-inch.

The following manufacturers are approved for the following pipe diameters:

Manufacturer	Product Name	Pipe Diameters
EBAA Iron	MEGA LUG Series 1100	3-inch to 48-inch
Star Pipe	Star Grip Series 3000	3-inch to 48-inch
Tyler Union	TUF Grip Series 1000	4-inch to 48-inch

Very truly yours,



Fredrick K. Schneider, P. E.
Vice President-Engineering

gr

E-MAIL: mail@azwater.com

ARIZONA WATER COMPANY

STANDARD SPECIFICATION DRAWINGS: E-9-1

2010 REVISIONS

ARIZONA WATER COMPANY

STANDARD SPECIFICATION DRAWINGS

INDEX (E-9)

E-9-1-1	TYPICAL GATE VALVE LOCATIONS
E-9-2-1	TYPICAL VERTICAL GATE VALVES
E-9-2-2	INSTALLATION OF BEVEL GEARED HORIZONTAL GATE VALVES WITHOUT A BY-PASS FOR 18-INCH AND LARGER VALVES
E-9-2-3	INSTALLATION OF BEVEL GEARED HORIZONTAL GATE VALVES WITH BY-PASS FOR 18-INCH AND LARGER VALVES
E-9-3-1	TYPICAL TAPPING SLEEVE AND VALVE
E-9-4-1	TYPICAL VALVE SUBJECT TO NON-VEHICULAR AND VEHICULAR TRAFFIC
E-9-5-1	TYPICAL THRUST BLOCKING SCHEDULE
E-9-5-2	THRUST BLOCK FOR VERTICAL BENDS
E-9-5-3-1	JOINT RESTRAINT FOR NEW DUCTILE IRON AND C-900 PVC
E-9-5-3-2	JOINT RESTRAINT FOR NEW DUCTILE IRON AND C-900 MAINS
E-9-6-1	TYPICAL PERPENDICULAR FIRE HYDRANT
E-9-7-1	TYPICAL PARALLEL FIRE HYDRANT
E-9-8-1	2-INCH BLOWOFF ASSEMBLY
E-9-8-2	TYPICAL AIR RELEASE VALVE
E-9-8-3	AIR RELEASE VALVE FOR THE NORTHERN REGION
E-9-9-1	SINGLE SERVICE CONNECTION FOR A 5/8-INCH METER
E-9-10-1	SINGLE SERVICE CONNECTION FOR 1-INCH METER
E-9-10-2	DOUBLE SERVICE CONNECTION FOR 1-INCH METER
E-9-11-1	TYPICAL 2-INCH SERVICE CONNECTIONS
E-9-12-1	3-INCH COMPOUND METER
E-9-12-2	4-INCH COMPOUND METER
E-9-12-3	6-INCH COMPOUND METER

E-9-12-4 6-INCH COMPOUND SERVICE

E-9-12-5 CONCRETE VAULT

E-9-12-6 NON-POTABLE PROPELLER METER

E-9-13-1 TYPICAL 4-INCH THRU 8-INCH DETECTOR CHECK VALVES

E-9-13-2 DOUBLE CHECK VALVE DETECTOR ASSEMBLY FOR 3-INCH THRU 10-INCH FIRELINE SERVICES

E-9-14-1 TYPICAL PRESSURE RELIEF VALVE ASSEMBLY

E-9-14-2 PRESSURE RELIEF VALVE - NORTHERN REGION

E-9-15-1 TYPICAL PRESSURE REDUCING STATION

E-9-16-1 PAINT COLOR SELECTION

E-9-17-1 STEEL WATER STORAGE TANK

E-9-18-1 HYDROPNEUMATIC TANK

E-9-19-1 TYPICAL DOMESTIC WATER SUPPLY WELL

E-9-20-1 TYPICAL WELL WITH LINE SHAFT TURBINE PUMP

E-9-21-1 TYPICAL WELL WITH SUBMERSIBLE TURBINE PUMP

E-9-22-1 COLUMN PIPE, OIL TUBE AND LINE SHAFT

E-9-23-1 HOT TAP & JUMPER METER CONNECTION

E-9-24-1 TYPICAL WATER LINE ENCASEMENT

E-9-25-1 CALCIUM HYPOCHLORITE TABLET CHLORINATOR

E-9-26-1 6'0" TALL CHAIN LINK FENCE

E-9-27-1 SIDE HUNG WATER LINE SUSPENSION

E-9-28-1 PIPE WARNING TAPE AND LOCATOR WIRE

E-9-28-2 LOCATOR WIRE TERMINATION

E-9-29-1 SAMPLING STATION

E-9-30-1 WATER AND SANITARY SEWER SEPARATION/PROTECTION

E-9-30-2 WATER AND SANITARY SEWER SEPARATION/PROTECTION

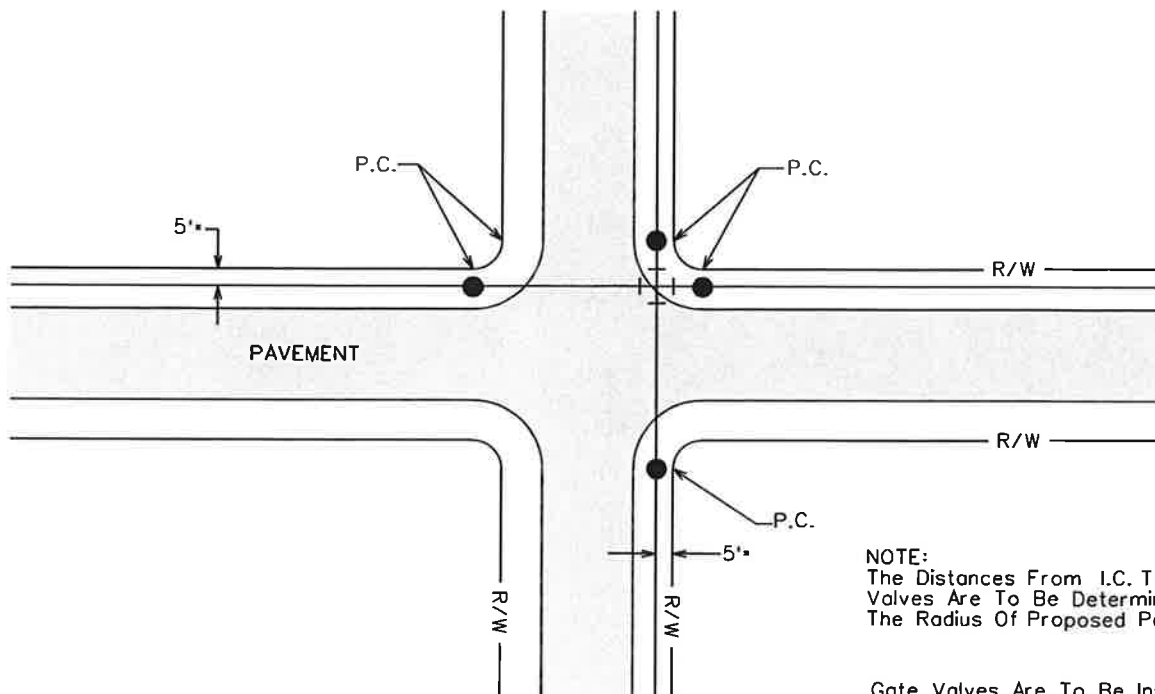

NOTE:
The Distances From I.C. To Gate Valves Are To Be Determined By The Radius Of Proposed Pavement.

Gate Valves Are To Be Installed In The Above Locations In Such A Manner That They Will Not Be Covered By Paving, Sidewalks, Or Curbs

*Location of water mains from the property line may require alteration for co-ordination with curb, sidewalk, or paving requirements. Variations are to be approved by the A.W.Co. Engineering dept.

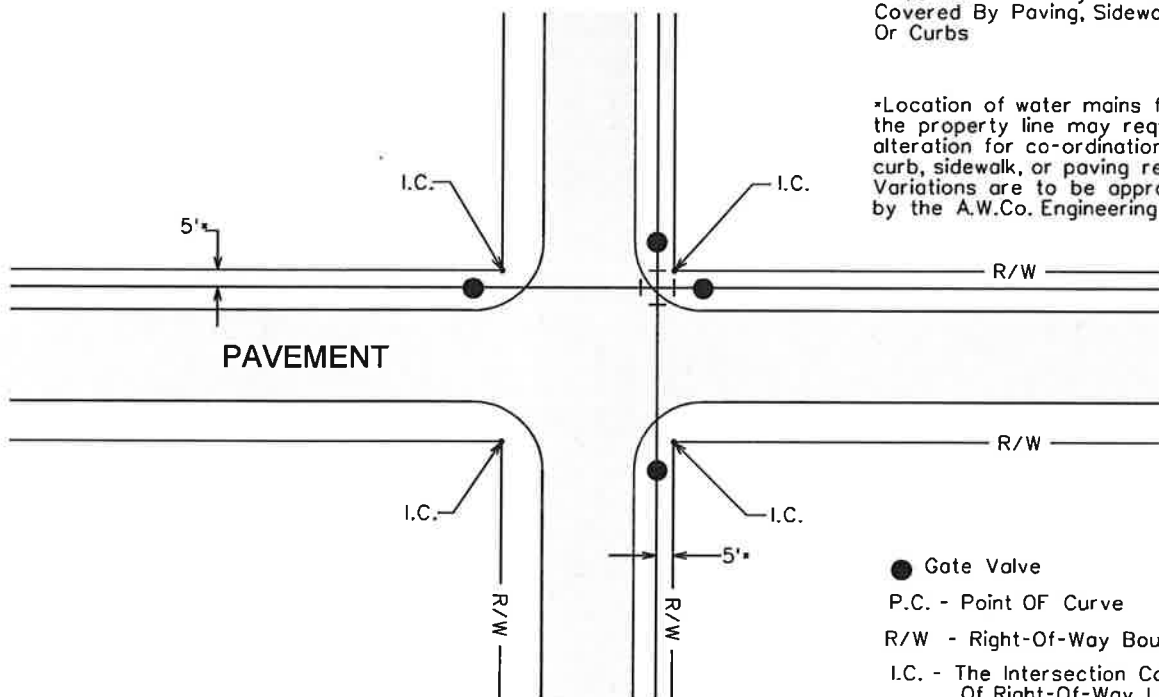

- Gate Valve
- P.C. - Point Of Curve
- R/W - Right-Of-Way Boundary
- I.C. - The Intersection Corner Of Right-Of-Way Lines

ARIZONA WATER COMPANY

STANDARD SPECIFICATION
FOR THE INSTALLATION OF

TYPICAL GATE VALVE LOCATIONS

DRAWN BY: CCO	APPROVED BY: M.W.	DATE: 3/20/86	△ 1/31/2001
			E-9-1-1

FOR 6" THROUGH 12" GATE VALVES

Mueller Resiliant Wedge Gate Valves
 Catalog Number A-2360-__
 ANSI/AWWA C509 Compliant

FOR 14" THROUGH 16" GATE VALVES

Mueller Resiliant Wedge Gate Valves
 Catalog Number A-2361-__
 ANSI/AWWA C509 Compliant

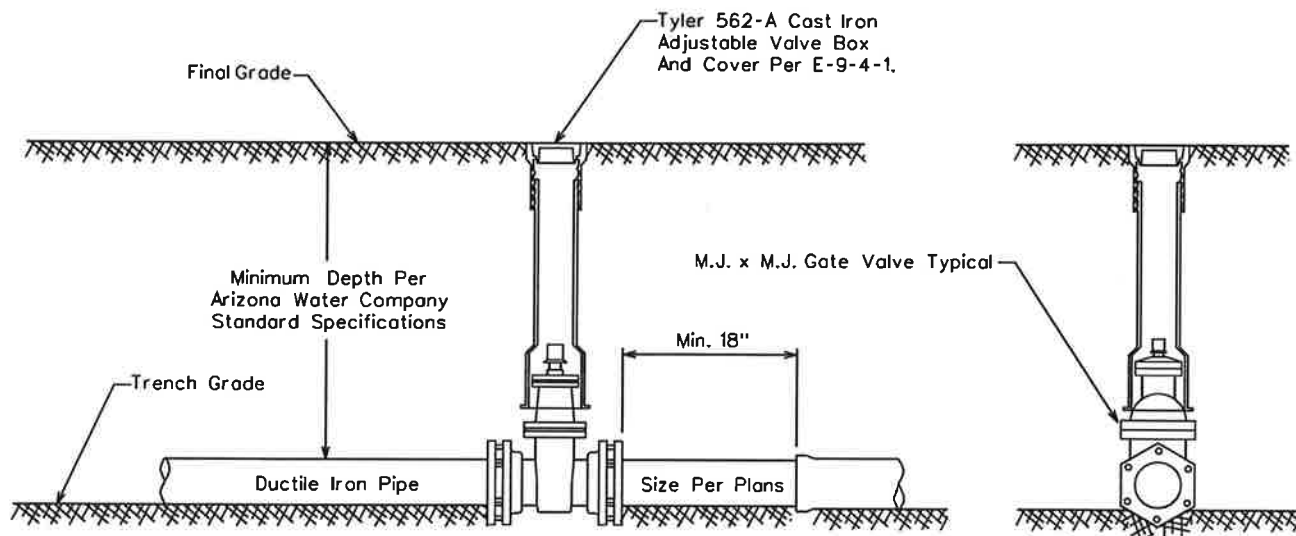

All Valves Installed On Pipe Five Feet (5') Deep And Greater Are To Be Installed With A Valve Operator Extension, Mueller Catalog No. A-26441.

ARIZONA WATER COMPANY

STANDARD SPECIFICATION
 FOR THE INSTALLATION OF

TYPICAL VERTICAL GATE VALVES

DRAWN BY: CB	APPROVED BY: MW	DATE: 03.20.1986	△ 08.23.2006	E-9-2-1
-----------------	--------------------	---------------------	--------------	---------

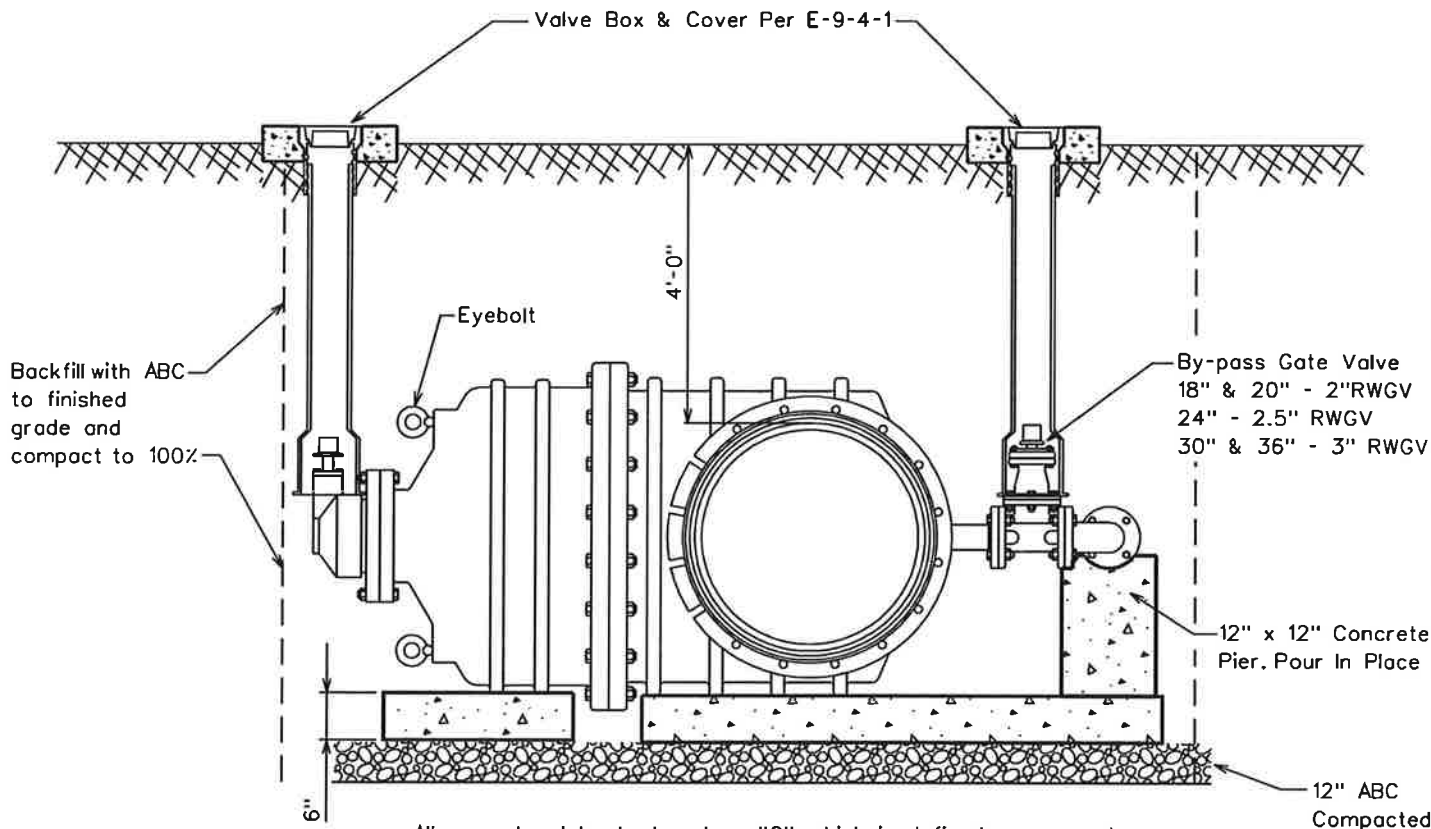

All concrete slabs to be class "C", which is defined as concrete whose minimum compressive strength at 14 days reaches 1600psi and at 28 days reaches 2000psi, per MAG Section 725, Table 725-1. Slabs to be formed and poured prior to valve installation.

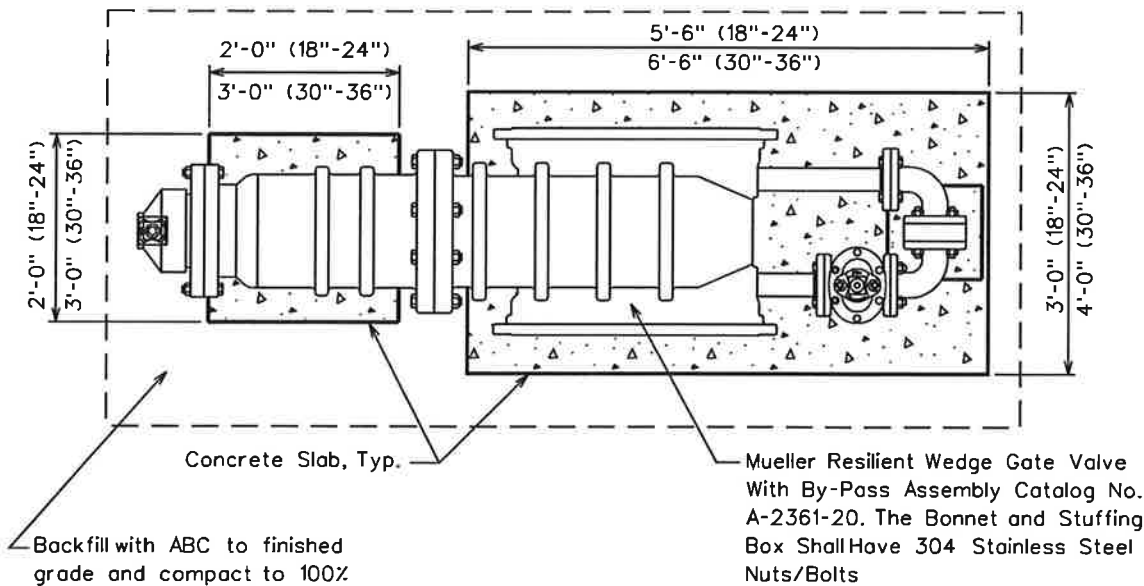

ARIZONA WATER COMPANY

All valves installed on pipe five feet and greater are to be installed with a valve operator extension Mueller catalog No. A-26441. The distance is measured from the top of the operating nut to final grade.

STANDARD SPECIFICATION			
FOR THE INSTALLATION OF			
INSTALLATION OF BEVEL GEARED HORIZONTAL GATE VALVES WITH BY-PASS FOR 18" AND LARGER VALVES			
DRAWN BY:	APPROVED BY:	DATE:	
CB		12.07.2004	△
			E-9-2-2

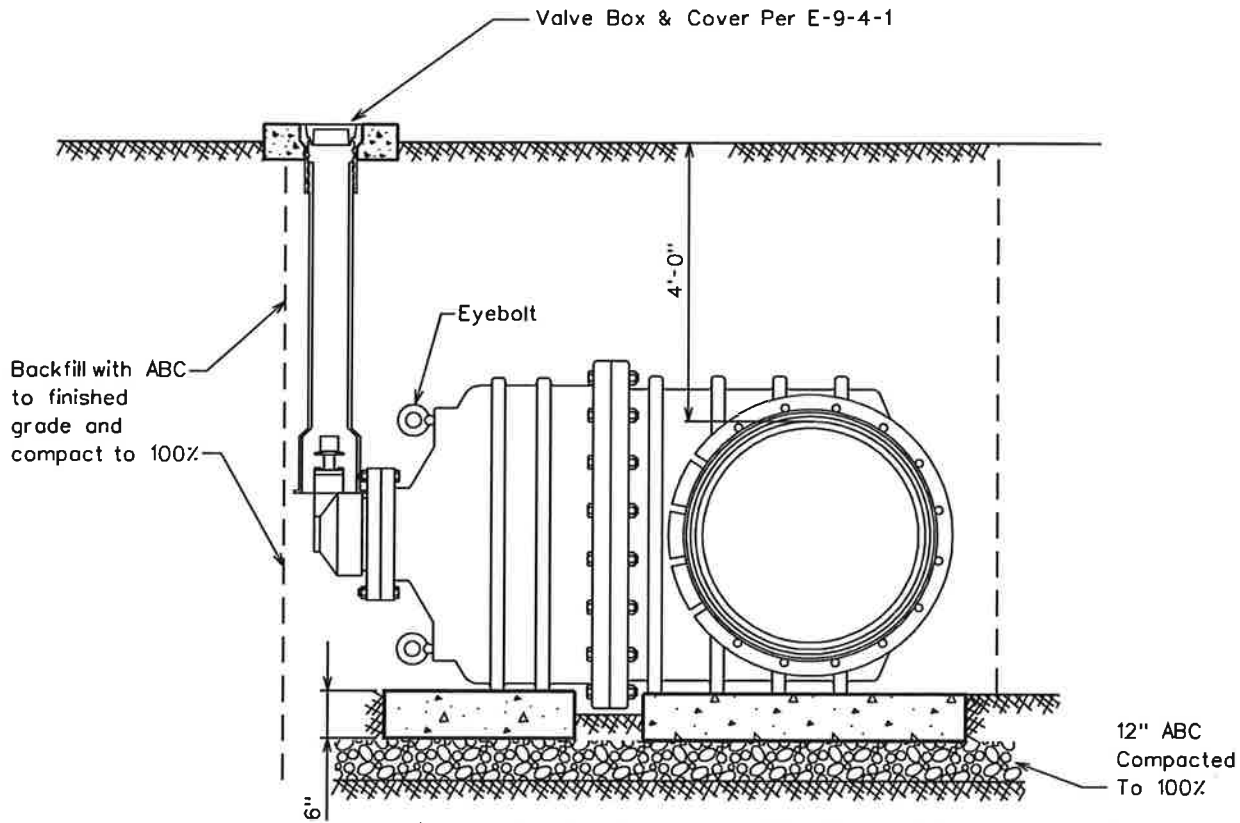

All concrete slabs to be class "C", which is defined as concrete whose minimum compressive strength at 14 days reaches 1600psi and at 28 days reaches 2000psi. per MAG Section 725, Table 725-1. Slabs to be formed and poured prior to valve installation.

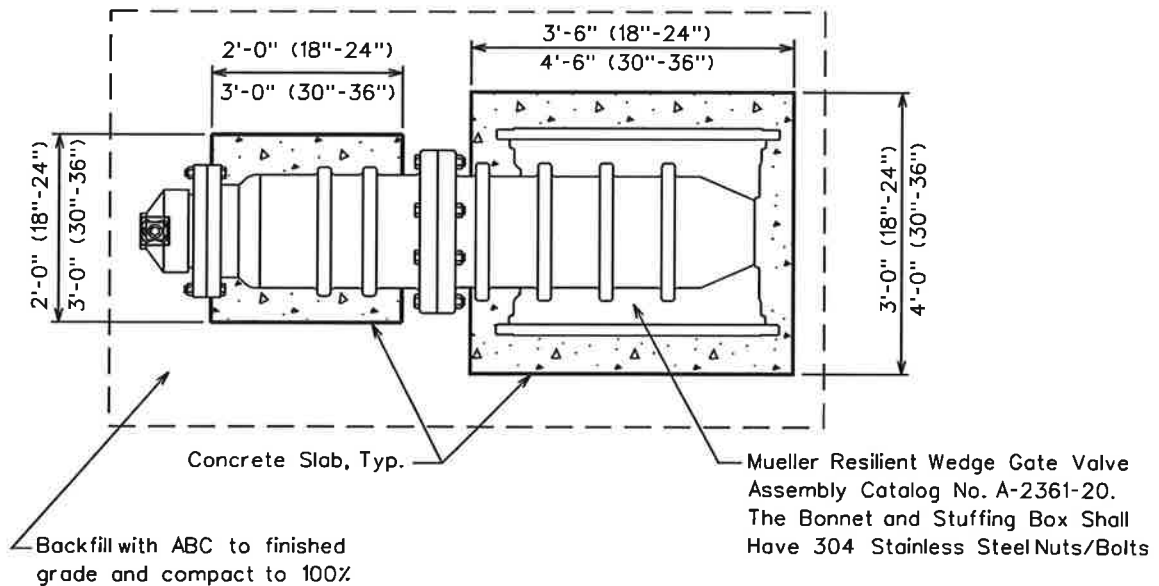

All valves installed on pipe five feet and greater are to be installed with a valve operator extension Mueller catalog No.A-26441 The distance is measured from the top of the operating nut to final grade.

ARIZONA WATER COMPANY

STANDARD SPECIFICATION FOR THE INSTALLATION OF

INSTALLATION OF BEVEL GEARED HORIZONTAL GATE VALVES WITHOUT A BY-PASS FOR 18" AND LARGER VALVES

DRAWN BY: CB	APPROVED BY:	DATE: 12.07.2004	△ 5.13.2005	E-9-2-3
-----------------	--------------	---------------------	-------------	---------

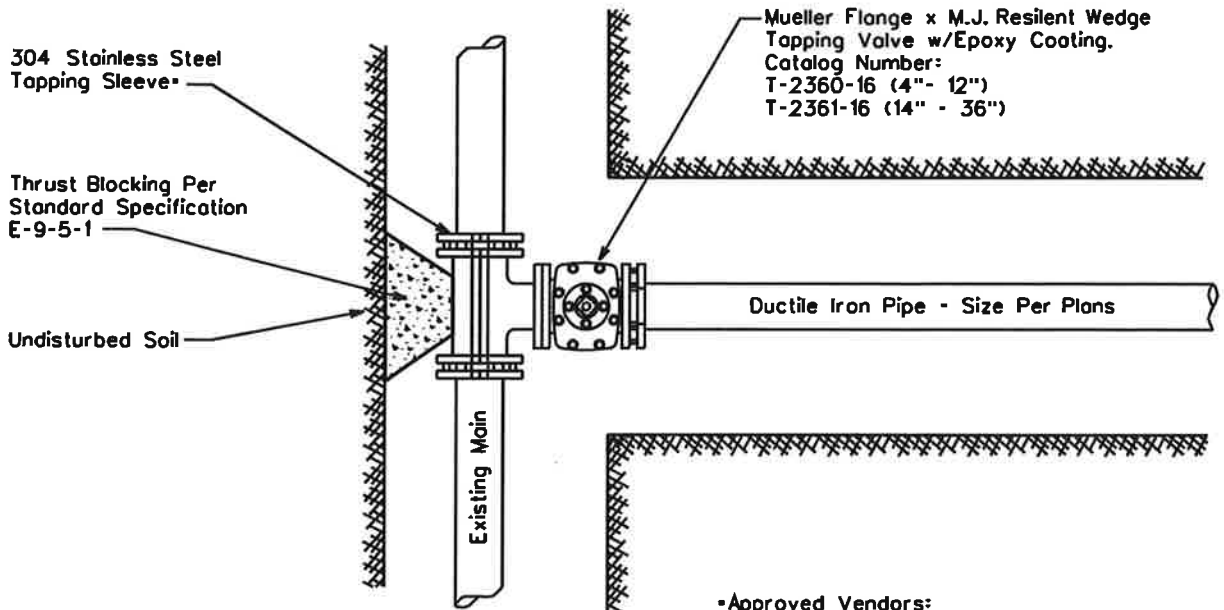

Mueller Flange x M.J. Resilient Wedge Tapping Valve w/Epoxy Coating.
 Catalog Number:
 T-2360-16 (4" - 12")
 T-2361-16 (14" - 36")

NOTE:

1. All flanges, bolts, and nuts shall be kept free of concrete.
2. Air pressure test the tapping sleeve before the live tap is made.
3. Polywrap all new fittings

Approved Vendors:

- Mueller, Catalog No. H304, 304 Stainless Steel
- JCM, Model 432, 304 Stainless Steel
- Romac, 'SST', 304 Stainless Steel
- Cascade, 'CST-EX', 304 Stainless Steel

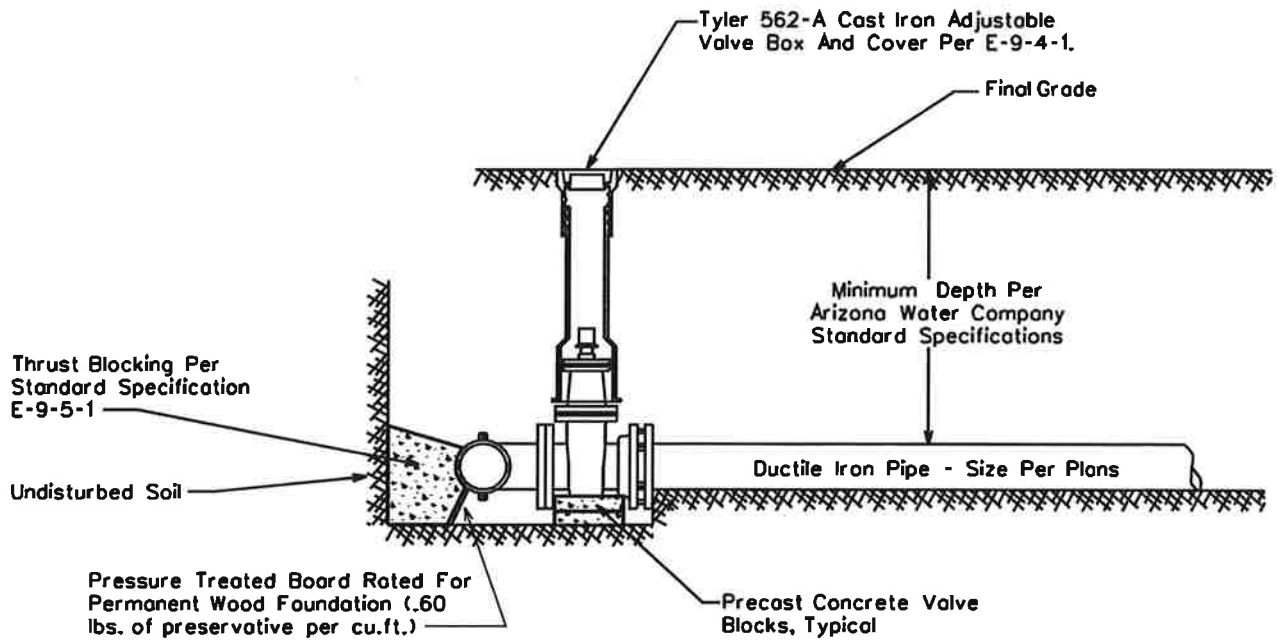

ARIZONA WATER COMPANY

STANDARD SPECIFICATION
 FOR THE INSTALLATION OF

TYPICAL TAPPING SLEEVE AND VALVE

DRAWN BY: CB	APPROVED BY: MW	DATE: 03.20.1986	△ 08.23.2006
-----------------	--------------------	---------------------	--------------

E-9-3-1

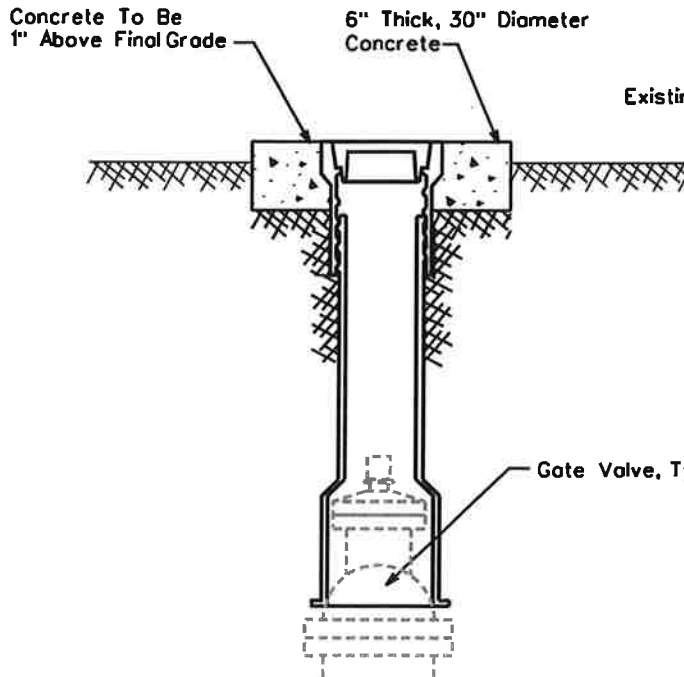

NON-VEHICULAR VALVE BOX

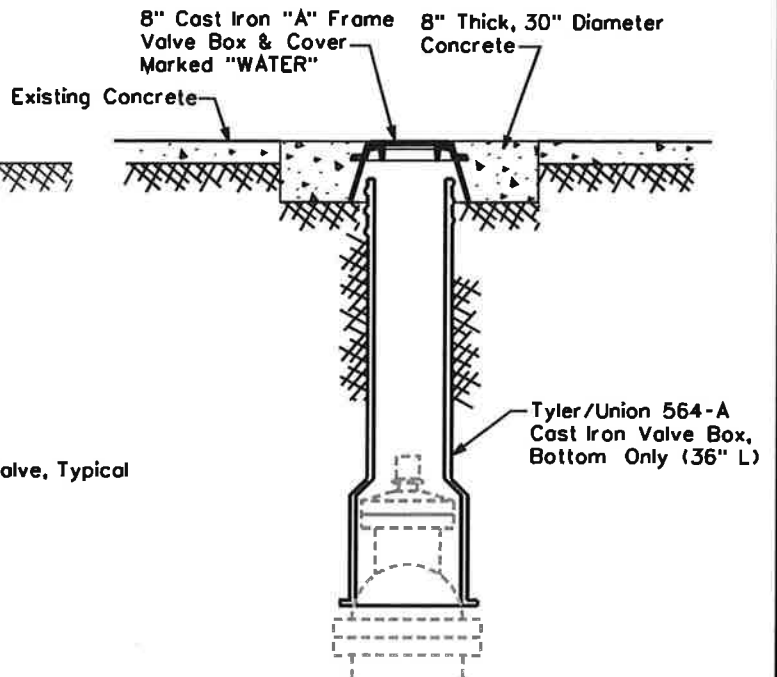

CONCRETE VALVE BOX

For Areas Subject To Vehicular Traffic

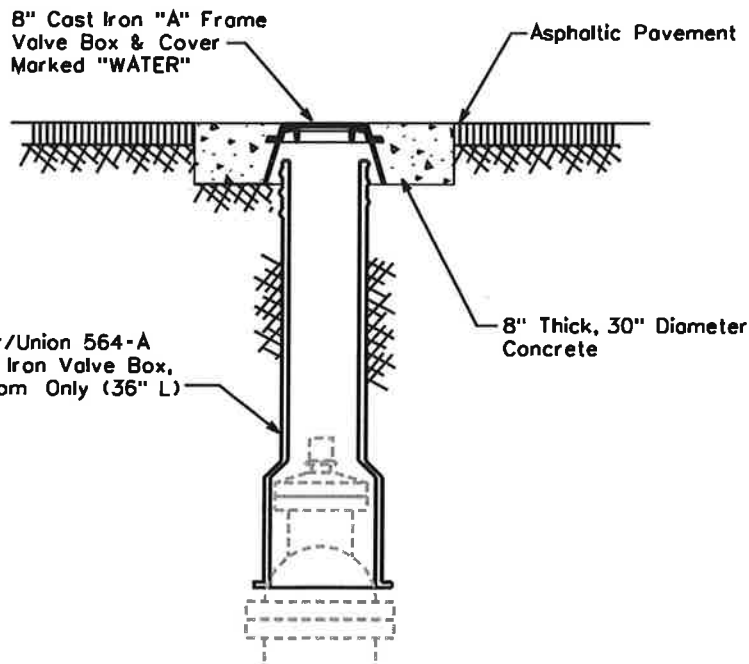

ASPHALT VALVE BOX

For Areas Subject To Vehicular Traffic

NOTE:

1. The Valve Box Shall Be Adjusted To Finished Grade Prior To Placing Of Asphalt And/Or Concrete.
2. For Non-Traffic Areas Use Tyler/Union 562-A, Two-Piece, 6855 Series Or Equivalent Adjustable Cast Iron Valve Box And Cover. Valves 4" To 12"
- For Traffic Areas, Use Tyler/Union 564-A Bottom Section Only With An 8" Cast Iron "A" Frame With Cover. Valves 4" To 12"
3. All Valves Installed Five Feet (5') Deep And Greater Are To Be Installed With A Valve Operator Extension, Mueller Catalog No. A-26441 And Shall Have A Debris Cap
4. Use Minimum Class 'C' Concrete which is defined as concrete whose minimum compressive strength at 14 days reaches 1600psi and at 28 days reaches 2000psi. per MAG Section 725, Table 725-1.

ARIZONA WATER COMPANY

STANDARD SPECIFICATION				
FOR THE INSTALLATION OF				
TYPICAL VALVE SUBJECT TO NON-VEHICULAR AND VEHICULAR TRAFFIC				
DRAWN BY:	CB	APPROVED BY:	MW	DATE:
				03.20.1986
				△ 8.24.2006
				E-9-4-1

CROSSES

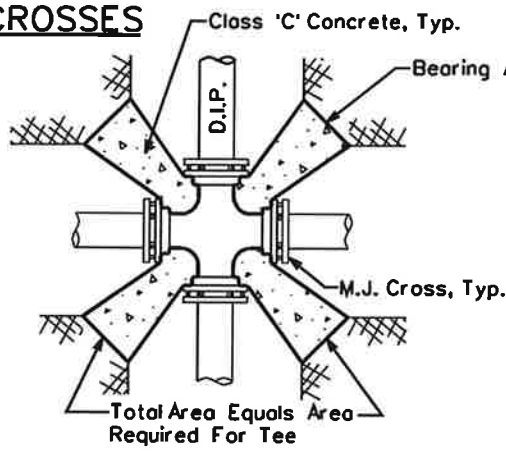

TEES

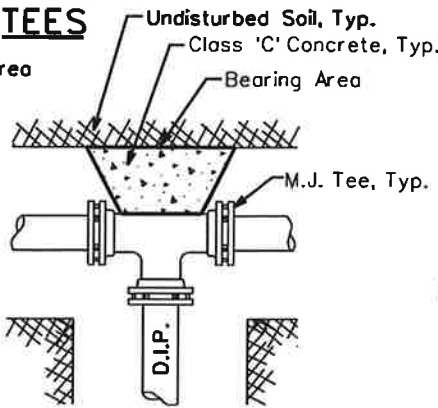

ELLS

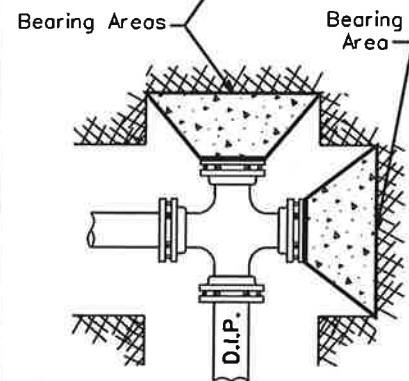
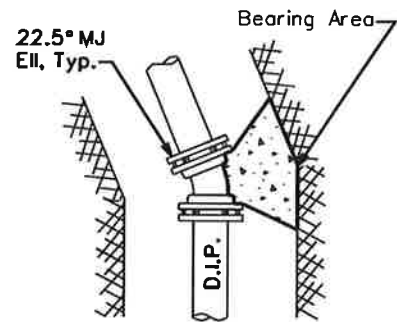
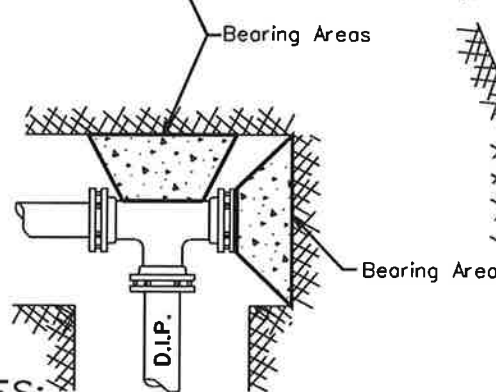
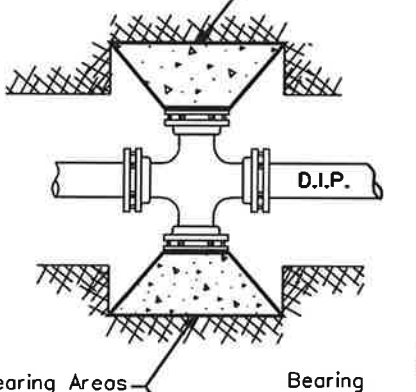
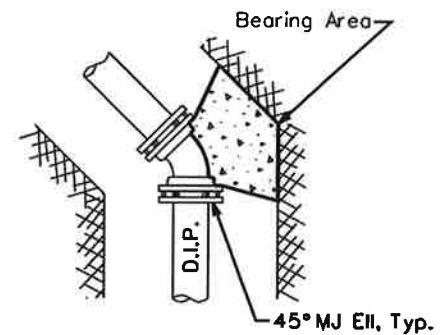
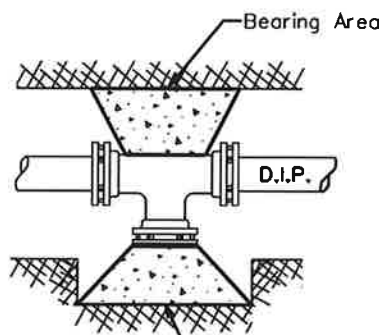
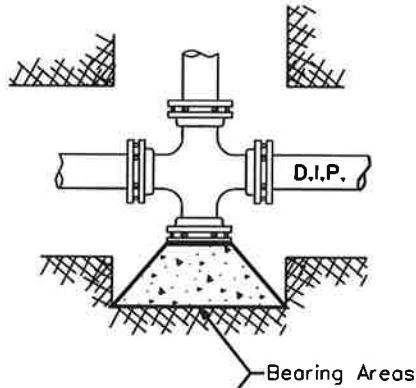
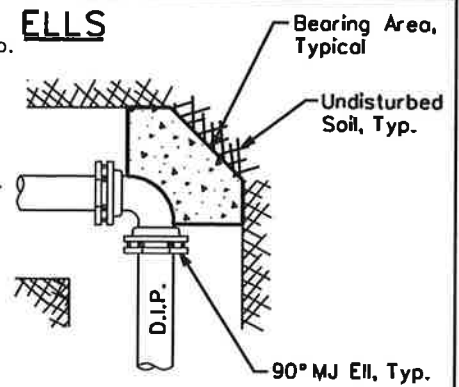

CROSS SECTION

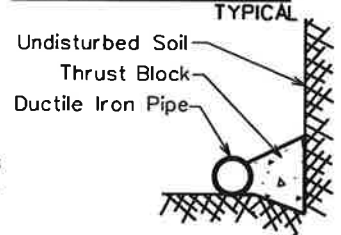

NOTES:

1. Use minimum Class 'C' concrete, which is defined as concrete whose minimum compressive strength at 14 days reaches 1600psi and at 28 days reaches 2000psi. per MAG Section 725, Table 725-1.
2. Thrust blocks are to bear on undisturbed earth with minimum bearing area as shown. If not undisturbed, areas will be increased as required.
3. Place the pressure treated form board in front of all plugs before pouring thrust blocks.
4. Form all non-bearing areas to prevent any concrete from entering any joint.
5. All flanges, bolts and nuts shall be kept free of concrete.
6. Center the bearing area on the pipe centerline and force line.
7. All pipe fittings to be wrapped with polyethylene pipe wrap prior to thrust block installation. (where applicable)

THRUST BLOCK SCHEDULE

PIPE SIZE	TEE, 45°, AND 22.5° ELLS, & PLUGS	90° ELLS
6" And Under	4 Sq.Ft.	6 Sq.Ft.
8"	6 Sq.Ft.	9 Sq.Ft.
12"	13 Sq.Ft.	20 Sq.Ft.
16"	23 Sq.Ft.	32 Sq.Ft.
18" And Larger	Calculated Per Project	

CAPS

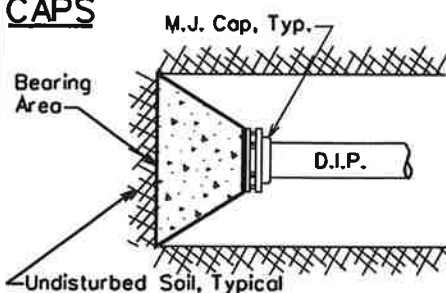

STANDARD SPECIFICATION

FOR THE INSTALLATION OF

TYPICAL THRUST BLOCKING SCHEDULE

DRAWN BY: CB APPROVED BY: MW DATE: 03.20.1986 △ 05.27.2005 E-9-5-1

NOTES

1. Bars In Conc. Thrust Block To Be Coated w/ 2 Coats Coal Tar Epoxy or by Other Approved Method.
2. Bars To Have 90° Hook @ Their Ends, As Per Table Below.

Pipe Size	Min. Bar Size	"A" Dimension (Hook)	Min. Block Dimension (WxHxL)
6"	#6	6"	3'x3'x3'
8"	#6	9"	4'x3'x4'
12"	#8	9"	5'x4'x5'
16"	#9	12"	7'x6'x7'

* For 125 P.S.I. Working Pressure

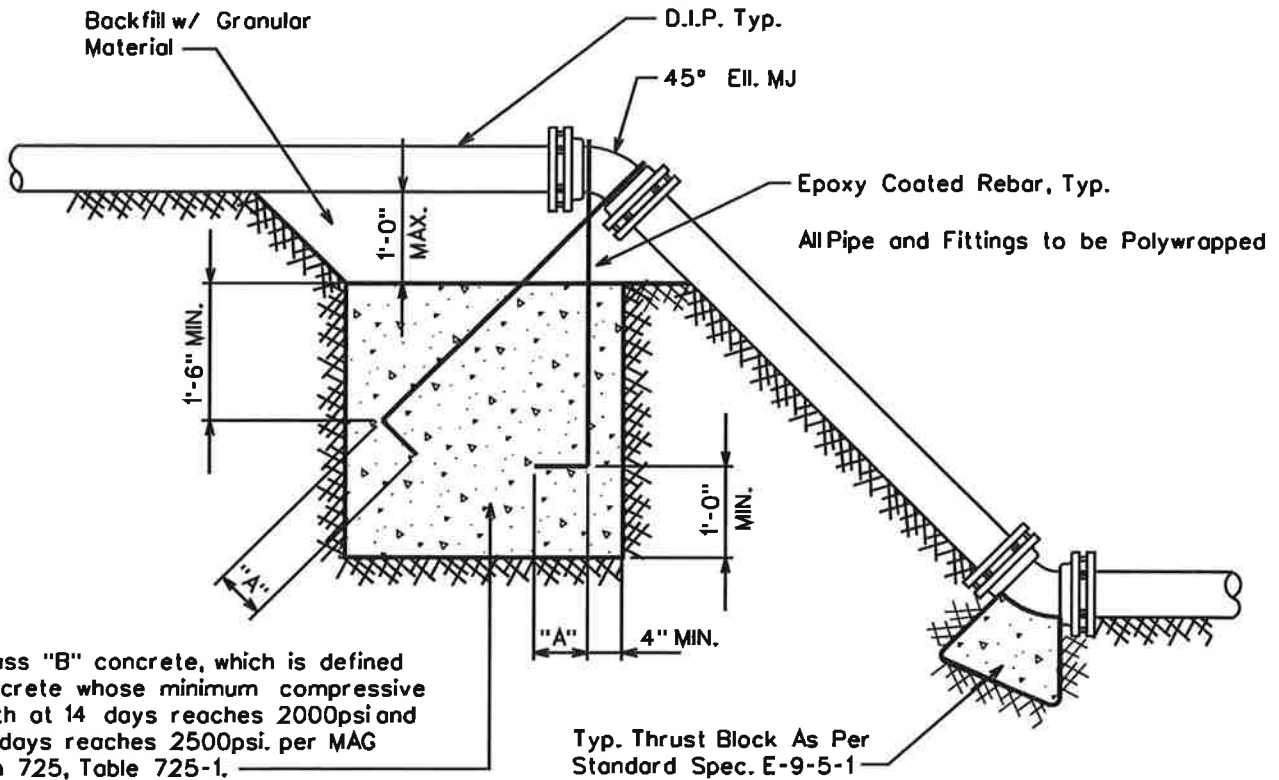

Min. Class "B" concrete, which is defined as concrete whose minimum compressive strength at 14 days reaches 2000psi and at 28 days reaches 2500psi. per MAG Section 725, Table 725-1.

Typ. Thrust Block As Per Standard Spec. E-9-5-1

ARIZONA WATER COMPANY

STANDARD SPECIFICATION FOR THE INSTALLATION OF			
THRUST BLOCK FOR VERTICAL BENDS			
DRAWN BY: JPK	APPROVED BY: MJW	DATE: 7-5-96	△ 01.16.2007
			E-9-5-2

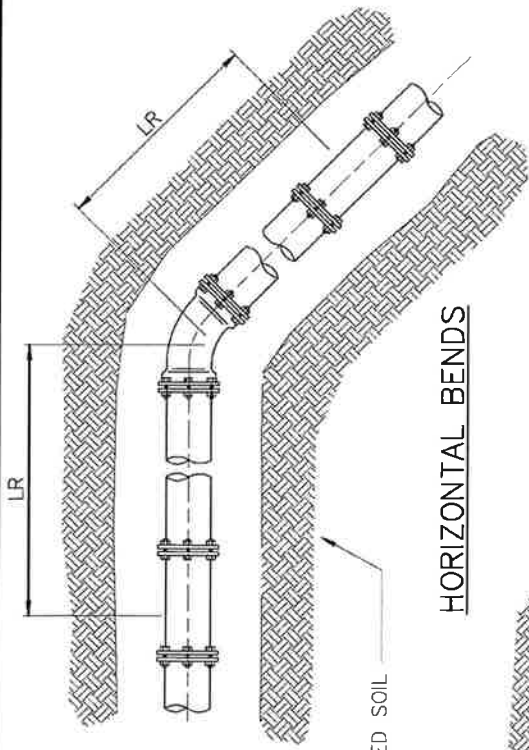

HORIZONTAL BENDS

UNDISTURBED SOIL

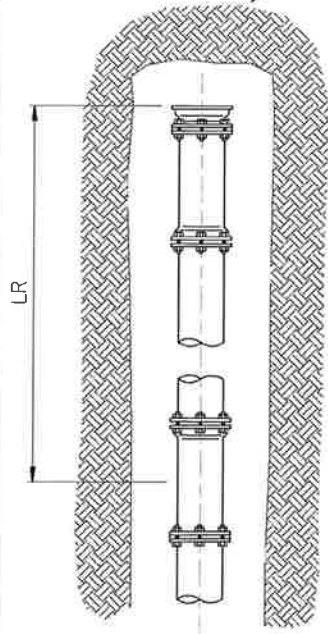

DEAD ENDS

LRN = SHORTEST LENGTH OF PIPE RESTRAINED TO THE RUN OF THE TEE FITTING (BOTH SIDES OF TEE).

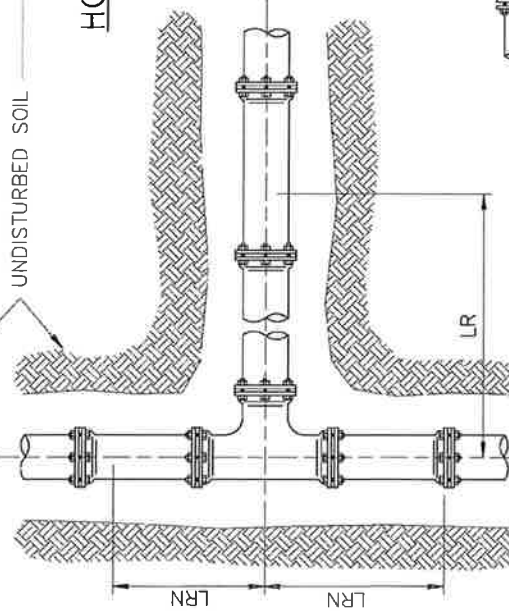

TEES

UNDISTURBED SOIL

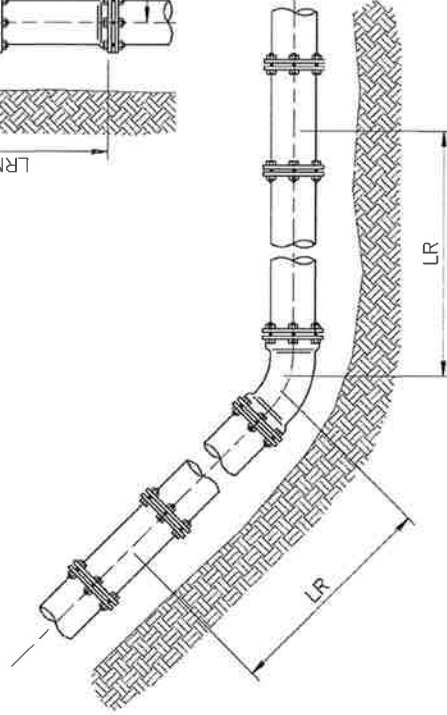

VERTICAL UP BEND

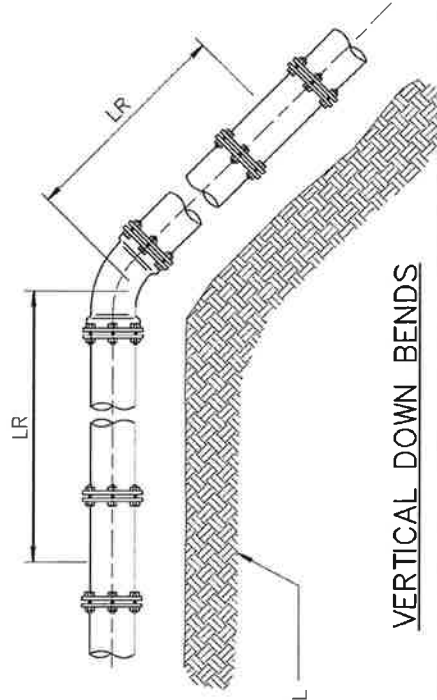

VERTICAL DOWN BENDS

STANDARD SPECIFICATION
FOR THE INSTALLATION OF

JOINT RESTRAINT FOR NEW DUCTILE IRON AND C-900 PVC MAINS

DRAWN BY: CB

APPROVED BY: MW

DATE: 01.16.2007

△

E-9-5-3-1

ARIZONA WATER COMPANY

RESTRAINED LENGTHS, LR, FOR DUCTILE IRON PIPE

NOMINAL PIPE SIZE INCHES	HORIZONTAL BENDS		TEES		VERTICAL OFFSETS						DEAD ENDS
	22-1/2"		LRN=10'		90° BEND FITTINGS		45° BEND FITTINGS		22-1/2" BEND FITTINGS		
	90°	45°	LRN=0°	LRN=10°	DOWN BEND	UP BEND	DOWN BEND	UP BEND	DOWN BEND	UP BEND	
4	18	7	30	8	31	18	13	7	6	3	31
6	25	10	43	20	44	25	18	10	9	5	44
8	32	13	56	34	58	32	24	13	11	6	58
10	38	16	68	45	69	38	29	16	14	8	69
12	45	19	80	57	81	45	34	19	16	9	81
14	51	21	91	68	92	51	38	21	18	10	92
16	57	24	103	79	104	57	43	24	21	11	104
18	62	26	113	90	115	62	48	26	23	12	115
20	68	28	125	100	126	68	52	28	25	14	126
24	79	33	145	121	147	79	61	33	29	16	147

RESTRAINED LENGTHS, LR, FOR DUCTILE IRON PIPE WITH POLYETHYLENE WRAP

NOMINAL PIPE SIZE INCHES	HORIZONTAL BENDS		TEES		VERTICAL OFFSETS						DEAD ENDS
	22-1/2"		LRN=10'		90° BEND FITTINGS		45° BEND FITTINGS		22-1/2" BEND FITTINGS		
	90°	45°	LRN=0°	LRN=10°	DOWN BEND	UP BEND	DOWN BEND	UP BEND	DOWN BEND	UP BEND	
4	26	11	69	18	72	26	30	11	14	5	72
6	36	15	99	47	102	36	42	15	20	7	102
8	47	19	130	78	133	47	55	19	26	9	133
10	56	23	157	103	159	56	66	23	32	11	159
12	65	27	185	131	187	65	77	27	37	13	187
14	74	31	211	156	214	74	89	31	42	15	214
16	82	34	238	183	241	82	100	34	48	16	241
18	90	37	263	207	266	90	110	38	53	18	266
20	98	41	289	233	292	98	121	41	58	20	292
24	113	47	337	280	340	113	141	47	68	22	340

NOTES:

1. ALL JOINTS WITHIN THE SPECIFIED LENGTH LR MUST BE RESTRAINED.
ALL LENGTHS ARE GIVEN IN FEET.
2. THE MAXIMUM TEST PRESSURE SHALL NOT EXCEED 200 PSI
3. THE MINIMUM DEPTH OF BURY SHALL BE 3' TO TOP OF PIPE.
4. RESTRAINED LENGTHS MAY BE REDUCED WHEN SUPPORTED BY ENGINEERING CALCULATIONS.



**STANDARD SPECIFICATION
FOR THE INSTALLATION OF**

JOINT RESTRAINT FOR NEW DUCTILE IRON AND C-900 PVC MAINS

DRAWN BY: CB

APPROVED BY: MW

DATE: 01.16.2007



E-9-5-3-2

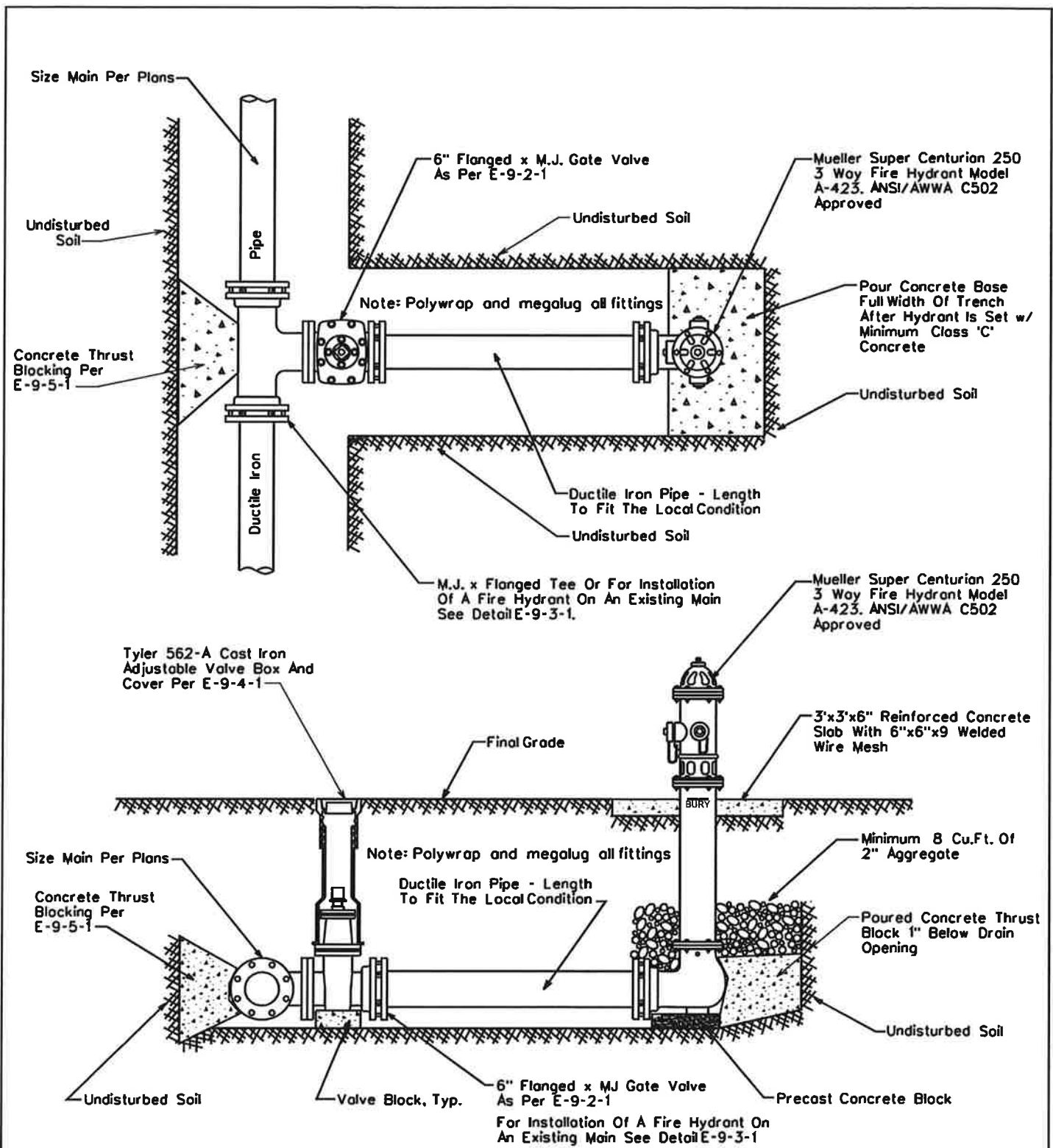

NOTE: All Flanges, Bolts, Nuts and Drain Holes Shall Be Kept Free Of Concrete

ARIZONA WATER COMPANY

STANDARD SPECIFICATION
FOR THE INSTALLATION OF

TYPICAL PERPENDICULAR FIRE HYDRANT

DRAWN BY: CB	APPROVED BY: MW	DATE: 1-28-91	08.24.2006
------------------------	---------------------------	-------------------------	-------------------

E-9-6-1

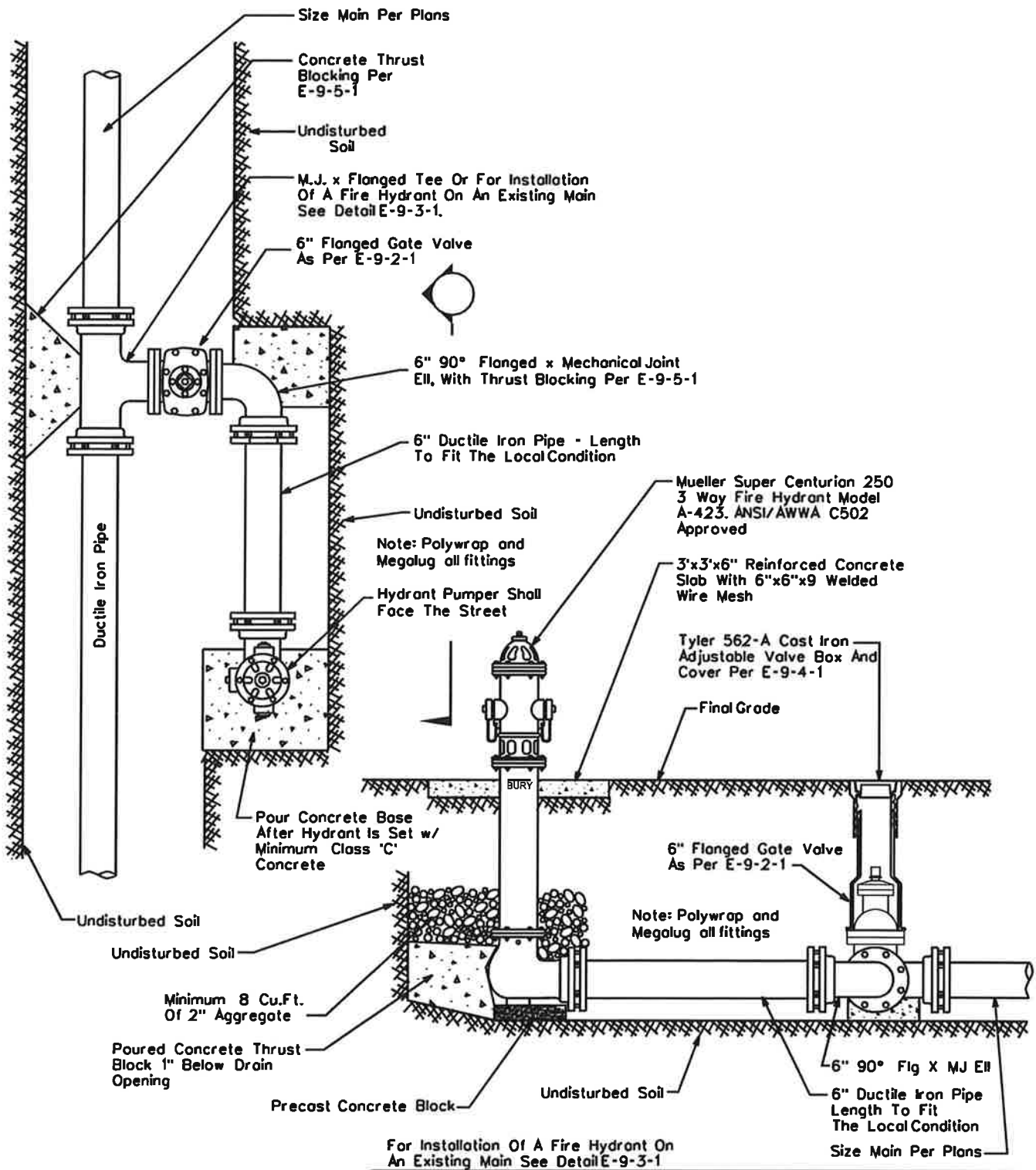

NOTE: All Flanges, Bolts, Nuts And Drain Holes Shall Be Kept Free Of Concrete.

ARIZONA WATER COMPANY

STANDARD SPECIFICATION
FOR THE INSTALLATION OF

TYPICAL PARALLEL FIRE HYDRANT

DRAWN BY: JW	APPROVED BY: MW	DATE: 03.20.1986	08.24.2006
------------------------	---------------------------	----------------------------	-------------------

E-9-7-1

No.4 Meter Box With Lid

Tyler 562-A Valve Box & Cover
w/Notch To Fit Flush Over Valve

2" Sized AB Fill

Final Grade

Minimum Depth Per Arizona Water
Company Standard Specifications

Undisturbed Soil

② ①
③ ②
② ①
④ ③
③ Street Ell

Ductile Iron Pipe
Size Per Plans

Trench Grade

Concrete Thrust Blocking
Per E-9-5-1

12"
30"

⑥	FITTINGS SCHEDULE
1.	2" Mueller 300 Ball Curb Valve B-20283 FIP x FIP w/ 2" Mueller Brass Square Wrench Nut Adapter B-20299
2.	2" Brass Nipple - Length To Fit Field Conditions
3.	2" Brass 90° Elbow, IPST
4.	Mueller Double Strap Bronze Service Saddle - BR2B
5.	M.J. Plug - Megalug Restraints May Be Required
6.	2" Straight Coupling CC x FIP H-15451
7.	2" Copper Pipe
8.	2" Straight Coupling CC x MIP H-1542B
9.	2" Square Head Plug, MIP

ARIZONA WATER COMPANY

STANDARD SPECIFICATION
FOR THE INSTALLATION OF

2" BLOWOFF ASSEMBLY

DRAWN BY: CB	APPROVED BY: MW	DATE: 03.20.1986	△ 03.21.2006	E-9-8-1
-----------------	--------------------	---------------------	--------------	----------------

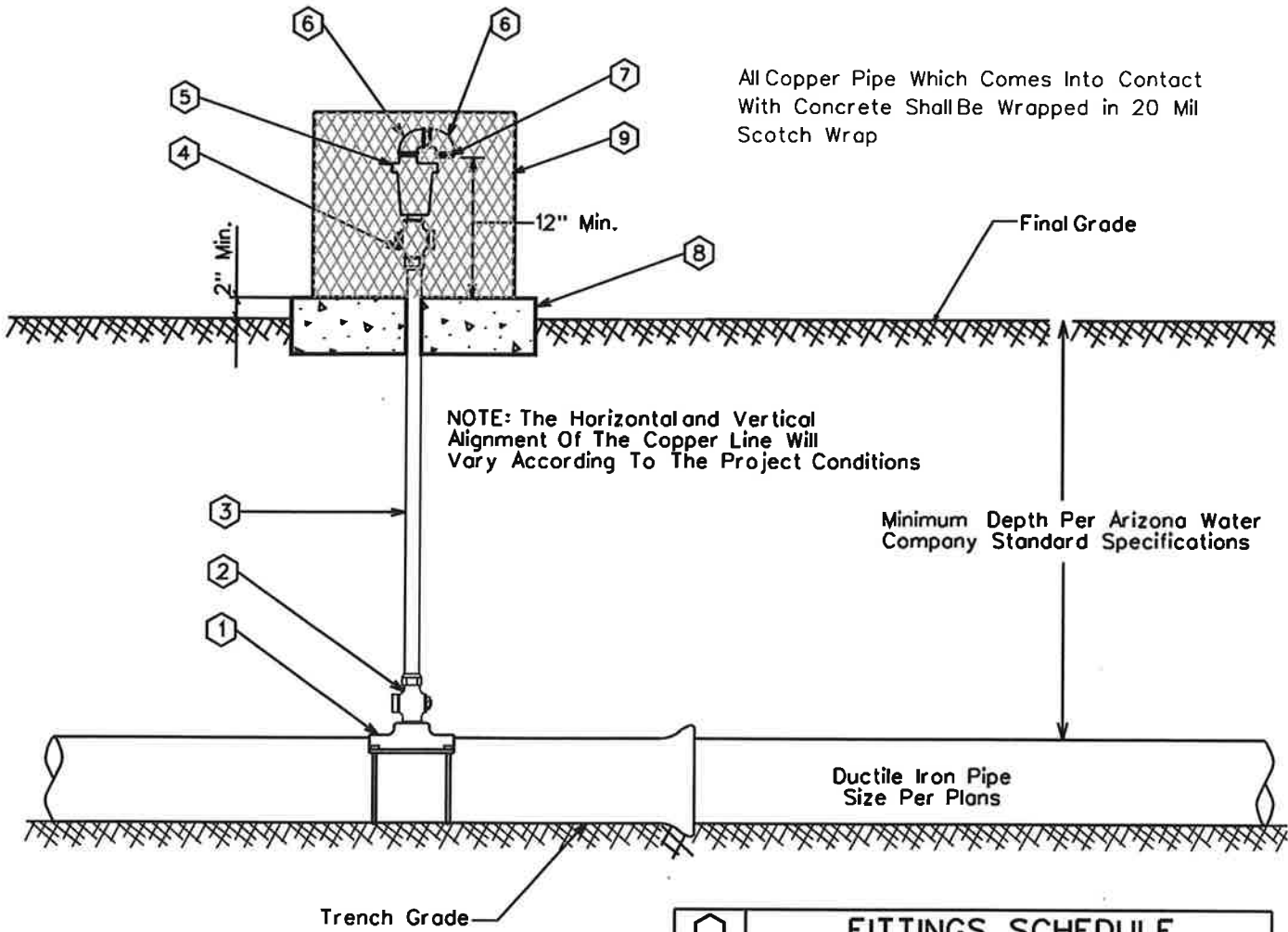

All Copper Pipe Which Comes Into Contact With Concrete Shall Be Wrapped in 20 Mil Scotch Wrap

NOTE: The Horizontal and Vertical Alignment Of The Copper Line Will Vary According To The Project Conditions

Minimum Depth Per Arizona Water Company Standard Specifications

GENERAL NOTES:

1. The valve shall be installed at high points and on long runs to vent the accumulation of air with the line under pressure- see the construction plans for specific locations.
2. The valve shall have a 5/64" orifice with valve sealing faces of stainless steel and BUNA-N rubber.
3. The valve shall be Crispin model AR10 for 6" and larger water mains.
4. Crispin model AR10 valve construction consists of a 1" IPST inlet & 1/2" IPST outlet, cast iron body and top flange with stainless steel float and trim.
5. The air release assembly shall be located out of the path of traffic but within right-of-way or easement.

FITTINGS SCHEDULE	
1.	Mueller BR2B Bronze Service Saddle - Double Strap
2.	1" Mueller B-2500B Taper x Comp. Ball Corp Stop
3.	1" Type 'K' Copper w/NO Splices - Field Fit
4.	1" Mueller B-2502B IP x Comp. Ball Corp Stop
5.	Crispin 1" Air Release Valve, Model AR10
6.	1/2" Brass Street Elbow
7.	No.16 Wire Mesh Screen (Non-Corrodible)
8.	4" Thick Concrete Pad - Class 'C' Concrete
9.	Guardshack, Model GS-1, Available From BPDI, Inc. Available In Leaf Green Or Desert Tan

ARIZONA WATER COMPANY

STANDARD SPECIFICATION FOR THE INSTALLATION OF			
TYPICAL AIR RELEASE VALVE			
DRAWN BY: CB	APPROVED BY: MW	DATE: 03.20.1997	△ 08.24.2006
			E-9-8-2

All Copper Pipe Which Comes Into Contact With Concrete Shall Be Wrapped In 20 Mil Scotch Wrap

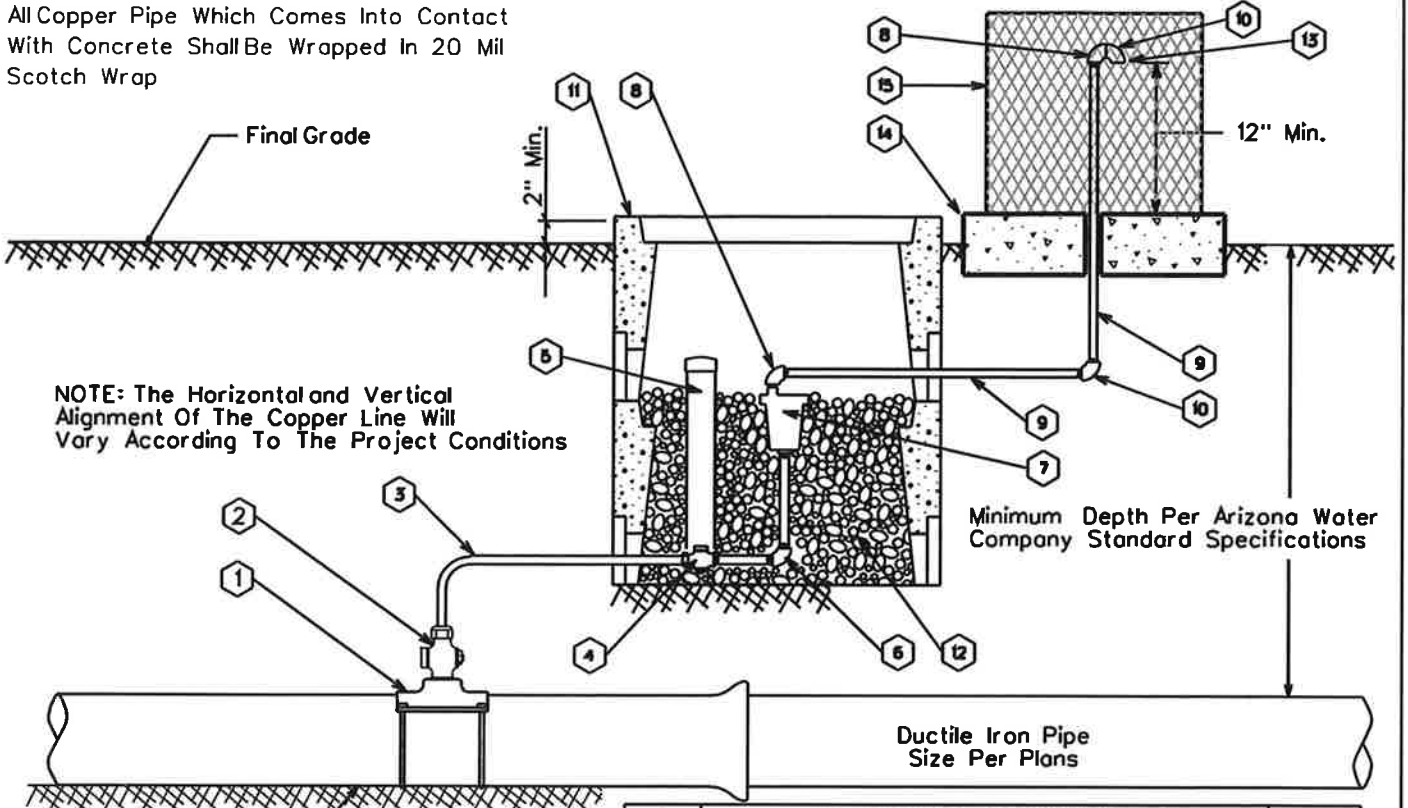

NOTE: The Horizontal and Vertical Alignment Of The Copper Line Will Vary According To The Project Conditions

GENERAL NOTES:

1. The valve shall be installed at high points and on long runs to vent the accumulation of air with the line under pressure- see the construction plans for specific locations.
2. The valve shall have a 3/4" orifice with valve sealing faces of stainless steel and BUNA-N rubber.
3. The valve shall be Crispin model AR10 for 6" and larger water mains.
4. Crispin model AR10 valve construction consists of a 1" IPST inlet & 1/2" IPST outlet, cast iron body and top flange with stainless steel float and trim.
5. The air release assembly shall be located out of the path of traffic but within the right-of-way or easement.

⬡	FITTINGS SCHEDULE	QTY.
1.	Mueller BR2B Bronze Service Saddle - Double Strap	1
2.	1" Mueller B-25008 Taper x Comp. Ball Corp Stop	1
3.	1" Type 'K' Copper w/NO Splices - Field Fit	As Req'd
4.	1" Mueller B-25028 IP x Comp. Ball Corp Stop	1
5.	3" PVC Pipe w/ Cap (Loose Fit)	1
6.	1" x 4" Brass Nipple w/90° Elbow	1
7.	Crispin 1" Air Release Valve, Model AR10	1
8.	1/2" Brass Street Elbow	2
9.	1/2" Galvanized Pipe - Length as req'd	2
10.	1/2" Galvanized 90° Ell	2
11.	Number 1 Meter Box	2
12.	2" Sized AB (Fill Meter Box To The Top Of The Air Release Valve)	As Req'd
13.	No.16 Wire Mesh Screen (Non-Corrodible)	1
14.	4" Thick Concrete Pad - Class 'C' Concrete	1
15.	Guardshack, Model GS-1, Available From BPD, Inc. Available In Leaf Green Or Desert Tan	1

ARIZONA WATER COMPANY

STANDARD SPECIFICATION FOR THE INSTALLATION OF				
AIR RELEASE VALVE FOR THE NORTHERN REGION				
DRAWN BY:	CB	APPROVED BY:	MW	DATE:
				03.20.1997 △ 08.24.2006
				E-9-8-3

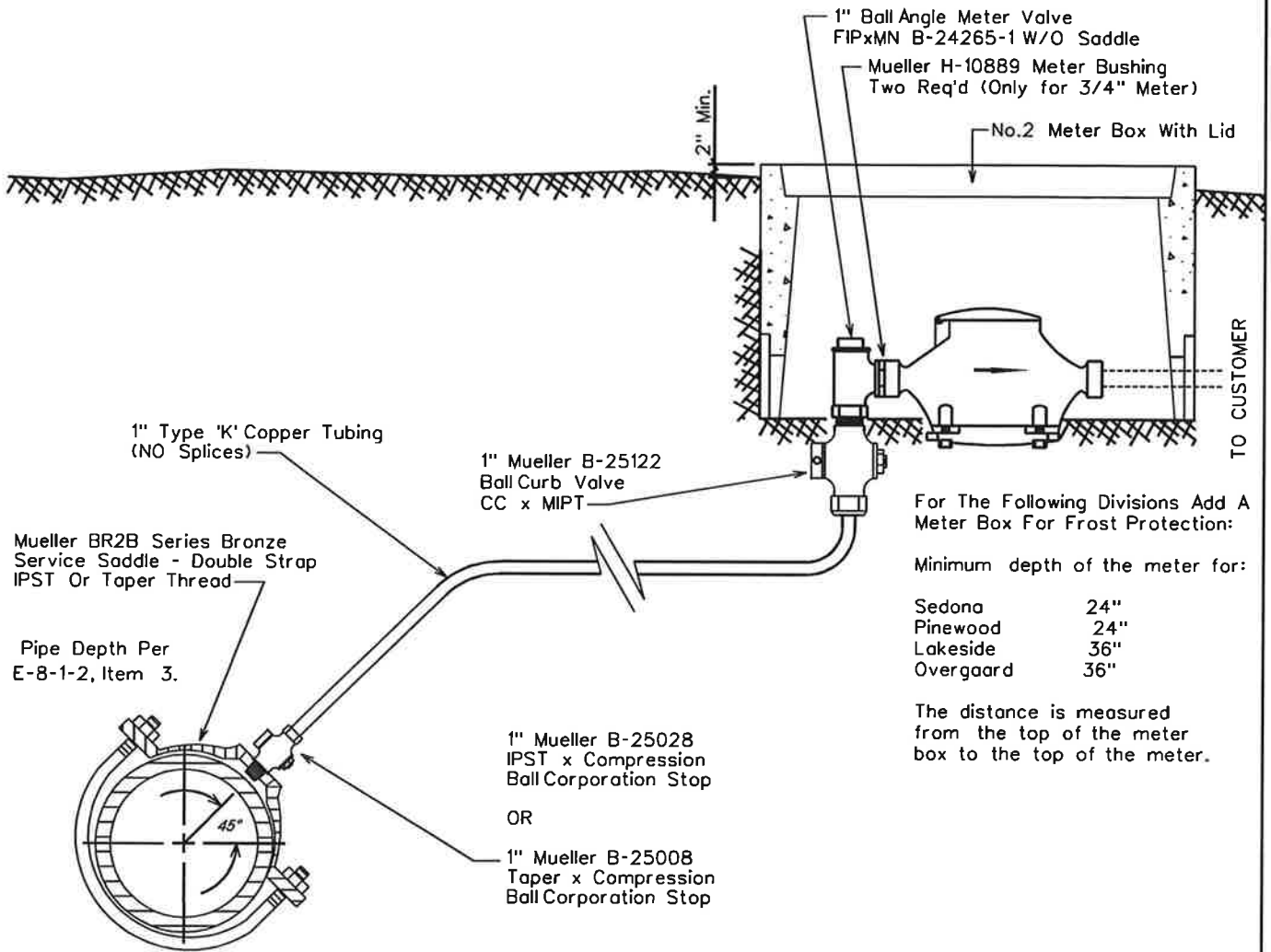

SADDLE TAP TO CA, PVC, OR DI PIPE

NOTE: The minimum distance between taps on mains other than ductile iron is 12"

NOTE:
Only the meter is supplied by
Arizona Water Company



STANDARD SPECIFICATION FOR THE INSTALLATION OF				
SINGLE SERVICE CONNECTION FOR A 3/4" OR 1" METER				
DRAWN BY:	CCO	APPROVED BY:	M.W.	DATE:
				3/20/86
				△ 03.17.2006
				E-9-9-1

For The Following Divisions Add A
Meter Box For Frost Protection:

Minimum depth of the meter for:

Sedona	24"
Pinewood	24"
Lakeside	36"
Overgard	36"

The distance is measured from the top of the meter box to the top of the meter.

No.2 Meter Box With Lid
Mueller H-10889 Meter Bushing
Two Req'd Per Meter

See note for the minimum depth requirements for frost protection

1" Ball Angle Meter Valve
B-24265-1 FIPxMTR
W/O Saddle

1" Ball Straight Meter Valve
B-25170 CCxFIP
(To allow for meter valve replacement)

1"x 1"x 13.5" Straight U-Branch
Mueller H-15364
MIP Inlet x MIP Outlet

1" Brass 90° Street Ell

Mueller BR2B Series Bronze
Service Saddle - Double Strap
IPST Or Taper Thread

Pipe Depth Per
E-8-1-2, Item 3.

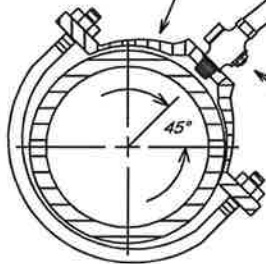

1" Type 'K' Copper Tubing
(NO Splices)

1" Mueller B-25028
IPST x Compression
Ball Corporation Stop

OR

1" Mueller B-25008
Taper x Compression
Ball Corporation Stop

SADDLE TAP TO CA, PVC,
OR DI PIPE

NOTE: The minimum distance between
service taps on mains other than ductile
iron is 12"

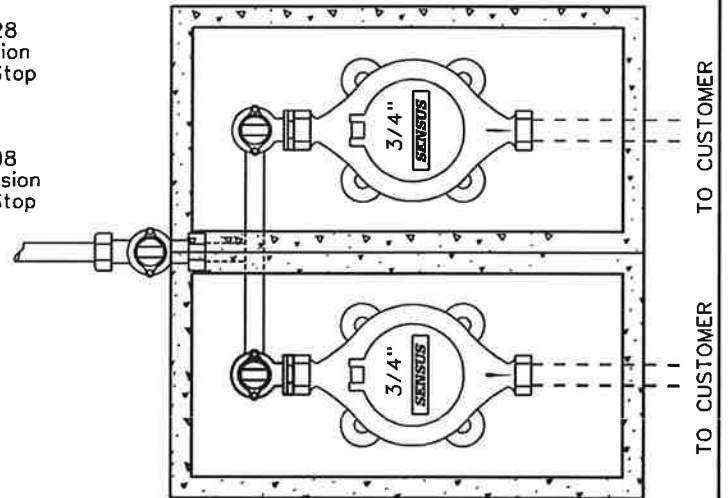

NOTE:
Only the meter is supplied by
Arizona Water Company

ARIZONA WATER COMPANY

STANDARD SPECIFICATION
FOR THE INSTALLATION OF

DOUBLE SERVICE CONNECTION FOR 3/4" METERS

DRAWN BY:	CCO	APPROVED BY:	M.W.	DATE:	3-20-86	△ 08.25.2006	E-9-10-1
-----------	-----	--------------	------	-------	---------	--------------	-----------------

For The Following Divisions Add A Meter Box For Frost Protection:

Minimum depth of the meter for:

Sedona	24"
Pinewood	24"
Lakeside	36"
Overgaard	36"

The distance is measured from the top of the meter box to the top of the meter.

Mueller BR2B Series Bronze Service Saddle - Double Strap IPST Or Taper Thread

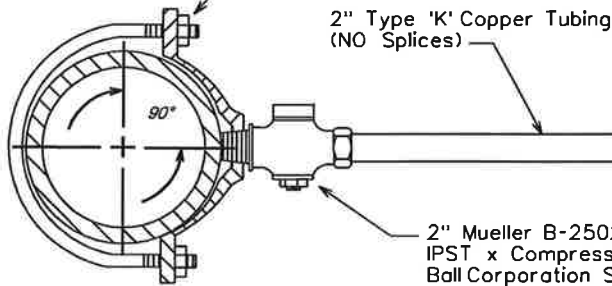

Pipe Depth Per E-8-1-2, Item 3.

No.2 Meter Box With Lid

1" Ball Angle Meter Valve B-24265-1 FIPxMTR W/O Saddle

2" Mueller Ball Curb Valve B-25172 CCxFIP (To allow for meter valve replacement)

2" Mueller B-25028 IPST x Compression Ball Corporation Stop

OR

2" Mueller B-25008 Taper x Compression Ball Corporation Stop

See note for the minimum depth requirements for frost protection

1"x 1"x 13.5" Straight U-Branch Mueller H-15364 MIP Inlet x MIP Outlet

1" Brass 90° Street El

Mueller 47164 Brass Bushing 2" MIP x 1" FIP

TO CUSTOMER

TO CUSTOMER

TO CUSTOMER

SADDLE TAP TO CA, PVC, OR DI PIPE

NOTE: The minimum distance between service taps on mains other than ductile iron is 12"

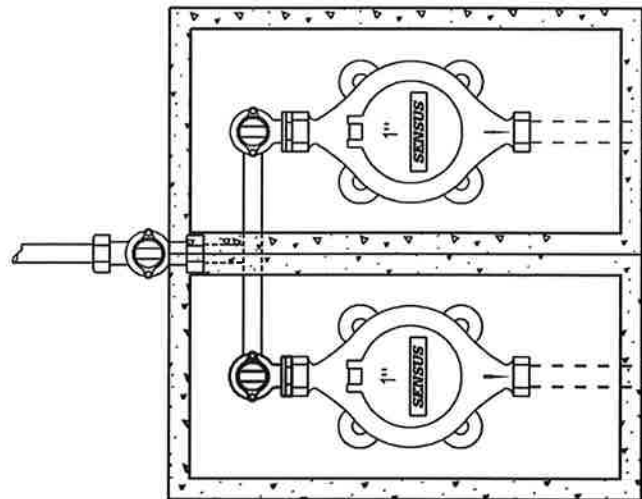

NOTE: THE LENGTH OF SERVICE IS LIMITED TO COMMERCIALY AVAILABLE ROLLS, TYPICALLY 60 FEET

NOTE: Only the meter is supplied by Arizona Water Company



STANDARD SPECIFICATION FOR THE INSTALLATION OF

DOUBLE SERVICE CONNECTION FOR 1" METERS

DRAWN BY: CB	APPROVED BY: M.W.	DATE: 03.17.2006	08.29.2006	E-9-10-2
--------------	-------------------	------------------	------------	----------

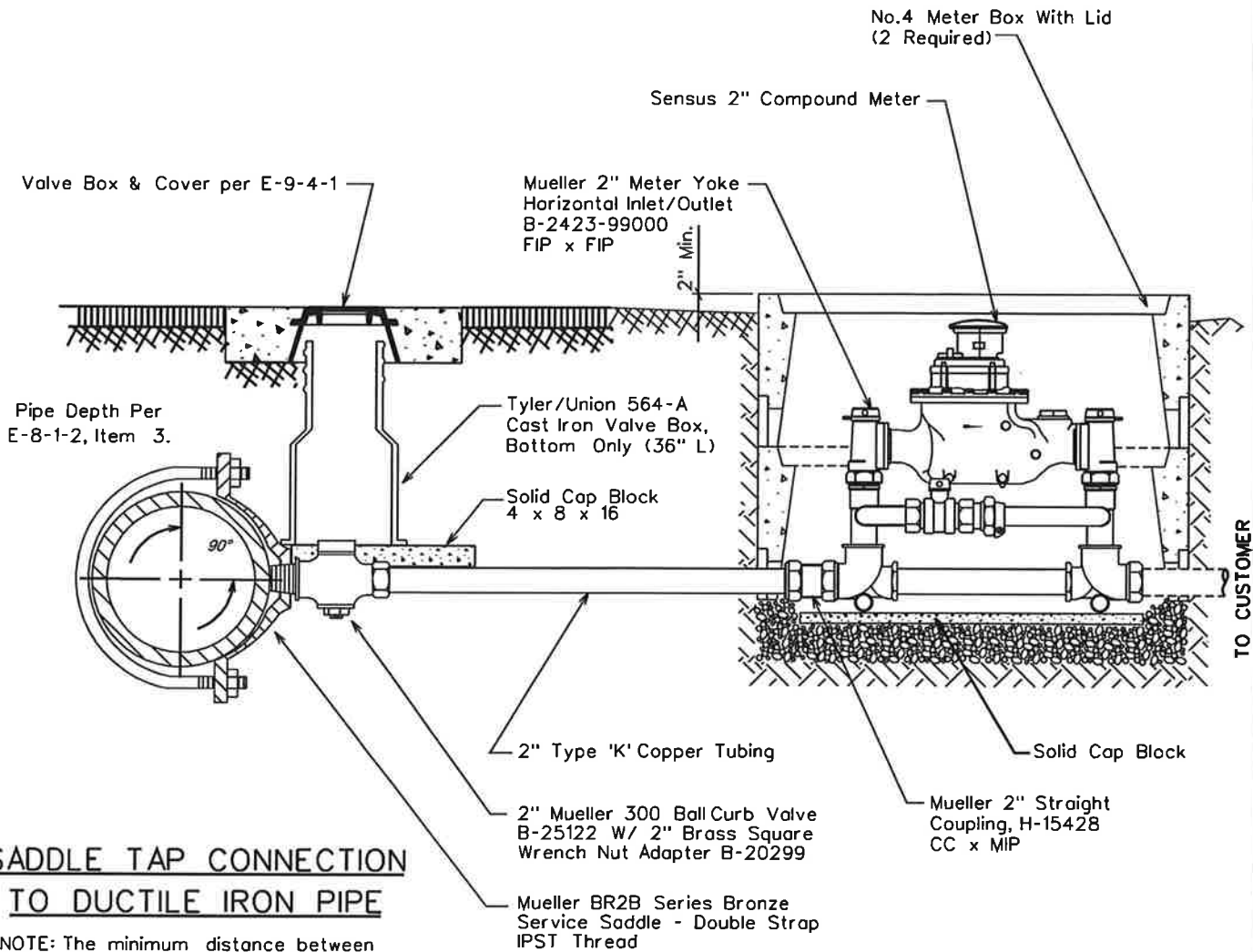

**SADDLE TAP CONNECTION
TO DUCTILE IRON PIPE**

NOTE: The minimum distance between service taps on mains other than ductile iron is 12"

NOTE: THE LENGTH OF SERVICE IS LIMITED TO COMMERCIALY AVAILABLE ROLLS, TYPICALLY 60 FEET

NOTE:
Only the meter is supplied by Arizona Water Company



STANDARD SPECIFICATION FOR THE INSTALLATION OF				
TYPICAL 2" SERVICE CONNECTIONS				
DRAWN BY:	APPROVED BY:	DATE:	△	E-9-11-1
JW	M.W.	3/20/86	△	08.29.2006

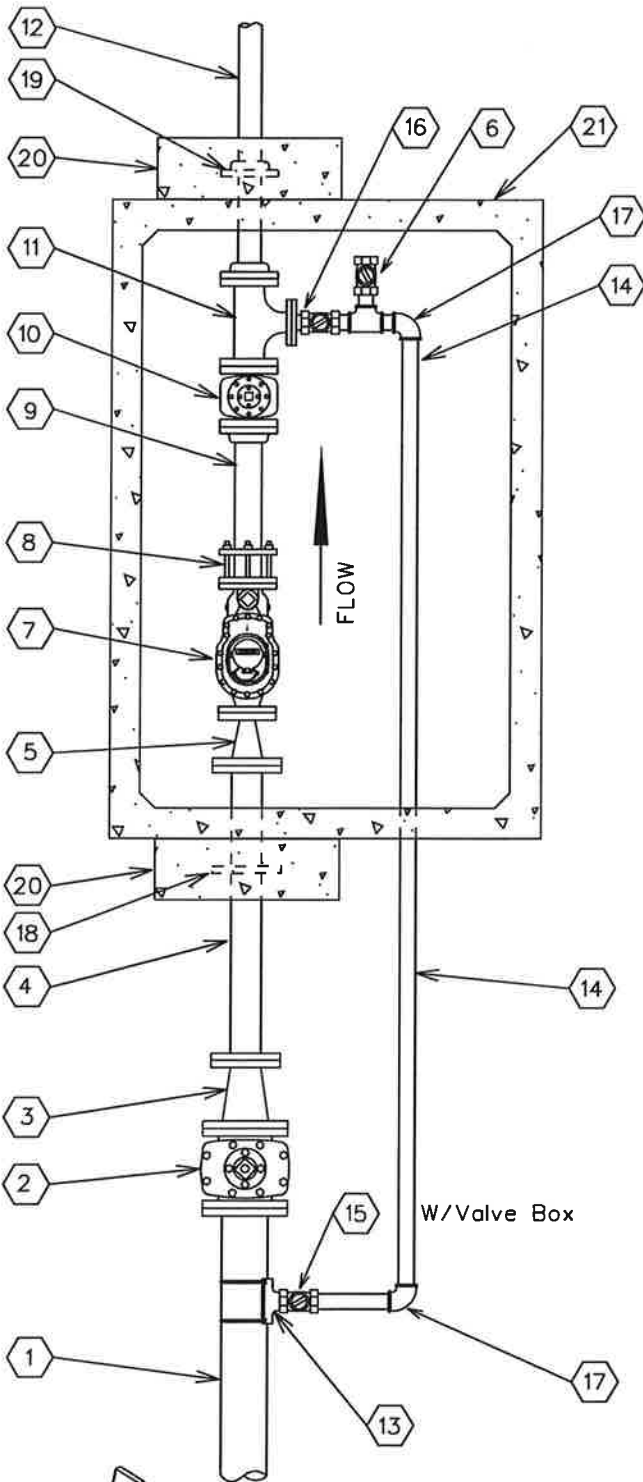

No.	FITTINGS SCHEDULE
1.	6" D.I.P.
2.	6" G.V.B.&C. mj x flng
3.	6"x4" Reducer flng x mj
4.	4"x3'-0" D.I.P. Spool flng x pe
5.	4" x 3" Reducer flng
6.	2" Test Port
7.	3" Compound Meter
8.	3" F.C.A.
9.	3"x2'-0" D.I. Spool flng x pe
10.	3" Gate Valve flng
11.	3"x2" Flg Tee w/ 2" Companion Flange
12.	3"x4'-0" D.I. Spool flng x pe
13.	6"x2" Tapping Saddle
14.	2" Copper Pipe
15.	2" Mueller B25122 Ball Valve w/B20299 Nut
16.	2" Locking Ball Valve (normally closed)
17.	2" Mueller H-15526 90° Ell CC x CC
18.	4" Megalug
19.	3" Slip-On Welding Flange
20.	24"x24"x8" Conc. Thrust Block P.I.P.
21.	575-LA Conc. Vault

NOTE:

1. Use Rowley pipe supports or equivalent as needed (See detail below).
2. Pipe support locations to be determined by field personnel.
3. All copper pipe that comes in contact with concrete to be wrapped w/10-20 Mil. Scotchwrap corrosion protection tape.
4. All mechanical joint fittings are to be megalugged.
5. Use deflection fittings (45° Ells.) to achieve necessary depths & cover as shown on the standard specification for the installation of a concrete vault (E-9-12-5).

ARIZONA WATER COMPANY

**STANDARD SPECIFICATION
FOR THE INSTALLATION OF**

3" COMPOUND METER

DRAWN BY: CCO	APPROVED BY: MW	DATE: 10/5/1993	△08.29.2006	E-9-12-1
------------------	--------------------	--------------------	-------------	----------

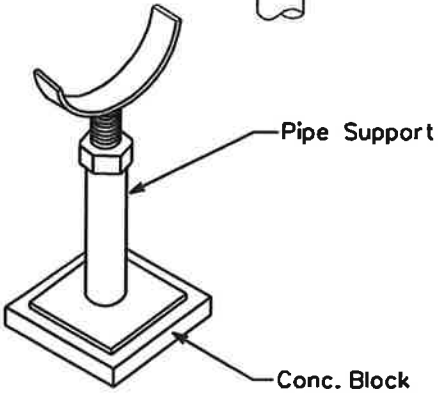

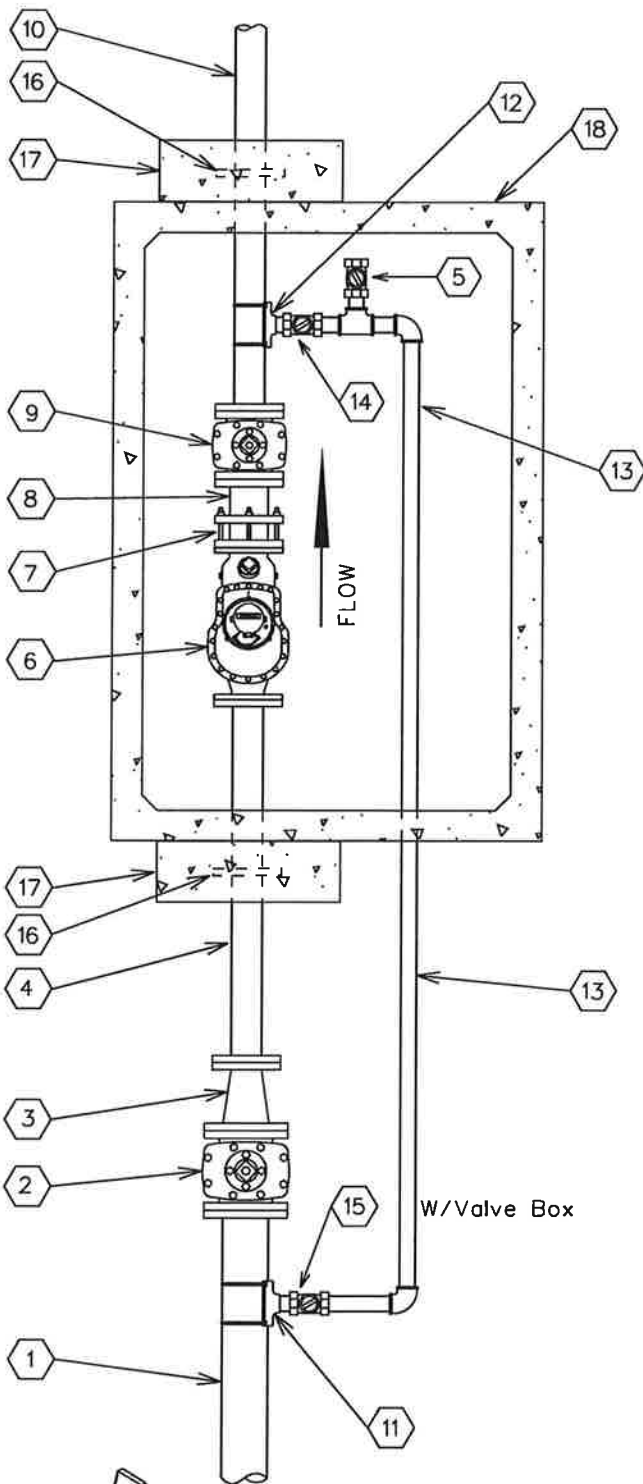

No.	FITTINGS SCHEDULE
1.	6" D.I.P.
2.	6" G.V.B.&C. mj x flng
3.	6"x4" Reducer flng x mj
4.	4"x3'-0" D.I.P. Spool flng x pe
5.	2" Test Port
6.	4" Compound Meter
7.	4" F.C.A.
8.	4"x1'-0" D.I.P. Spool flng x pe
9.	4" Gate Valve flng
10.	4"x4'-0" D.I.P. Spool flng x pe
11.	6"x2" Tapping Saddle
12.	4"x2" Tapping Saddle
13.	2" Copper Pipe
14.	2" Ball Valve / Locking (Normally Closed)
15.	2" Mueller B25122 Ball Valve w/B20299 Nut
16.	4" Megalug
17.	24"x24"x8" Conc. Thrust Block P.I.P.
18.	575-LA Conc. Vault

NOTE:

1. Use Rowley pipe supports or equivalent as needed (See detail below).
2. Pipe support locations to be determined by field personnel.
3. All copper pipe that comes in contact with concrete to be wrapped w/10-20 Mil. Scotchwrap corrosion protection tape.
4. All mechanical joint fittings are to be megalugged.
5. Use deflection fittings (45° Ells.) to achieve necessary depths & cover as shown on the standard specification for the installation of a concrete vault (E-9-12-5).

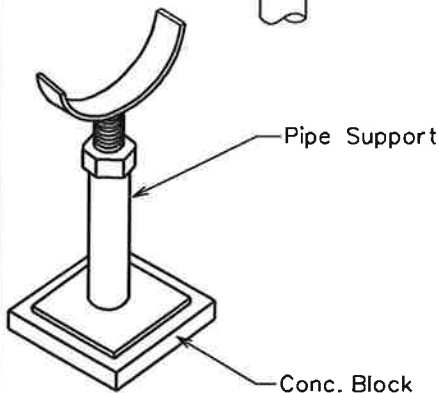

ARIZONA WATER COMPANY

**STANDARD SPECIFICATION
FOR THE INSTALLATION OF**

4" COMPOUND METER

DRAWN BY:	APPROVED BY:	DATE:		
CCO	MW	10/5/1993	△08.29.2006	E-9-12-2

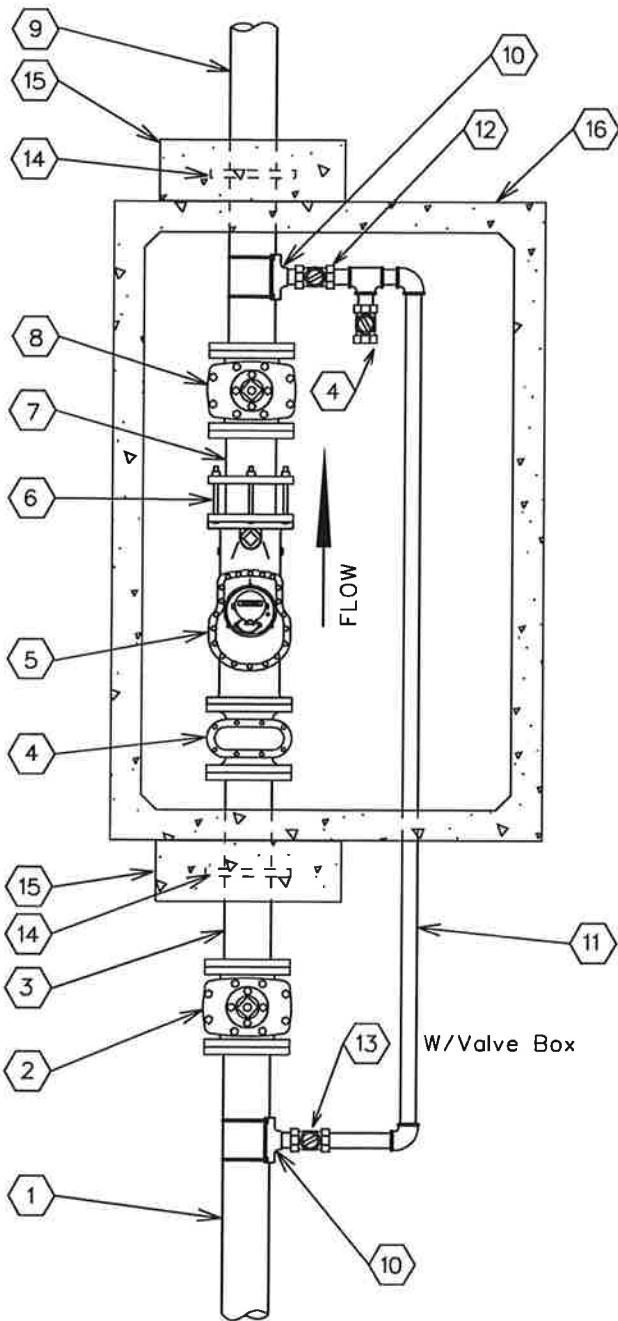

No.	FITTINGS SCHEDULE
1.	6" D.I.P.
2.	6" G.V.B.&C. mj
3.	6"x 3'-0" D.I.P. Spool flng x pe
4.	2" Test Port
5.	6" Compound Meter
6.	6" F.C.A.
7.	6"x 1'-0" D.I.P. Spool flng x pe
8.	6" Gate Valve flng
9.	6"x 4'-0" D.I.P. Spool flng x pe
10.	6"x2" Tapping Saddle
11.	2" Copper Pipe
12.	2" Ball Valve / Locking (Normally Closed)
13.	2" Mueller B25122 Ball Valve w/B20299 Nut
14.	6" Megalug
15.	24"x24"x8" Conc. Thrust Block P.I.P.
16.	575-LA Conc. Vault

NOTE:

1. Use Rowley pipe supports or equivalent as needed (See detail below).
2. Pipe support locations to be determined by field personnel.
3. All copper pipe that comes in contact with concrete to be wrapped w/10-20 Mil. Scotchwrap corrosion protection tape.
4. All mechanical joint fittings are to be megalugged.
5. Use deflection fittings (45° Ells.) to achieve necessary depths & cover as shown on the standard specification for the installation of a concrete vault (E-9-12-5).

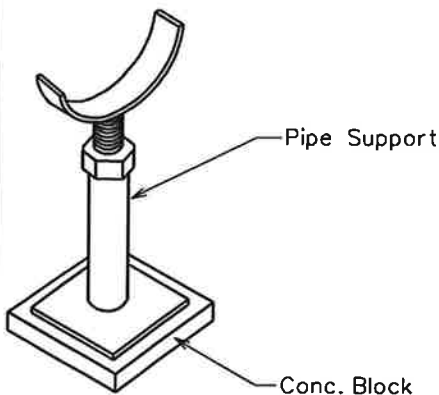

ARIZONA WATER COMPANY

STANDARD SPECIFICATION FOR THE INSTALLATION OF

6" COMPOUND METER

DRAWN BY: CCO	APPROVED BY: MW	DATE: 10/5/1993	△08.29.2006	E-9-12-3
------------------	--------------------	--------------------	-------------	----------

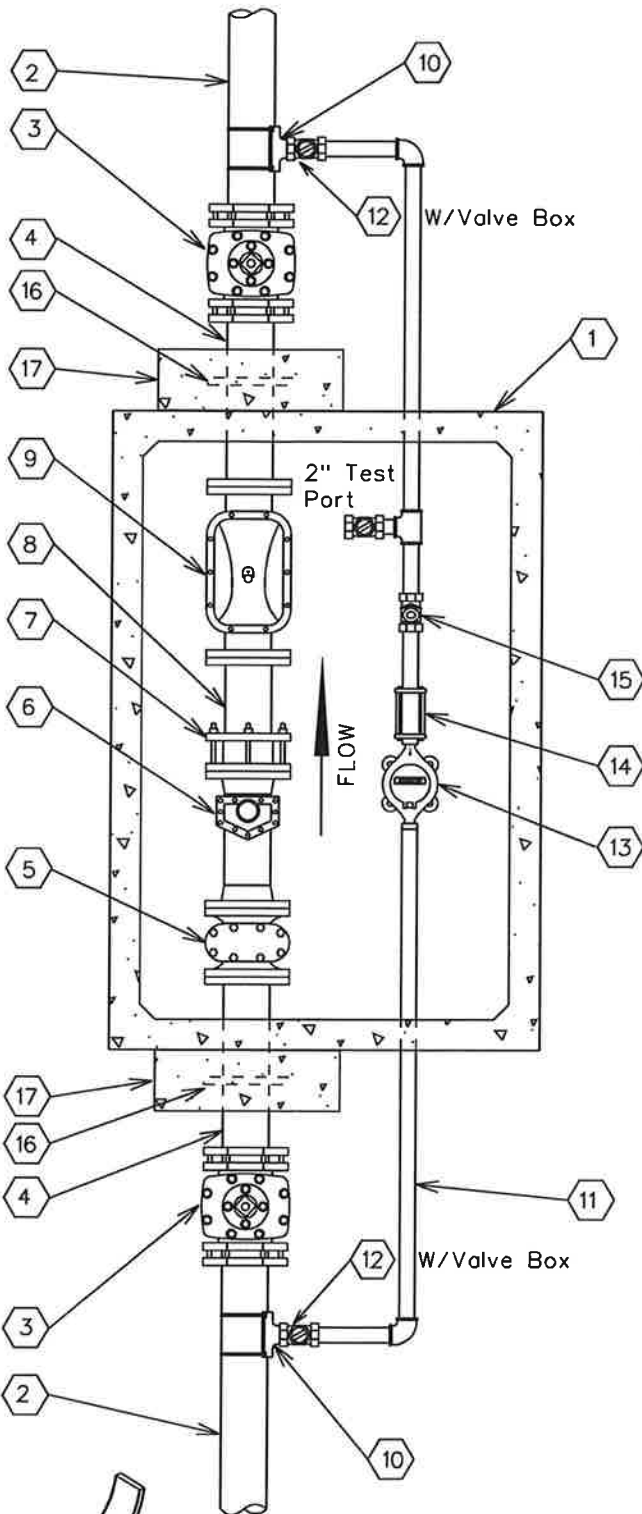

No.	FITTINGS SCHEDULE
1.	575-LA Conc. Vault
2.	6" D.I.P.
3.	6" G.V.B.&C. m.j.
4.	6" x 3'-0" D.I.P. Spool Piece flng x pe
5.	6" Strainer
6.	6" Turbo Meter
7.	6" F.C.A.
8.	6" x 2'-0" D.I.P. Spool Piece flng x pe (TRIM SPOOL PIECE TO 3x THE PIPE DIA.)
9.	6" Detector Check
10.	6"x*N" Tapping Saddle
11.	*N" Copper Pipe
12.	*N" Ball Valve (Locking)
13.	*N" Meter
14.	*N" Coup. Adapt.
15.	*N" Flapper Check Valve
16.	6" Megalug
17.	24"x24"x8" Conc. Thrust Block P.I.P.

*N - Size To Be determined By A.W.Co.

NOTE:

1. Use Rowley pipe supports or equivalent as needed (See detail below).
2. Pipe support locations to be determined by field personnel.
3. All copper pipe that comes in contact with concrete to be wrapped w/10-20 Mil. Scotchwrap corrosion protection tape.
4. All mechanical joint fittings are to be megalugged.
5. Use deflection fittings (45° Ells.) to achieve necessary depths & cover as shown on the standard specification for the installation of a concrete vault (E-9-12-5).
6. To change from a 6" service to a 4" service, change all listed 6" materials to 4" materials.

ARIZONA WATER COMPANY

STANDARD SPECIFICATION FOR THE INSTALLATION OF

6" COMPOUND SERVICE

DRAWN BY:

CCO

APPROVED BY:

MW

DATE:

10/05/1993

△08.29.2006

E-9-12-4

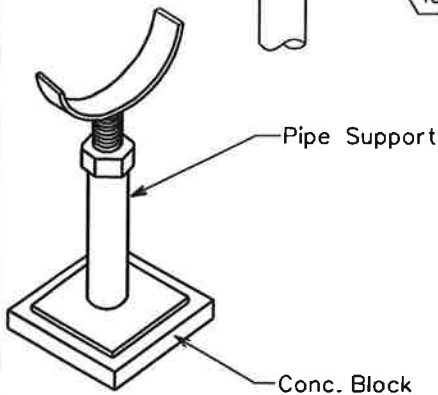

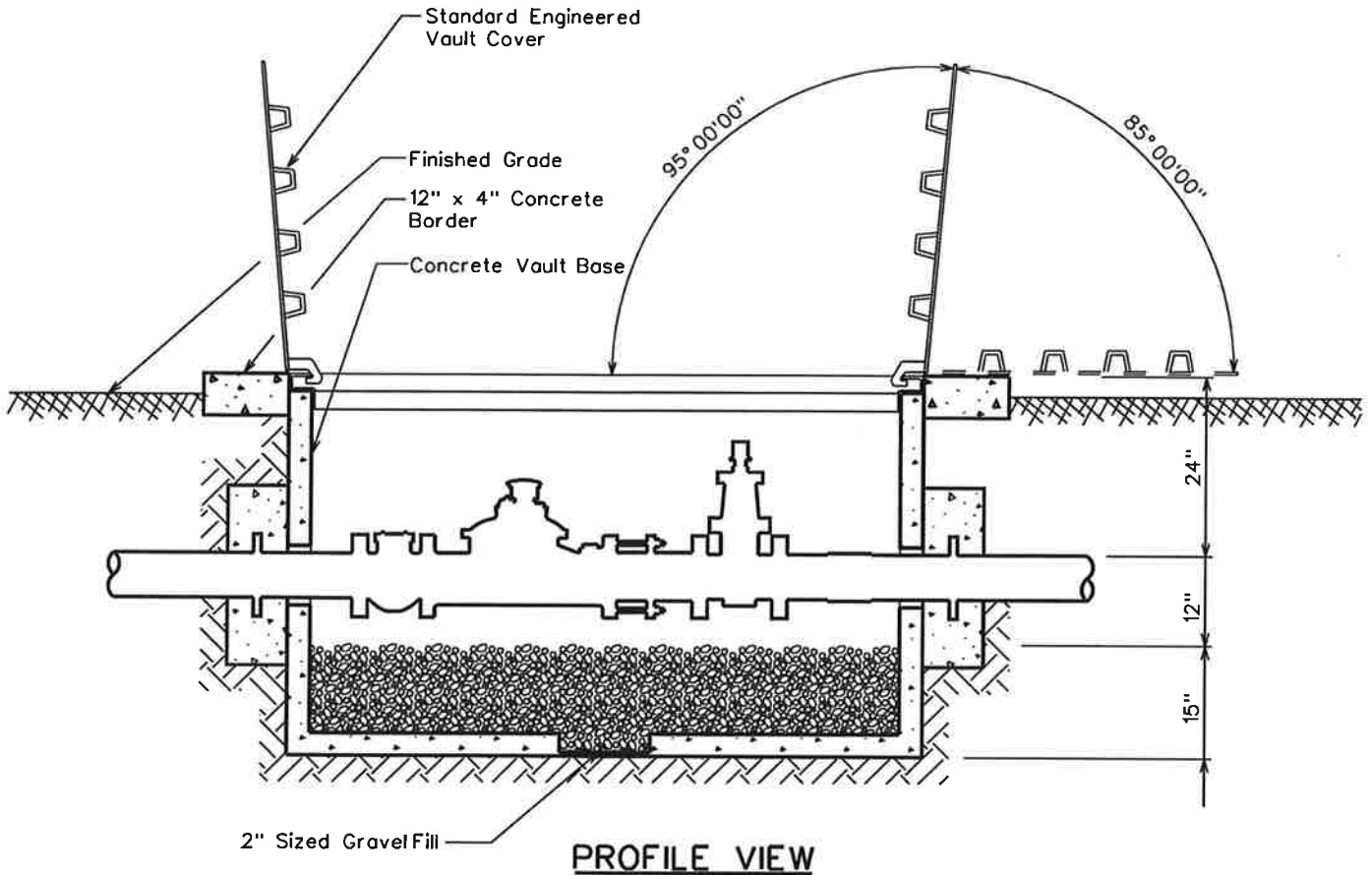

CONCRETE VAULT & COVER SPECIFICATIONS

- Vault - Base No. 575-BL
- Cover - Standard Engineered Vault Cover
- . 4874 Aluminum Diamond Plate Cover For Non-Traffic Loading Areas
- Or
- . 4874 Galvanized Steel Diamond Plate Cover W/ H-20 Traffic Loading
- . Double Torsion Spring Assisted Doors W/ Recessed Hasp & Safety Latches

NOTES

1. Total Depth Of Concrete Vault To Be A Maximum Of 3'-0" From Top Of Vault Cover To Top Of Gravel Fill.
2. Service Connections Larger Than 6" In Diameter Will Conform To The Same Vault & Cover Specifications. Size Of Vault & Cover To Be Determined By A.W.Co. Engineers.

ARIZONA WATER COMPANY

STANDARD SPECIFICATION
FOR THE INSTALLATION OF

CONCRETE VAULT

DRAWN BY: CCO	APPROVED BY: MW	DATE: 10/5/1993	△ 05.17.2001	E-9-12-5
------------------	--------------------	--------------------	--------------	-----------------

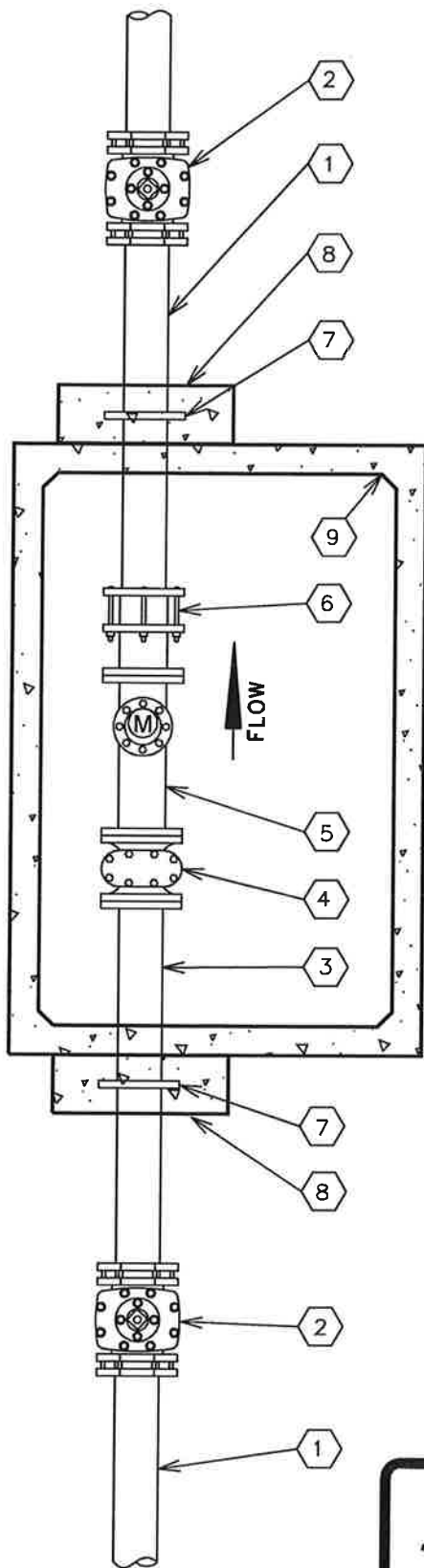

No.	FITTINGS SCHEDULE
1.	Ductile Iron Pipe
2.	Gate Valve M.J.
3.	D.I.P. Spool Piece Flg x Pe (10xDia.)
4.	Meter Strainer
5.	Propeller Meter
6.	Flanged Coupling Adapter
7.	Megalug Gland (Thrust Anchor)
8.	Concrete Thrust Block P.I.P.
9.	Concrete Vault

NOTE:

1. Use Rowley pipe supports or equivalent as needed (See E-9-12-4).
2. Pipe support locations to be determined by field personnel.
3. All Sched. 40 Stl. pipe outside of vault to be wrapped w/10-20 Mil. Scotchwrap corrosion protection tape.
4. All mechanical joint fittings to are to be megalugged.
5. Use deflection fittings (45° Ells.) to achieve necessary depths & cover as shown on the standard specification for the installation of a concrete vault (E-9-12-5).

ARIZONA WATER COMPANY

STANDARD SPECIFICATION FOR THE INSTALLATION OF			
NON-POTABLE PROPELLER METER			
DRAWN BY: JPK	APPROVED BY: MW	DATE: 7-20-95	△
			E-9-12-6

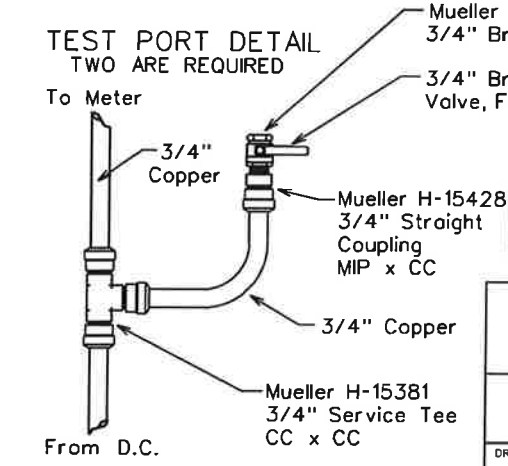
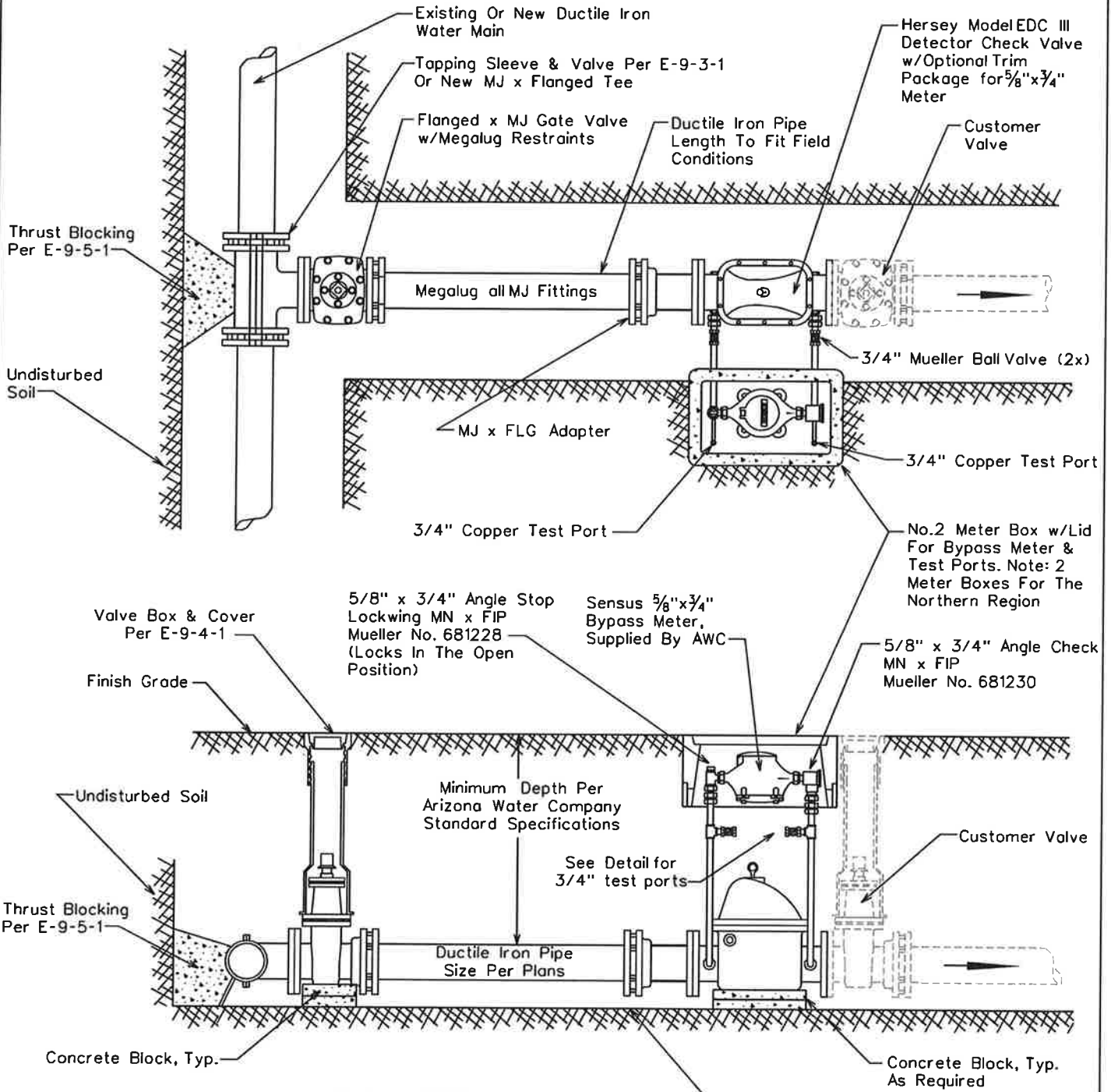

ARIZONA WATER COMPANY

**STANDARD SPECIFICATION
FOR THE INSTALLATION OF**

TYPICAL 4" THRU 8" DETECTOR CHECK VALVES

DRAWN BY: CB	APPROVED BY: MW	DATE: 10.16.1990	△ 03.09.2007
			E-9-13-1

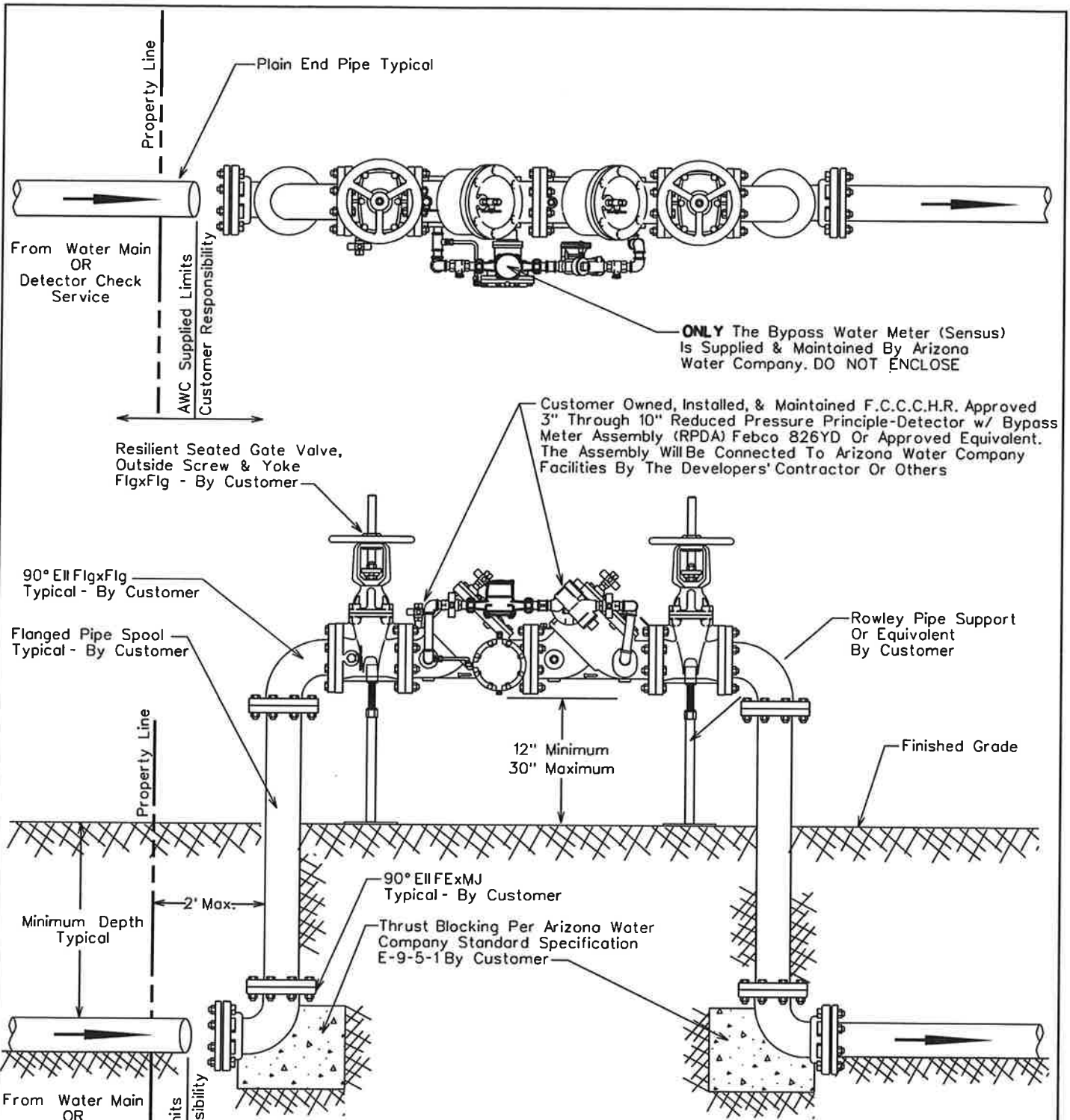

NOTE:

Minimum Depth Of Cover Over 6" & 8" Mains is 36 Inches, 12" & Greater is 48 Inches Unless Otherwise Specified

ARIZONA WATER COMPANY

STANDARD SPECIFICATION			
FOR THE INSTALLATION OF			
3" THRU 10" REDUCED PRESSURE PRINCIPLE-DETECTOR WITH BYPASS METER ASSEMBLY (RPDA) FOR FIRELINE SERVICES			
DRAWN BY: CB	APPROVED BY: MW	DATE: 10-13-98	△ 1-19-2000
			E-9-13-2

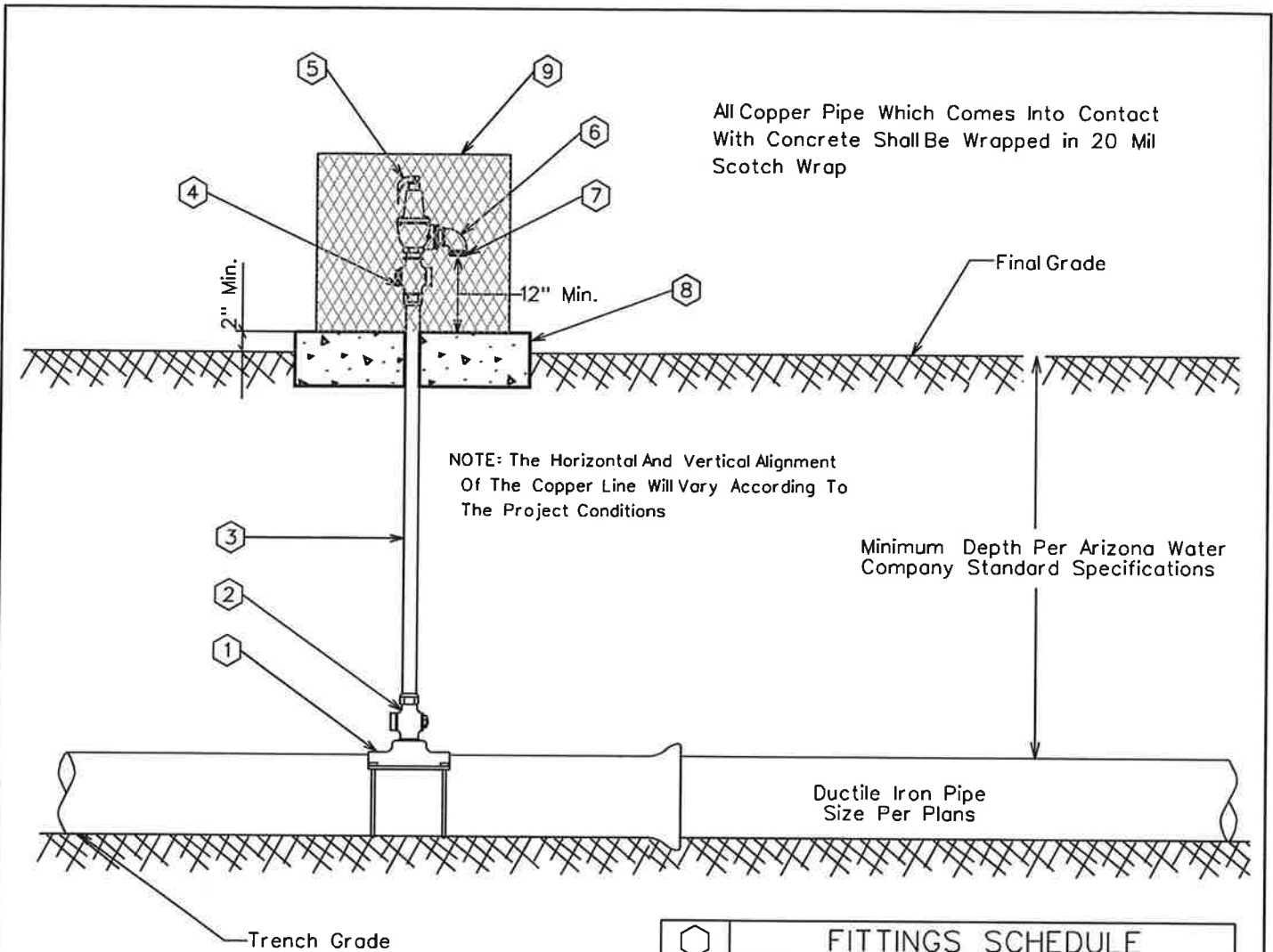

All Copper Pipe Which Comes Into Contact With Concrete Shall Be Wrapped in 20 Mil Scotch Wrap

NOTE: The Horizontal And Vertical Alignment Of The Copper Line Will Vary According To The Project Conditions

Minimum Depth Per Arizona Water Company Standard Specifications

Ductile Iron Pipe
Size Per Plans

Trench Grade

NOTE:

1. Pressure relief valves are typically located just down stream of a pressure reducing station or where system conditions might be subject to greater than allowable pressures.
2. The relief valve assembly and vandal enclosure shall be located out of the roadway, but within the right-of-way or easement.

FITTINGS SCHEDULE	
1.	Mueller BR2B Bronze Service Saddle - Double Strap
2.	2" Mueller B-2500B Taper x Comp. Ball Corp Stop
3.	2" Type 'K' Copper w/NO Splices - Field Fit
4.	2" Mueller B-2502B IP x Comp. Ball Corp Stop
5.	2" Pressure Relief Valve Watts 174A With A 2" Inlet / 2" Outlet 30-150 psi W/ Bronze Body
6.	2" Brass Street Elbow
7.	No.16 Wire Mesh Screen (Non-Corrodible)
8.	4" Thick Concrete Pad - Class 'C' Concrete
9.	Vandal enclosure to be centered on the concrete pad

ARIZONA WATER COMPANY

STANDARD SPECIFICATION
FOR THE INSTALLATION OF

TYPICAL PRESSURE RELIEF VALVE ASSEMBLY

DRAWN BY: CCO	APPROVED BY: MW	DATE: 3/20/1986	△ 08.29.2006	E-9-14-1
------------------	--------------------	--------------------	--------------	----------

All Copper Pipe Which Comes Into Contact With Concrete Shall Be Wrapped in 20 Mil Scotch Wrap

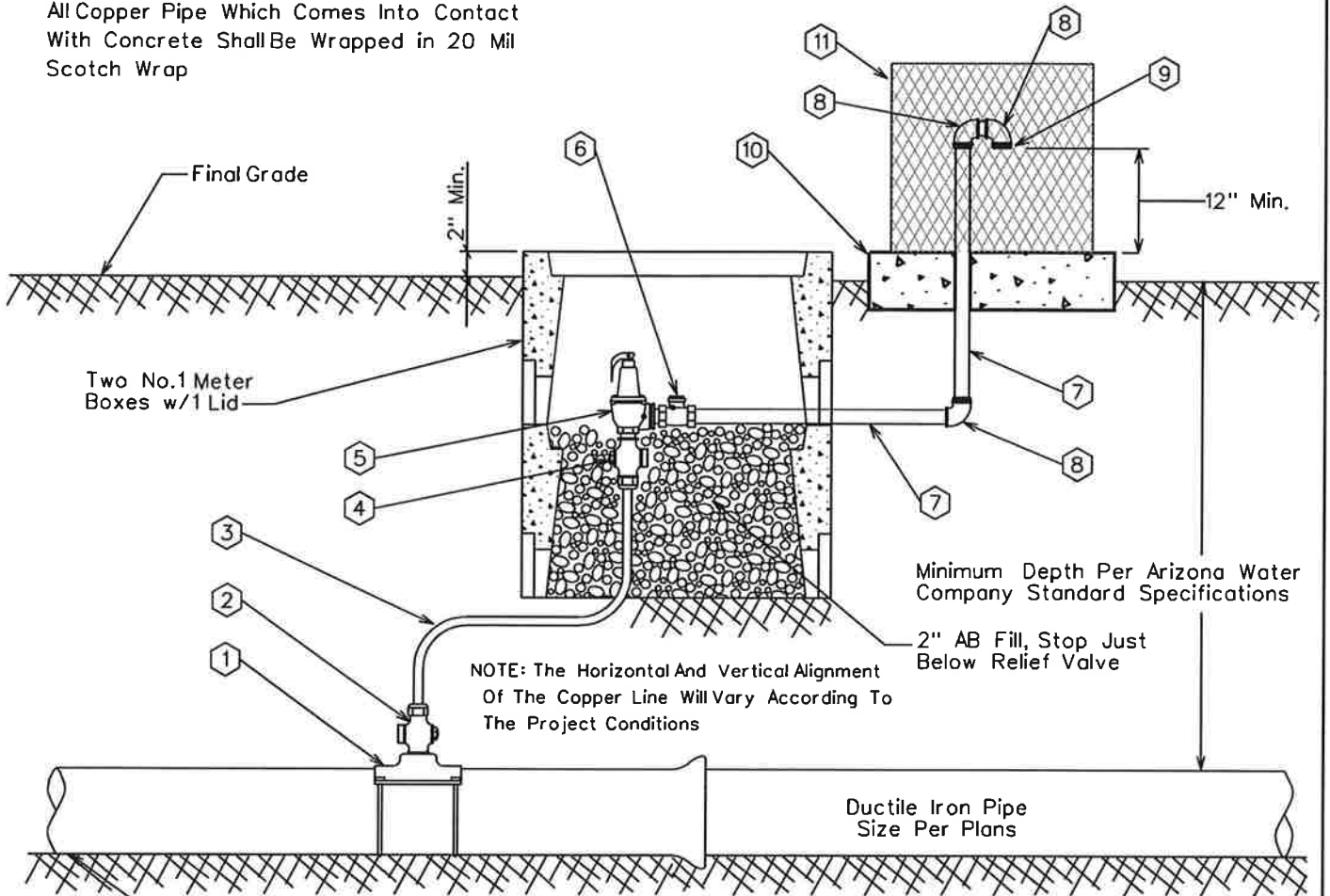

NOTE: The Horizontal And Vertical Alignment Of The Copper Line Will Vary According To The Project Conditions

Minimum Depth Per Arizona Water Company Standard Specifications

2" AB Fill, Stop Just Below Relief Valve

Ductile Iron Pipe Size Per Plans

NOTE:

- 1. Pressure relief valves are typically located just down stream of a pressure reducing station or where system conditions might be subject to greater than allowable pressures.
- 2. The relief valve assembly and vandal enclosure shall be located out of the roadway, but within the right-of-way or easement.

FITTINGS SCHEDULE	
1.	Mueller BR2B Bronze Service Saddle - Double Strap
2.	2" Mueller B-25008 Taper x Comp. Ball Corp Stop
3.	2" Type 'M' Rigid Copper w/NO Splices - Field Fit
4.	2" Mueller B-25028 IP x Comp. Ball Corp Stop
5.	2" Pressure Relief Valve Watts 174A With A 2" Inlet / 2" Outlet 30-150 psi W/ Bronze Body
6.	2" Bronze Check Valve Watts Series CV
7.	2" Schedule 40 Cut Pipe - Field Fit
8.	2" Brass Street Elbow
9.	No.16 Wire Mesh Screen (Non-Corrodible)
10.	4" Thick Concrete Pad - Class 'C' Concrete
11.	Guardshack, Model GS-1, Available From BPD, Inc. Available In Leaf Green Or Desert Tan

ARIZONA WATER COMPANY

STANDARD SPECIFICATION FOR THE INSTALLATION OF			
PRESSURE RELIEF VALVE - NORTHERN REGION			
DRAWN BY: CCO	APPROVED BY: MW	DATE: 3/20/1986	△08.29.2006 E-9-14-2

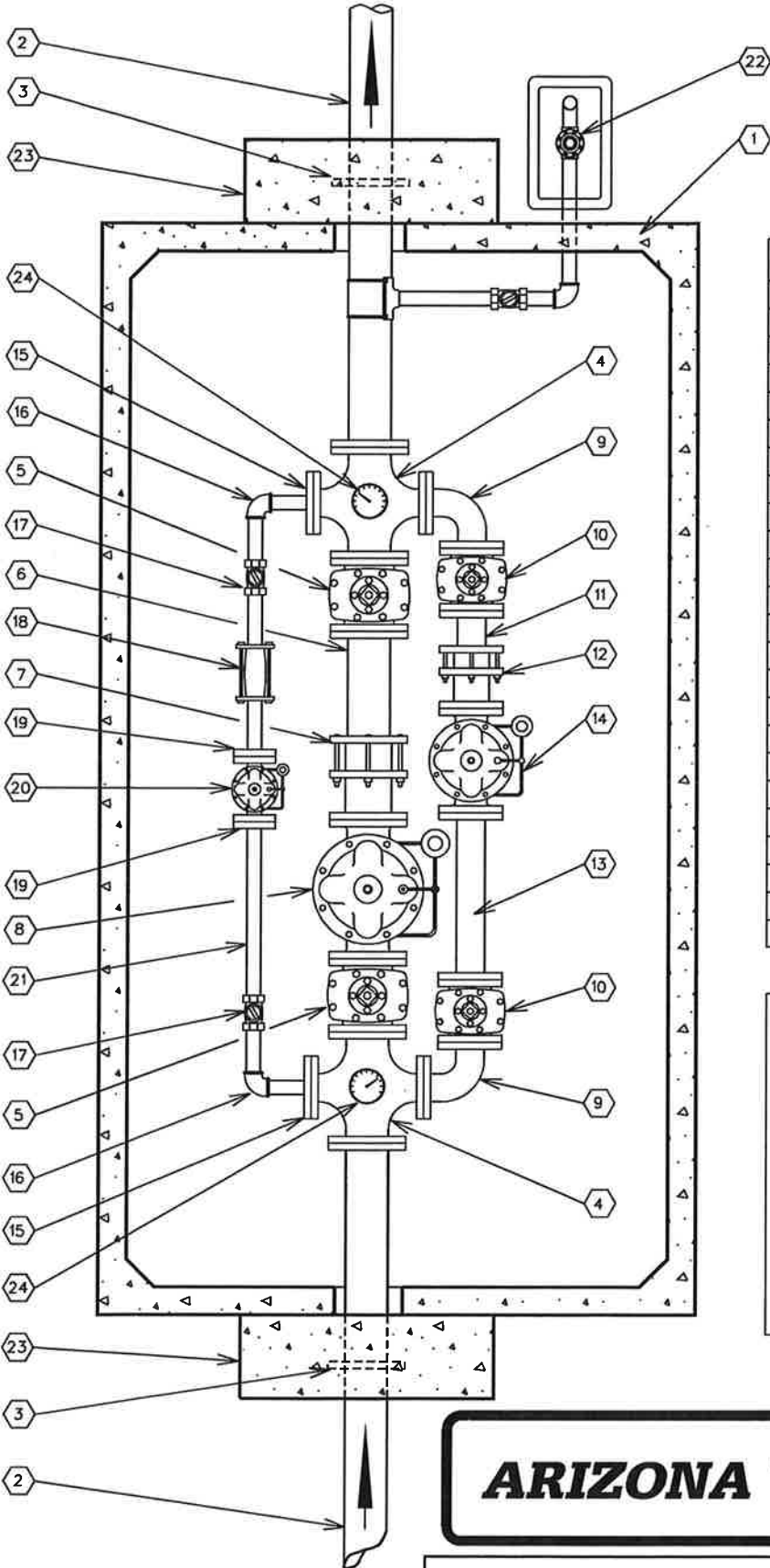

No.	FITTINGS SCHEDULE
1.	612 LA Conc. Vault (See Note 3)
2.	6"x6'-0" D.I.P. Spool Flg.xP.E.
3.	6" Megalug (Thrust Anchor)
4.	6"x4" Cross Flg.
5.	6" Gate Valve Flg.
6.	6"x2'-0" D.I.P. Spool Flg.xP.E.
7.	6" Flg. Coup. Adapt. (Rockwell 913)
8.	6" High Flow Pressure Reducing Valve Flg.
9.	4" 90° Ell. Flg.
10.	4" Gate Valve Flg.
11.	4"x1'-0" D.I.P. Spool Flg.xP.E.
12.	4" Flg. Coup. Adapt. (Rockwell 913)
13.	4"x2'-0" D.I.P. Spool Flg.
14.	4" Medium Flow Pressure Reducing Valve Flg.
15.	2"x9" O.D. Reducing Flg. (I.P.T.)
16.	2" 90° Ell. F.I.P.
17.	2" Ball Valve F.I.P.
18.	2" Comp. Coup. (Rockwell 411)
19.	2" Companion Flg. (I.P.T.)
20.	2" Low Flow Pressure Reducing Valve Flg.
21.	2" Sched. 40 Stl. Pipe
22.	2" Pressure Relief Valve (See E-9-14-1)
23.	12"x36"x36" Conc. Thrust Block P.I.P.
24.	Pressure Gauge w/shut off valve

NOTE:

1. Use Rowley pipe supports or equivalent as needed. (See E-9-12-4)
2. Pipe support locations to be determined by field personnel.
3. Vault-612 LA top section w/12" Dia. sump hole. Cover-concrete slab top w/(4) 4'-0" x2'-6" aluminum spring loaded hinged style covers for non-traffic loading areas. For areas w/low density traffic, cover is to be designed for H-20 traffic loading.
4. All Sched. 40 Stl. pipe outside of vault to be wrapped w/10-20 Mil. Scotchwrap corrosion protection tape.
5. Use deflection fittings (45° Ells.) to achieve necessary depths & cover as shown on the standard specification for the installation of a concrete vault (E-9-12-5).

ARIZONA WATER COMPANY

**STANDARD SPECIFICATION
FOR THE INSTALLATION OF
PRESSURE REDUCING STATION**

DRAWN BY: JPK	APPROVED BY: MW	DATE: 11-16-88	△ 9-27-95
------------------	--------------------	-------------------	-----------

E-9-15-1

1. Specific Items To Be Painted Deer-O Pure White Enamel:

- A. All Booster Pumps.
- B. All Electrical Motors And Gas Engines.
- C. Well Pump Discharge Heads.
- D. Electrical Panel.

2. Specific Items To Be Painted Frost Cap White Or Deer-O Pure White Enamel:

- A. Well Shelter.

3. Specific Items To Be Painted OSHA Orange:

- A. Electrical Conduit.

4. All Other Items To Be Painted With Either:

(At Manager's Discretion)

- A. Cholla Green
- B. Forest Green
- C. Sonora Beige
- D. Red Rock
- E. Rock Brown
- F. Deer-O Pure White
- G. Elkhorn Cactus

ARIZONA WATER COMPANY

STANDARD SPECIFICATION
FOR THE INSTALLATION OF

PAINT COLOR SELECTION

DRAWN BY:

CCO

APPROVED BY:

DATE:

3/20/1986

△ 2/13/2001

E-9-16-1

1. Tank shall conform to AWWA Specification D100-84 with exceptions noted below.
- 2. $\frac{1}{4}$ " minimum shell plate.
3. Minimum of 12" diameter roof vent, screened with No. 16 non-corrodible wire mesh, to be located on a 24" diameter round hinged manhole opening at the center of the tank to provide access to the dollar plate.
4. Overflow pipe shall be the same diameter as the inlet pipe and shall terminate 12 to 24 inches above splash pad or a minimum of 2 overflow pipe diameters above weir box high water level.
5. Storage tank shall be placed upon adequately compacted base material.
6. 6" minimum floor mounted tank drain outlet to be located close to the outer shell.
7. Tank and related fittings shall be enclosed with a 6 foot chain link fence with lockable gates and anti-personnel wire on top of fence.
8. Liquid level shall be indicated by a target and target board on the outside surface of the tank.
9. 24 inch diameter manholes shall be provided on the roof and on the shell near the bottom of the tank. The roof manhole cover shall overlap the manhole by at least 2 inches to provide a rain tight closure. Roof manhole shall be hinged and equipped with a lock. Shell manhole cover to be hinged and bolted in place. *Tanks larger than a 60 foot diameter require 2 shell manholes.
10. Inside and outside ladders shall be located at the roof manhole. Outside ladder shall be caged with locking trap door. Bottom 8 feet of cage shall be enclosed to within $\frac{1}{2}$ " of shell with 10 gauge sheet steel.
11. Finished tank shall be disinfected in accordance with Arizona Department of Health Services Engineering Bulletin No. 8 before being placed into service.
12. The following information will be included with application for approval to construct:
 1. Tank location _____
 2. Tank height _____
 3. Tank diameter _____
 4. Tank capacity _____
 5. Method of water level control _____
13. The storage tank will not be constructed within the 100 year flood plain and the tank site will be graded to slope away from the tank.
14. The welded steel storage tank will be coated as per AWWA Specification D102, and N.S.F. Standard 61.

*Exceptions to AWWA Specification D100-84

FOUNDATION NOTES

1. FINISH CONCRETE SURFACE MUST SLOPE UPWARDS FROM THE STEEL BAND APPROX. 1" IN 10'-0".
2. TOP OF STEEL BAND MUST BE MAINTAINED LEVEL TO WITHIN $\frac{1}{8}$ ".
3. INSTALL 8-2" DIA. x 10'-0" P.V.C. WEEP LINES, EQUALLY SPACED (EVERY 45°). PERFORATE 8'-0" OF LINE WITH $\frac{1}{2}$ " DIA. HOLES @ 6" O.C. PLUG INTERIOR END OF LINE w/ 2" CAP.

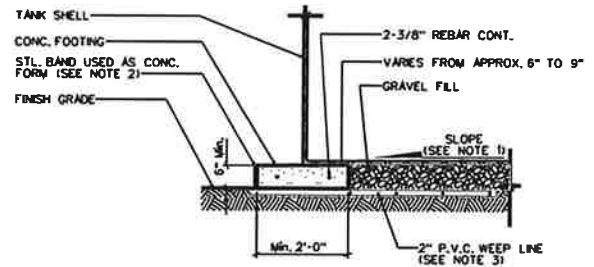

FOUNDATION DETAIL

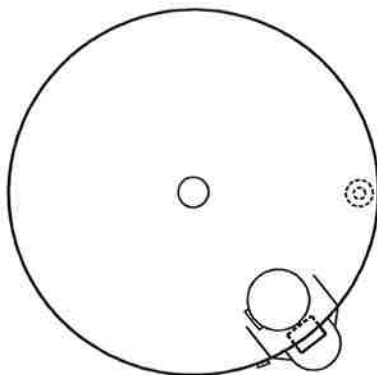

PLAN VIEW

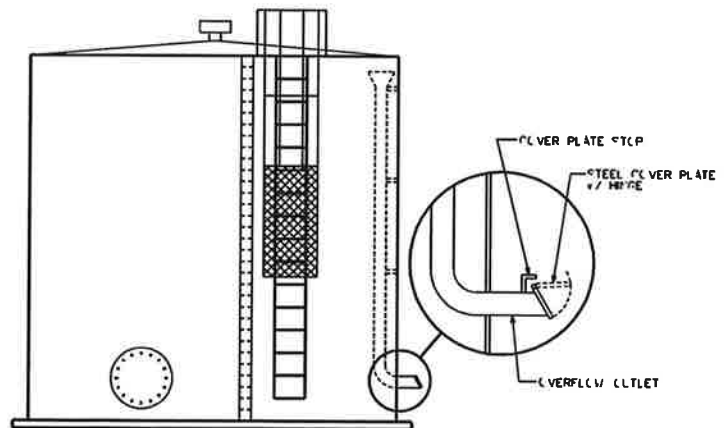

PROFILE VIEW

ARIZONA WATER COMPANY

STANDARD SPECIFICATION
FOR THE INSTALLATION OF

STEEL WATER STORAGE TANK

DRAWN BY: JPK	APPROVED BY: MJW	DATE: 10-17-88	△ 2-12-96	E-9-17-1
------------------	---------------------	-------------------	-----------	----------

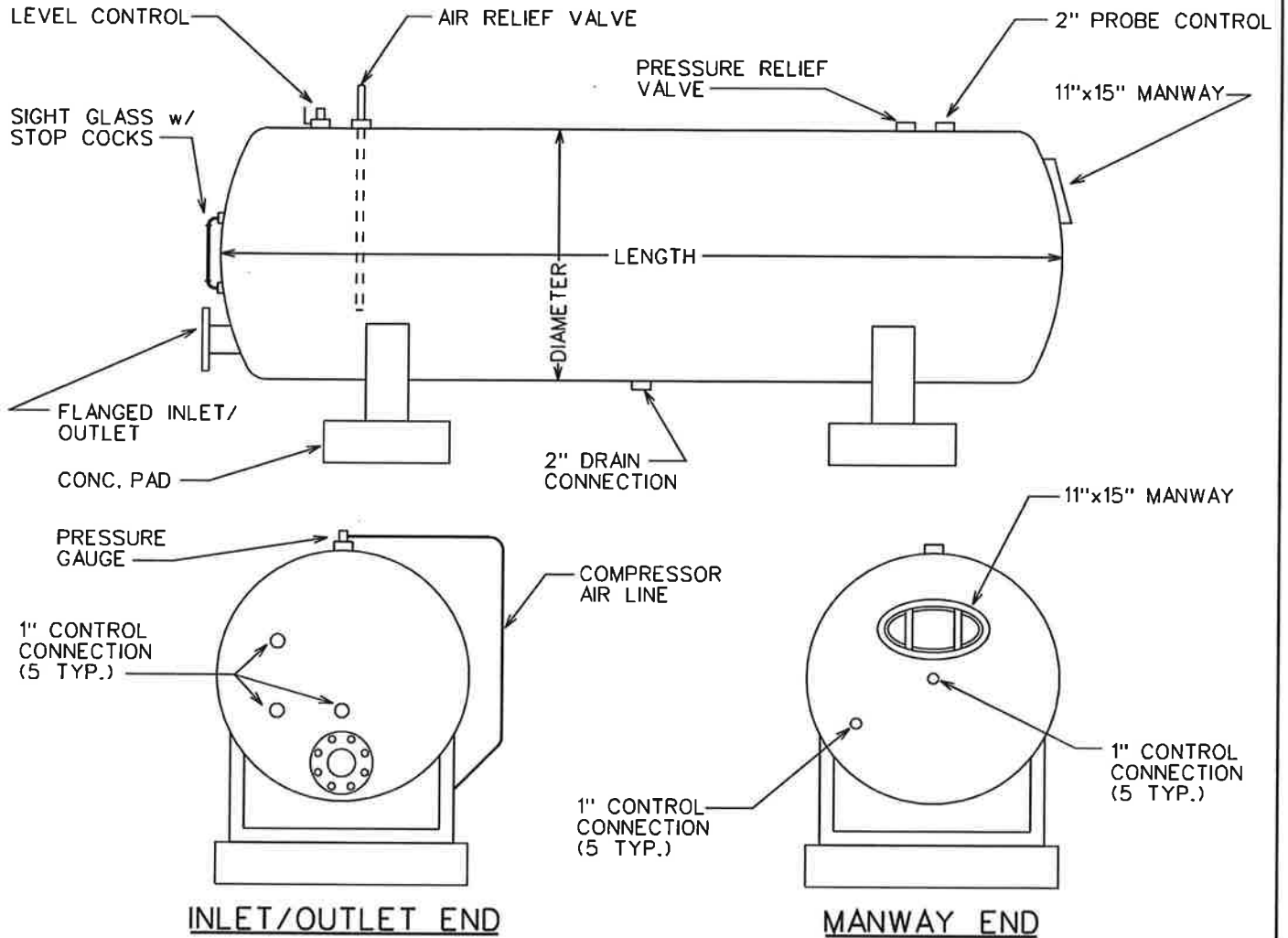

1. ALL HYDROPNEUMATIC TANKS SHALL BE DESIGNED & CONSTRUCTED IN ACCORDANCE WITH THE CURRENT REQUIREMENTS OF THE ASME CODE FOR UNFIRED PRESSURE VESSELS, SECTION VIII, DIVISION 1.
2. FINISHED TANK SHALL BE DISINFECTED IN ACCORDANCE WITH ADEQ BULLETIN No. 8 BEFORE BEING PLACED INTO SERVICE.
3. THE WELDED STEEL HYDROPNEUMATIC TANK WILL BE COATED AS PER AWWA SPECIFICATION D102 & NSF STANDARD 61.
4. THE FOLLOWING INFORMATION WILL BE INCLUDED WITH THE APPLICATION FOR APPROVAL TO CONSTRUCT.
 1. Tank Location _____
 2. Tank Length _____
 3. Tank Diameter _____
 4. Tank Capacity _____
 5. Maximum Working Pressure _____

ARIZONA WATER COMPANY

STANDARD SPECIFICATION FOR THE INSTALLATION OF

HYDROPNEUMATIC TANK

DRAWN BY: JPK	APPROVED BY: MW	DATE: 3-20-1986	△ 01.16.2007
			E-9-18-1

NOT
CONVERTED
TO
CAD

ARIZONA WATER COMPANY

STANDARD SPECIFICATION
FOR THE INSTALLATION OF

WELL SHELTER

DRAWN BY:

CB

APPROVED BY:

DATE:

03.20.1986

△ 04.03.2001

E-9-19-1

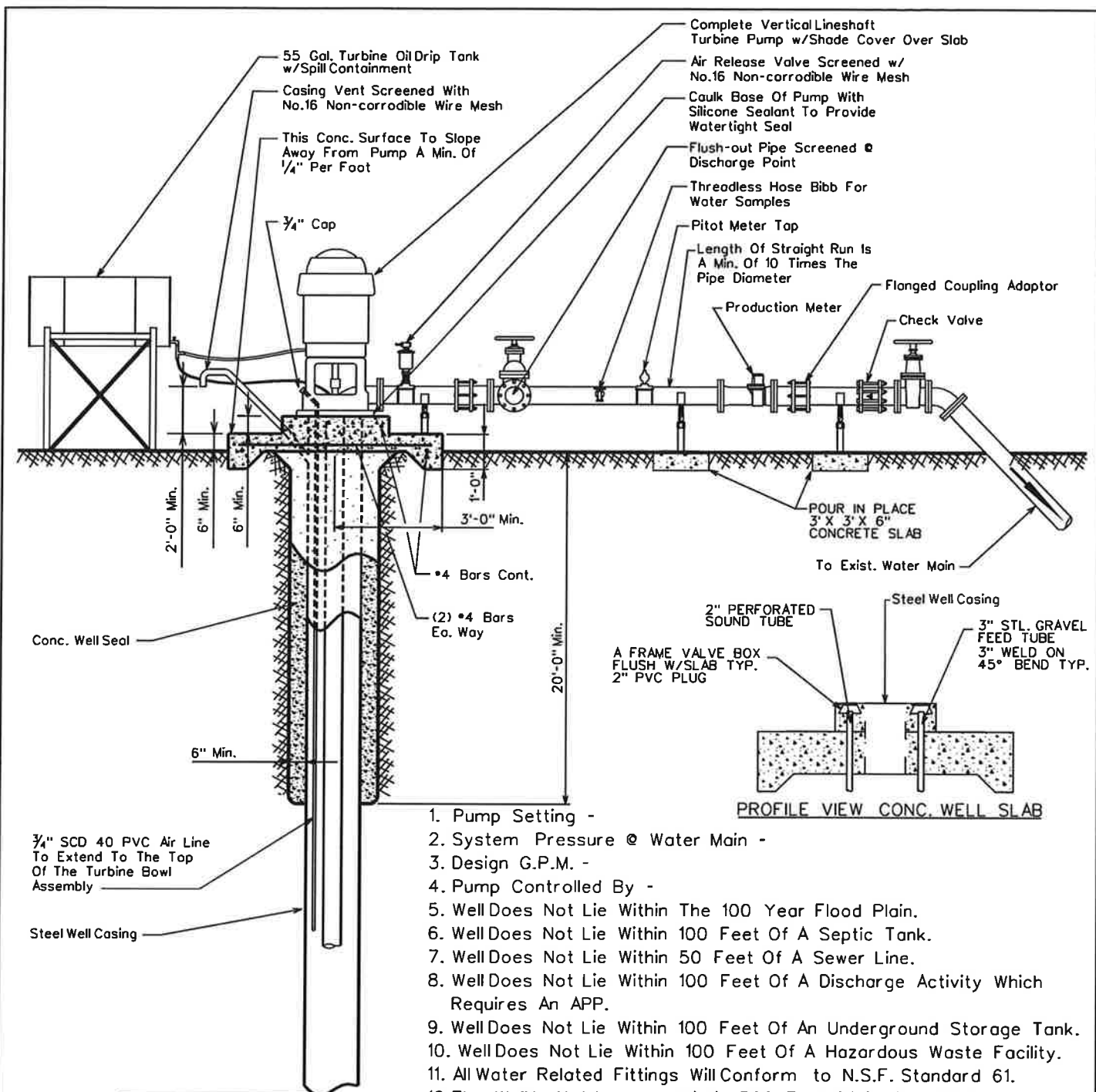

PROFILE VIEW CONC. WELL SLAB

1. Pump Setting -
2. System Pressure @ Water Main -
3. Design G.P.M. -
4. Pump Controlled By -
5. Well Does Not Lie Within The 100 Year Flood Plain.
6. Well Does Not Lie Within 100 Feet Of A Septic Tank.
7. Well Does Not Lie Within 50 Feet Of A Sewer Line.
8. Well Does Not Lie Within 100 Feet Of A Discharge Activity Which Requires An APP.
9. Well Does Not Lie Within 100 Feet Of An Underground Storage Tank.
10. Well Does Not Lie Within 100 Feet Of A Hazardous Waste Facility.
11. All Water Related Fittings Will Conform to N.S.F. Standard 61.
12. The Well Is Not Located Within 500 Feet Of Surface Water.
13. The Site Will Be Graded To Provide Adequate Drainage Away From The Well.
14. 6.88 lbs. of Davis #8084 Grey Dye, Per Yard, For 2500 PSI Concrete

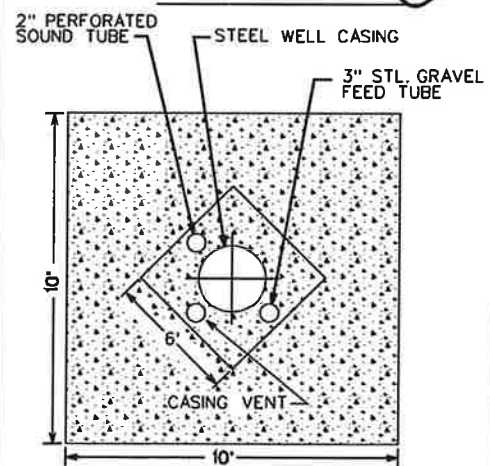

PLAN VIEW CONC. WELL SLAB

ARIZONA WATER COMPANY

STANDARD SPECIFICATION
FOR THE INSTALLATION OF

TYPICAL WELL W/ LINESHAFT TURBINE PUMP

DRAWN BY: JW	APPROVED BY: M.W.	DATE: 3-20-86	△ 9/15/04
			E-9-20-1

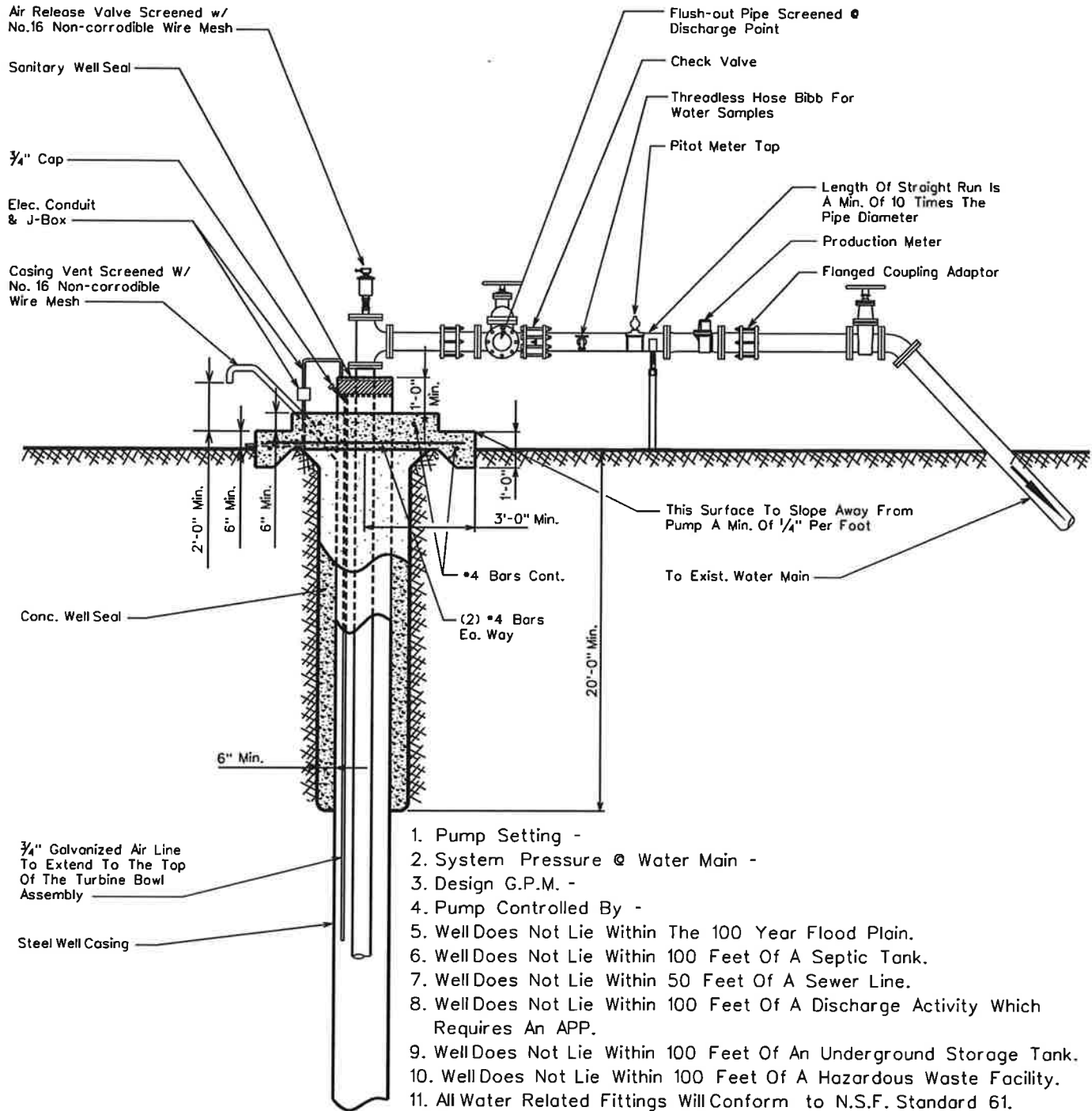

1. Pump Setting -
2. System Pressure @ Water Main -
3. Design G.P.M. -
4. Pump Controlled By -
5. Well Does Not Lie Within The 100 Year Flood Plain.
6. Well Does Not Lie Within 100 Feet Of A Septic Tank.
7. Well Does Not Lie Within 50 Feet Of A Sewer Line.
8. Well Does Not Lie Within 100 Feet Of A Discharge Activity Which Requires An APP.
9. Well Does Not Lie Within 100 Feet Of An Underground Storage Tank.
10. Well Does Not Lie Within 100 Feet Of A Hazardous Waste Facility.
11. All Water Related Fittings Will Conform to N.S.F. Standard 61.
12. The Wells Not Located Within 500 Feet Of Surface Water.
13. The Site Will Be Graded To Provide Adequate Drainage Away From The Well.

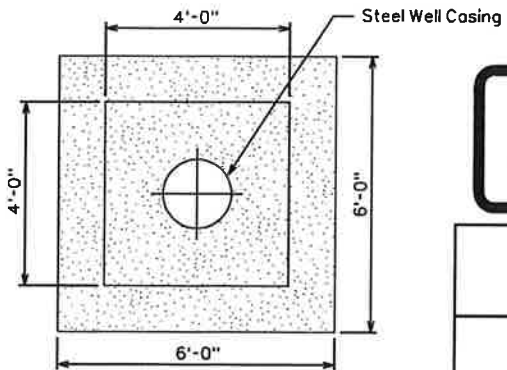

PLAN VIEW CONC. WELL SLAB

ARIZONA WATER COMPANY

**STANDARD SPECIFICATION
FOR THE INSTALLATION OF**

TYPICAL WELL W/ SUBMERSIBLE TURBINE PUMP

DRAWN BY: jpk	APPROVED BY: M.W.	DATE: 3-20-86	△ 2-16-01
---------------	-------------------	---------------	-----------

E-9-21-1

All New Purchases To Conform To The Following:

Column Pipe

4" I.D. - 8	Threads	Per Inch	Tapered	$\frac{3}{4}$ "	Per Foot	Right Hand		
6" I.D. - 8	"	"	"	"	"	"	"	"
8" I.D. - 8	"	"	"	"	"	"	"	"
10" I.D. - 8	"	"	"	"	"	"	"	"
12" I.D. - 8	"	"	"	"	"	"	"	"
14" I.D. - 8	"	"	"	"	"	"	"	"

Oil Tube - Peerless Type

1 $\frac{1}{2}$ " O.D. - 14	Threads	Per Inch	Right Hand	
2" O.D. - 12	"	"	"	"
2 $\frac{1}{2}$ " O.D. - 10	"	"	"	"
3" O.D. - 10	"	"	"	"
3 $\frac{1}{2}$ " O.D. - 10	"	"	"	"
4" O.D. - 10	"	"	"	"

Line Shaft

$\frac{3}{4}$ " O.D. - 10	Threads	Per Inch	Left Hand	
1" O.D. - 14	"	"	"	"
1- $\frac{3}{16}$ " O.D. - 10	"	"	"	"
1- $\frac{1}{2}$ " O.D. - 10	"	"	"	"
1- $\frac{11}{16}$ " O.D. - 10	"	"	"	"
1- $\frac{15}{16}$ " O.D. - 10	"	"	"	"
2- $\frac{3}{16}$ " O.D. - 10	"	"	"	"
2- $\frac{7}{16}$ " O.D. - 8	"	"	"	"

ARIZONA WATER COMPANY

STANDARD SPECIFICATION
FOR THE INSTALLATION OF

COLUMN PIPE, OIL TUBE AND LINE SHAFT

DRAWN BY:

CCO

APPROVED BY:

DATE:

3/20/1996

△ 2/13/2001

E-9-22-1

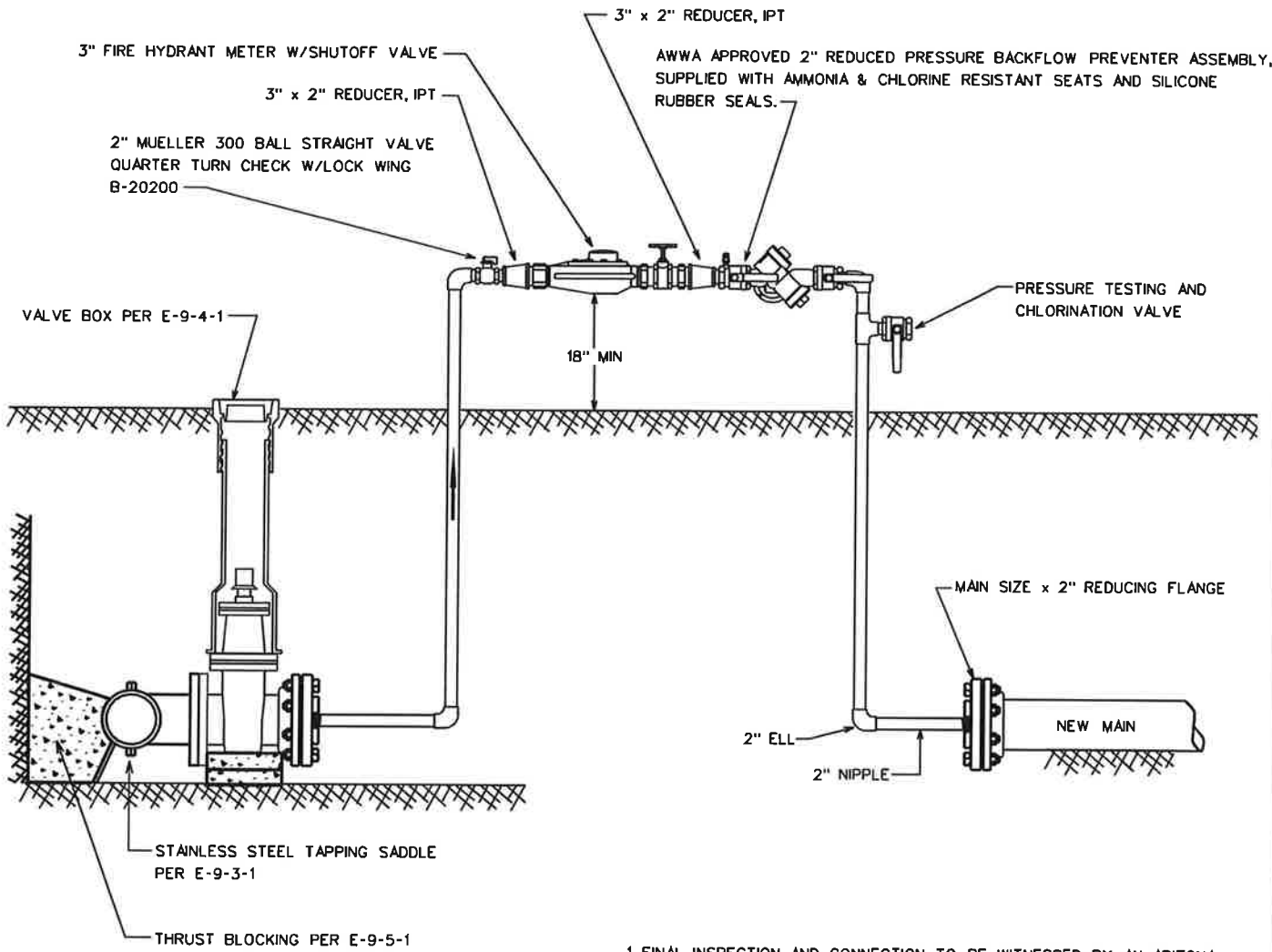

1. FINAL INSPECTION AND CONNECTION TO BE WITNESSED BY AN ARIZONA WATER COMPANY REPRESENTATIVE.
2. REDUCING FLANGES TO BE PROPERLY RESTRAINED.
3. INSTALL JUMPER TAP FOR TEMPORARY METER DOWNSTREAM OF THE REDUCING FLANGE FOR PRESSURE AND BACTEE TESTING.
4. JUMPER ASSEMBLY MUST BE A MINIMUM OF 18" ABOVE FINISHED GRADE.
5. BACKFLOW ASSEMBLY REQUIRES CERTIFICATION.
6. ASSEMBLY NOT TO BE REMOVED AND SPOOL PIECE INSTALLED FOR FINAL CONNECTION UNTIL ALL TESTING, BACTERIAL CLEARANCE AND FINAL INSPECTIONS HAVE BEEN OBTAINED.
7. ALL NEW PIPING SHALL BE PROPERLY RESTRAINED.

ARIZONA WATER COMPANY

STANDARD SPECIFICATION
FOR THE INSTALLATION OF

HOT TAP & JUMPER METER CONNECTION

DRAWN BY: CB	APPROVED BY: MJW	DATE: 05.14.2004	△
------------------------	----------------------------	----------------------------	---

E-9-23-1

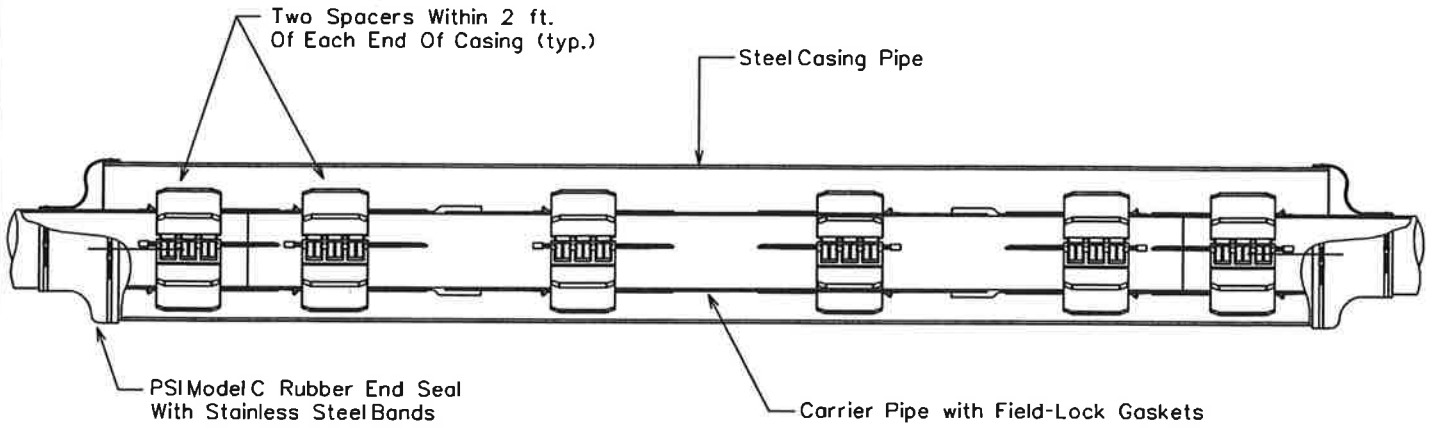

CROSS SECTION

The casing spacers shall be the PSIRanger II Casing Spacers as manufactured by Pipeline Seal and Insulator, Inc., Houston, Texas.

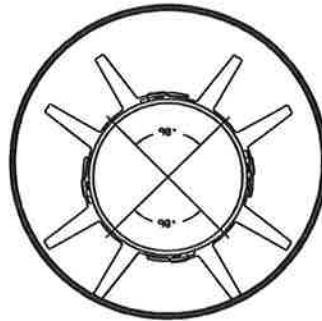

SECTION CUT

End Seals

After insertion of the carrier pipe into the casing, the ends of the casing shall be closed by installing 1/8" thick synthetic rubber end seals equal to the PSI Model "C" end seal as manufactured by Pipeline Seal and Insulator, Inc., Houston, Texas.

NOTE: The Carrier Pipe Shall Be Polywrapped Prior To The Skid Installation & Insertion Into The Carrier Casing For Divisions Requiring Polywrapped Pipe.

*Thickness Of Skid To Extend A Minimum of 1/2" Above The O.D. Of The Pipe Bell or Gland.

OD Push On Joint Bell	OD M.J. BELL
6" - 8.66"	6" - 11.12"
8" - 10.82"	8" - 13.37"
12" - 15.05"	12" - 17.94"
16" - 19.74"	16" - 22.56"
20" - 23.98"	20" - 27.08"
24" - 28.16"	24" - 31.58"
30" - 35.40"	30" - 39.12"
36" - 41.84"	36" - 46.00"
48" - 55.94"	48" - 60.00"

PIPE SIZE	CASING SIZE	CASING SIZE ID	CASING SCHEDULE	WALL THICKNESS	SKID SIZE
6"	16"	15.25"	STD.	.375	*x4x12
8"	18"	18.25"	STD.	.375	*x4x12
12"	22"	21.25"	STD.	.375	*x4x12
16"	28"	27.25"	STD.	.375	*x4x12
20"	32"	31.25"	STD.	.375	*x4x12
24"	36"	35.25"	STD.	.375	*x4x12
30"	48"	47.25"	STD.	.375	*x4x12
36"	54"	53.25"	STD.	.375	*x4x12
48"	66"	65.25"	STD.	.375	*x4x12

ARIZONA WATER COMPANY

STANDARD SPECIFICATION

FOR THE INSTALLATION OF

TYPICAL WATER LINE ENCASEMENT

DRAWN BY: CB	APPROVED BY:	DATE: 3/20/1996	△ 09.27.2006	E-9-24-1
--------------	--------------	-----------------	--------------	----------

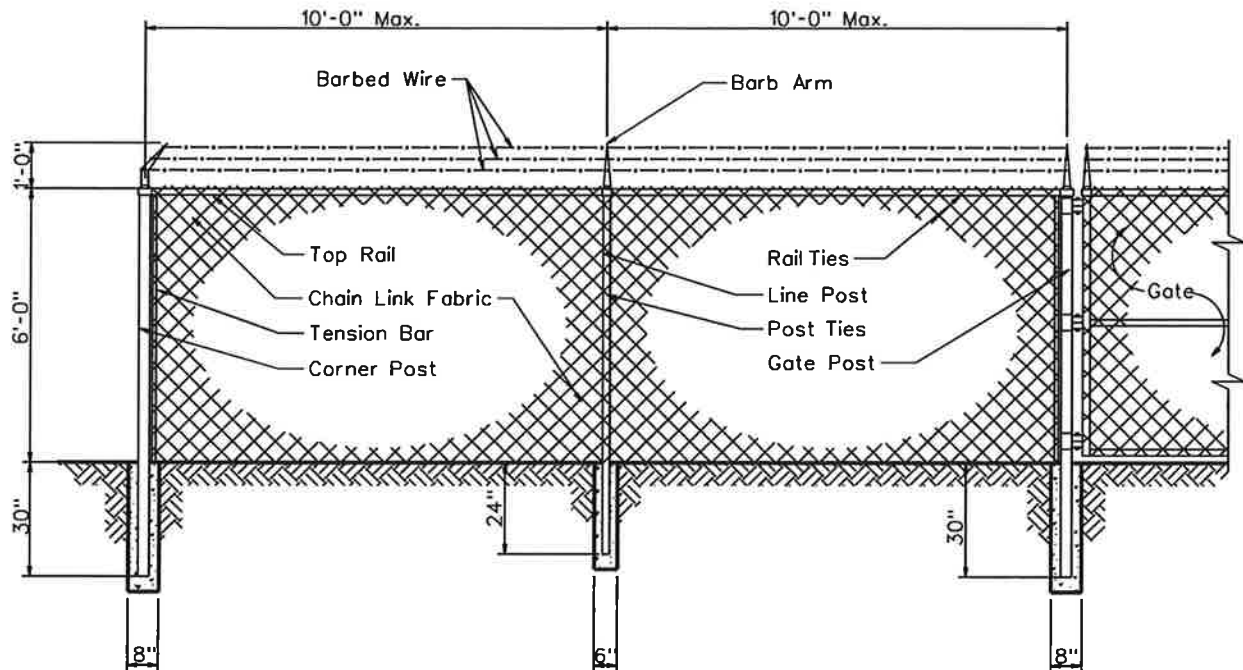

Line Post:	1-7/8" O.D.	1.74 lbs. P/L.F.	ASTM A-256
End Post:	2-7/8" O.D.	4.64 lbs. P/L.F.	ASTM A-256
Corner Post:	2-7/8" O.D.	4.64 lbs. P/L.F.	ASTM A-256
Gate Post:	2-7/8" O.D.	4.64 lbs. P/L.F.	ASTM A-256
Top Rail:	1-5/8" O.D.	4.64 lbs. P/L.F.	ASTM A-256
Chain Link Fabric:	9 Ga. 2" Mesh Galv. Before Weave		
Selvage:	Barb/Knuckle		
Fittings:	Pressed Steel		
Barb Wire:	2-1/2 Ga./2 Point		
Barb Arm:	1 Piece/45° Arm		
Tension Wire:	9 Ga./Galv.		
Line Post Set:	6"x24" In Concrete		
Terminal Post Set:	8"x30" In Concrete		

ARIZONA WATER COMPANY

STANDARD SPECIFICATION
FOR THE INSTALLATION OF

CHAIN LINK FENCE

DRAWN BY: CCO	APPROVED BY: MW	DATE: 7/7/1992	DATE: 2/9/2001
------------------	--------------------	-------------------	-------------------

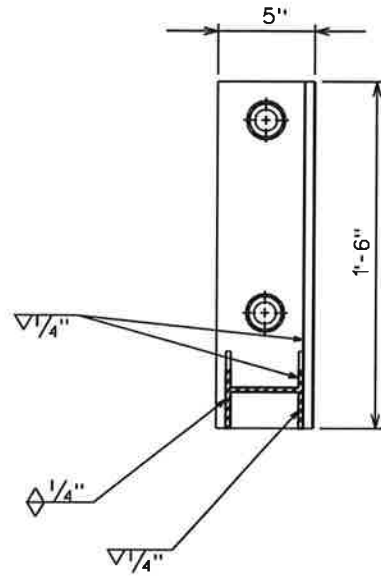

SECTION X-X

NOTES

1. Minimum 2 Supports Per Joint Of Pipe.
2. All Bolts Shall Have A Lock Washer Under The Nut.
3. All Nuts Shall Be Stainless Steel Series 304.

PIPE SIZE	A	B
8"	8"	15"
10"	9"	17"
12"	10"	19"

1/8"x12" Stainless Steel Wedge Bolts, Series 304

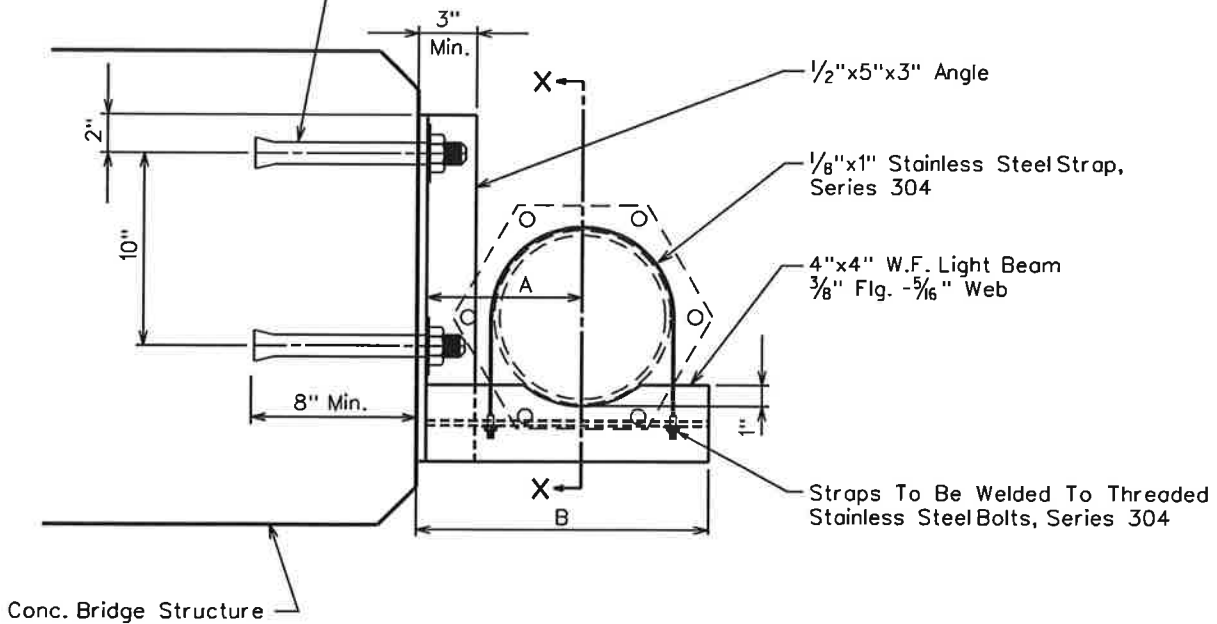

SUSPENSION DETAIL



STANDARD SPECIFICATION
FOR THE INSTALLATION OF

SIDE HUNG WATER LINE SUSPENSION

DRAWN BY: JPK	APPROVED BY: MJW	DATE: 7-12-96	△	E-9-27-1
---------------	------------------	---------------	---	----------

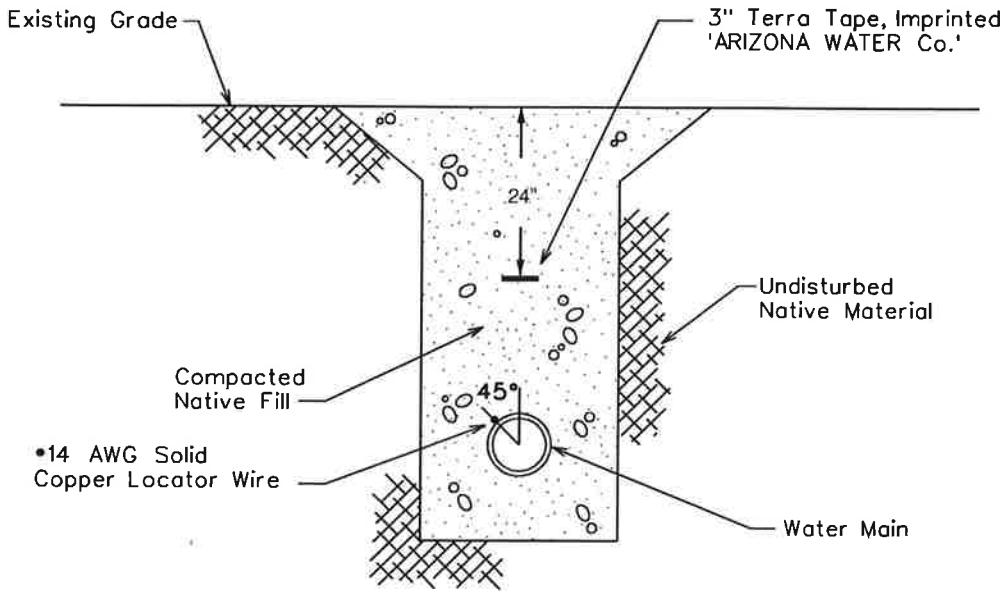

TYPICAL WATER TRENCH DETAIL

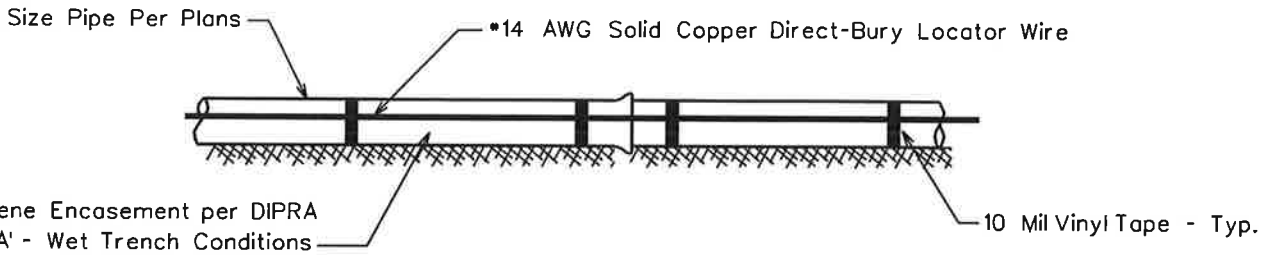

TYPICAL PROFILE VIEW

WIRE GENERAL NOTES:

1. All pipe shall have *14 AWG Solid Copper Direct-Bury Locator Wire Installed Directly To The Polywrap At 45° From The Vertical Center Of The Pipe and Shall Be Attached Using 10 Mil Vinyl Tape.
2. The Locating Wire Shall Terminate At the Top Of Each Valve Box and Be Capable of Extending 12" Above the Top Of The Box In Such A Manner So As Not To Interfere With Valve Operation.

TAPE GENERAL NOTES:

1. Use Terra Tape 3" Marking Tape As Manufactured By Reef Industries Inc. Of Houston, Texas (1-800-231-2417)
2. The Tape Is Blue & Imprinted 'ARIZONA WATER Co.'
3. INSTALLATION: The Pipe Warning Tape Shall Be Installed Over All Water Mains And Shall Be Buried 24 Inches Below The Surface Over The Center Of The Pipe.
 - A) The Backfill Shall Be Sufficiently Leveled So That The Tape Is Installed On A Flat Surface.
 - B) The Tape Shall Be Centered In The Trench With The Printed Side Up.
 - C) Care Shall Be Exercised To Avoid Movement Of The Tape While The Remaining Backfill Is Moved Into The Trench.



STANDARD SPECIFICATION
FOR THE INSTALLATION OF

PIPE WARNING TAPE AND LOCATOR WIRE

DRAWN BY: CB	APPROVED BY:	DATE: 03.24.1997	△ 09.27.2006	E-9-28-1
--------------	--------------	------------------	--------------	----------

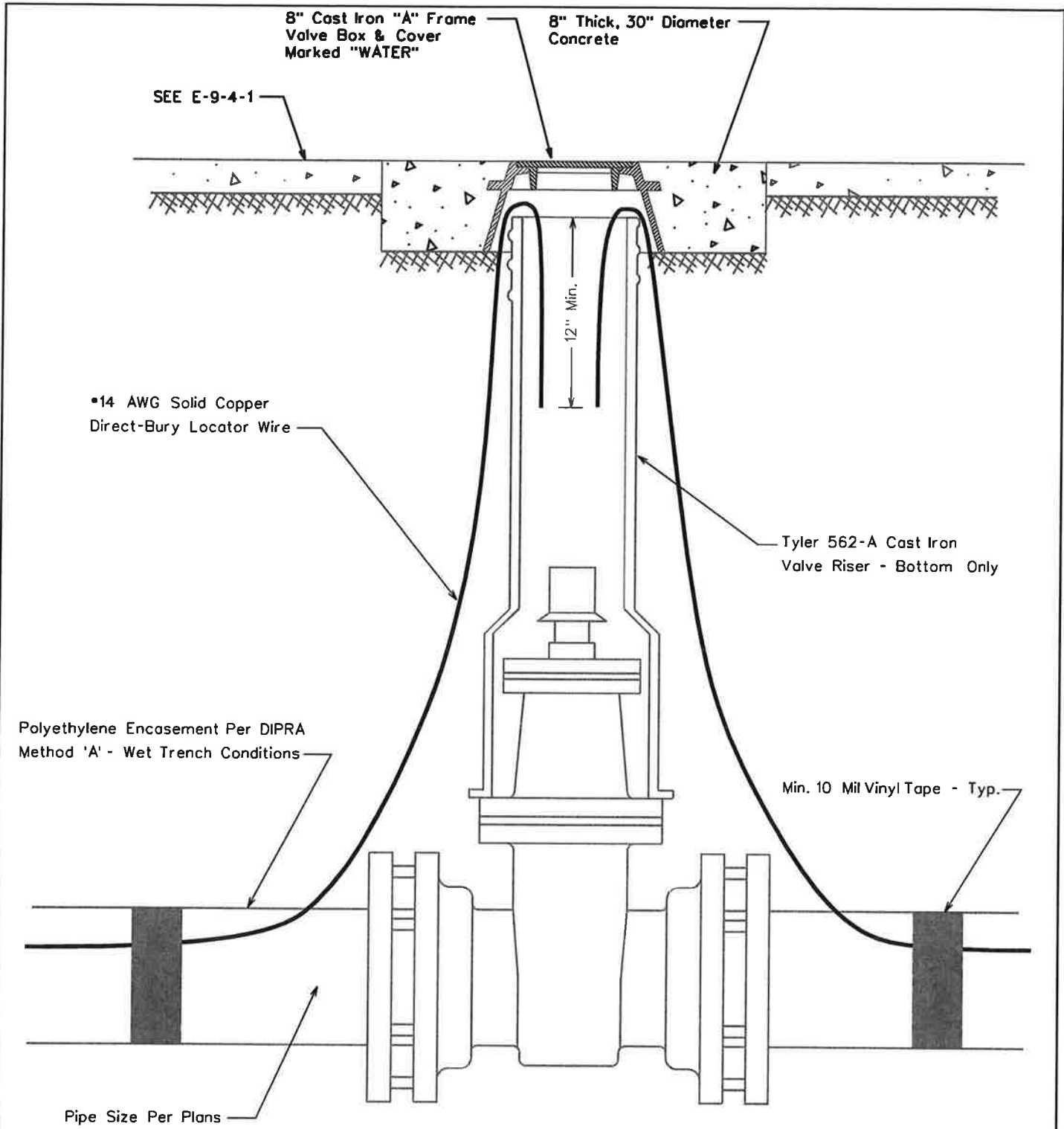

ARIZONA WATER COMPANY

STANDARD SPECIFICATION
FOR THE INSTALLATION OF

LOCATOR WIRE TERMINATION

DRAWN BY: CB	APPROVED BY:	DATE: 09.27.2006	△	E-9-28-2
--------------	--------------	------------------	---	----------

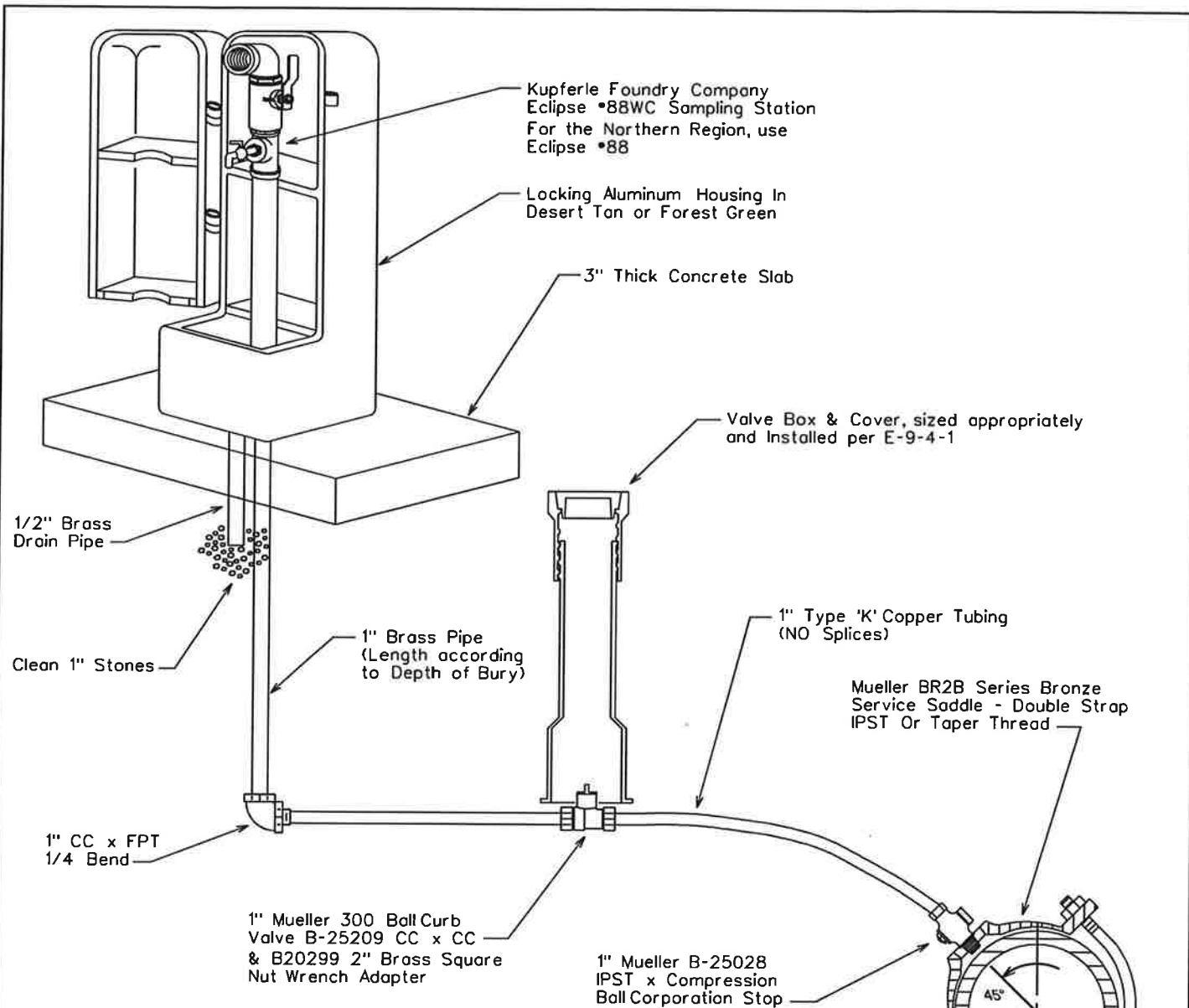

Sampling Stations shall be 1' bury, with a 1" MIP inlet, and a 1" FIP discharge. A 1/4" bent-nose sampling bibb shall be located before the discharge.

All stations shall be enclosed in a lockable, nonremovable, aluminum-cast housing.

When opened, the station shall require no key for operation, and the water will flow in an all brass waterway.

All working parts will be of brass and serviceable from above ground with no digging. (OPTIONAL: if desired, a 1/2" brass drain tube will be provided within the locking cover).

A 1" ball valve will control the water flow, and be located before (or after) the sampling bibb, as manufactured by Kupferle Foundry, St. Louis, MO 63102.

SADDLE TAP TO CA, PVC, OR DI PIPE

NOTE: The minimum distance between taps on mains other than ductile iron is 12"

Pipe Depth Per
E-8-1-2, Item 3.



STANDARD SPECIFICATION				
FOR THE INSTALLATION OF				
SAMPLING STATION				
DRAWN BY:	APPROVED BY:	DATE:		
CB	MW	01.24.2007	△	E-9-29-1

ENCASEMENT FOR PIPE CROSSING

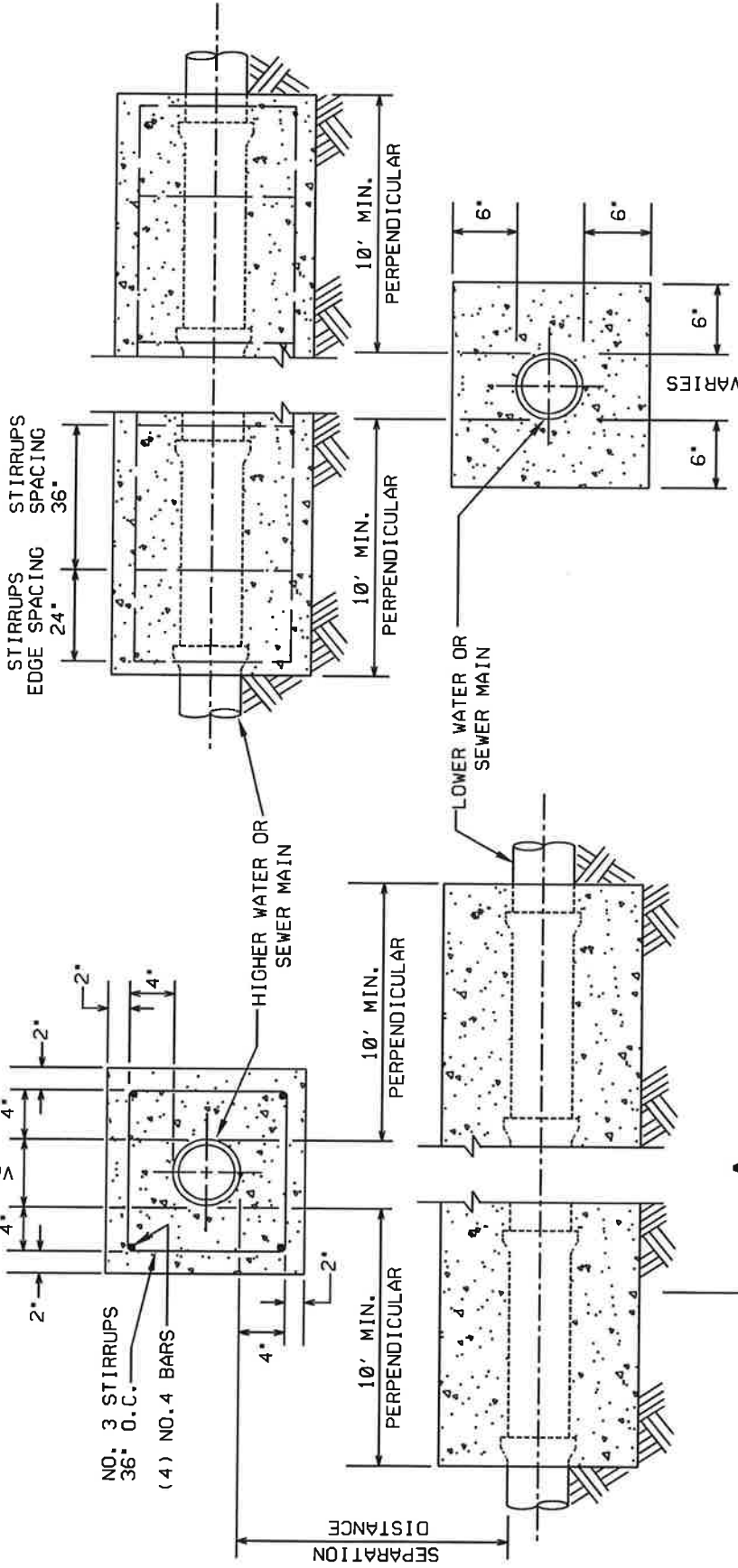

SECTION A-A



STANDARD SPECIFICATION
FOR THE INSTALLATION OF
WATER AND SANITARY SEWER
SEPARATION/PROTECTION

DRAWN BY: CB	APPROVED BY: JW	DATE: 04.07.2008	△
			E-9-30-1

NOTES:

- 2,000 PSI CONCRETE
- SEPARATION DISTANCES AND/OR OTHER EXTRA PROTECTION SHALL BE REQUIRED TO PROTECT WATER MAINS FROM CONTAMINATION BY SANITARY SEWER MAINS. SEE AWC STANDARD SPECIFICATION PAGES E-8-1-9 AND E-8-1-10.
- SEE CROSS SECTION DETAIL FOR LIMITS OF SEPARATION/EXTRA PROTECTION. ALL DISTANCES ARE MEASURED PERPENDICULARLY FROM THE OUTSIDE OF THE PIPES.
- RECLAIMED WATER SHALL BE CONSIDERED A SANITARY SEWER WHEN PLACED NEXT TO A POTABLE WATER MAIN.

NOTES:

1. 2,000 PSI CONCRETE
2. SEPARATION DISTANCES AND/OR OTHER EXTRA PROTECTION SHALL BE REQUIRED TO PROTECT WATER MAINS FROM CONTAMINATION BY SANITARY SEWER MAINS. SEE AWC STANDARD SPECIFICATION PAGES E-8-1-9 AND E-8-1-10.
3. SEE CROSS SECTION DETAIL FOR LIMITS OF SEPARATION/EXTRA PROTECTION. ALL DISTANCES ARE MEASURED PERPENDICULARLY FROM THE OUTSIDE OF THE PIPES.
4. RECLAIMED WATER SHALL BE CONSIDERED A SANITARY SEWER WHEN PLACED NEXT TO A POTABLE WATER MAIN.

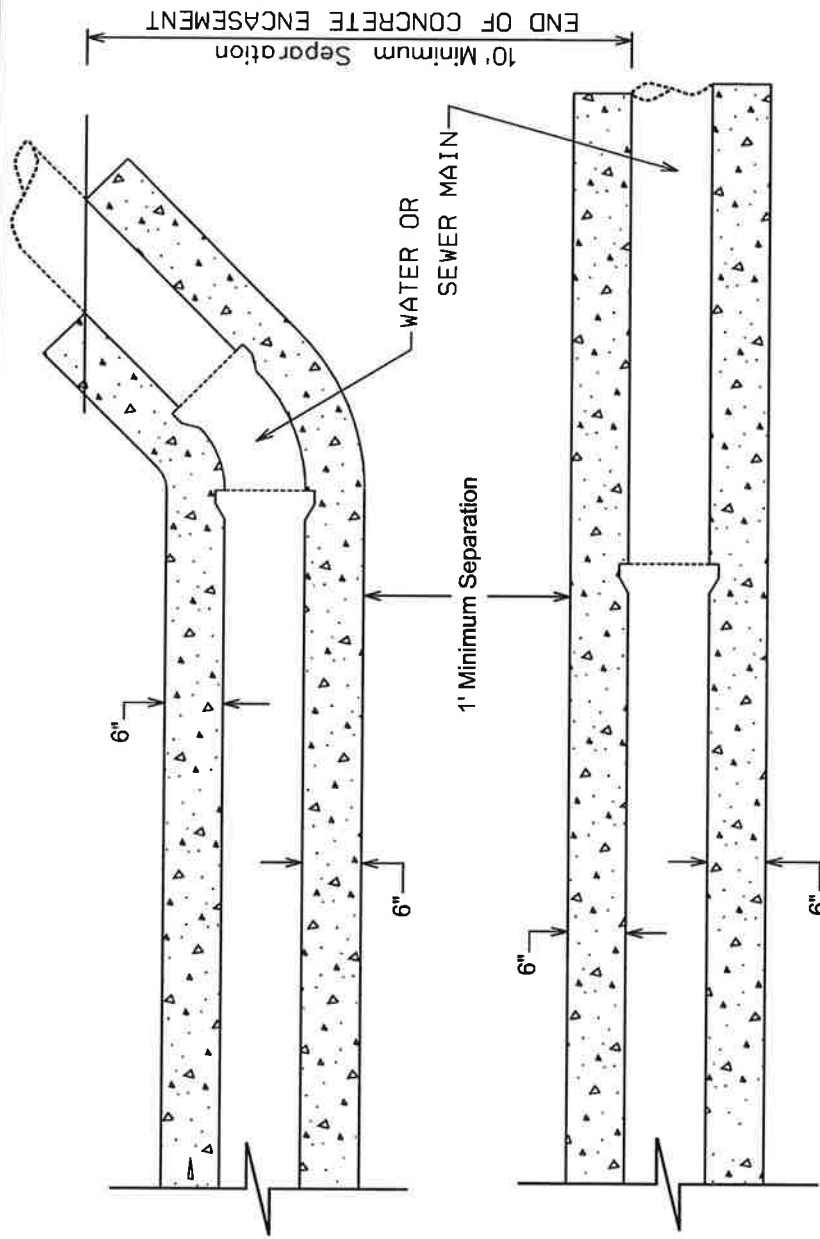

PLAN VIEW

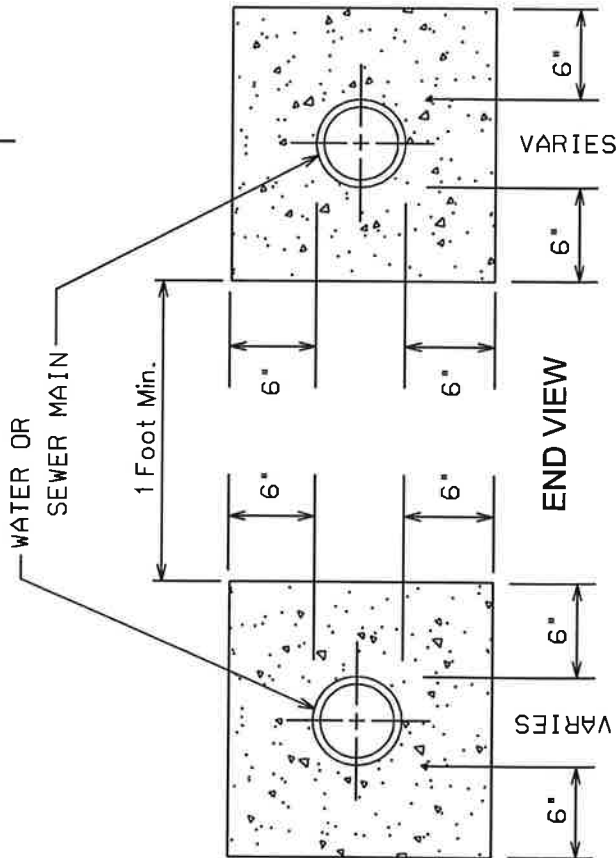

ENCASUREMENT FOR PARALLEL PIPES



STANDARD SPECIFICATION
FOR THE INSTALLATION OF

WATER AND SANITARY SEWER
SEPARATION/PROTECTION

DRAWN BY: CB

APPROVED BY: JW

DATE: 04.07.2008



E-9-30-2

This page intentionally left blank