



# THUNDER MOUNTAIN RD/SANBORN DR DRAINAGE AND SUP IMPROVEMENTS

[WWW.SEDONAAZ.GOV/SIM](http://WWW.SEDONAAZ.GOV/SIM)



# Project Improvements



- Drainage
- SUP
- Curb & Gutter
- Pavement

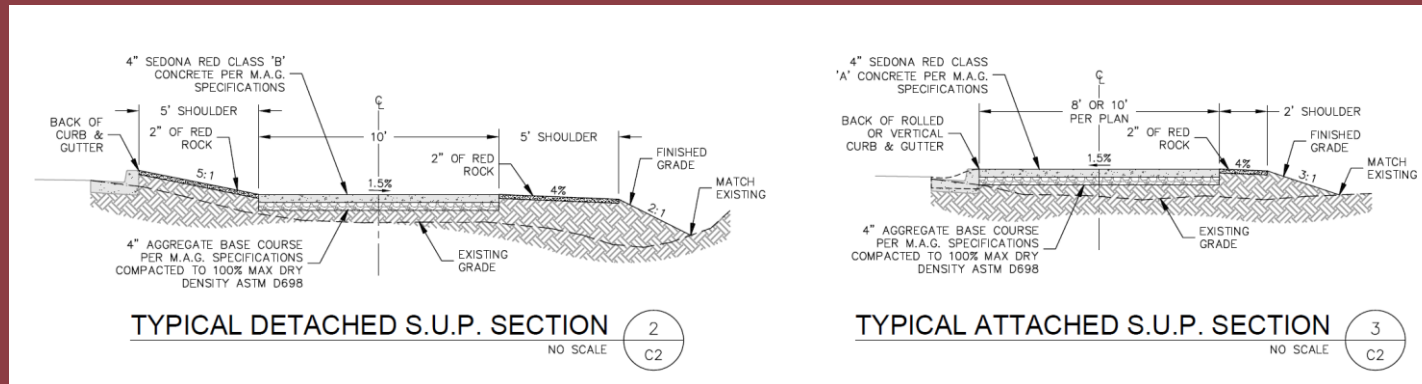

- [Video](#)

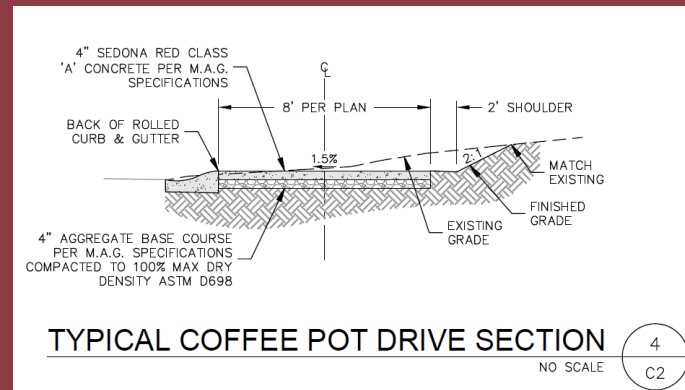

# Drainage



- 2005 Drainage Master Plan
  - Complete upper portion of Harmony – Windsong Drainage System
  - Other drainage improvements throughout the corridor

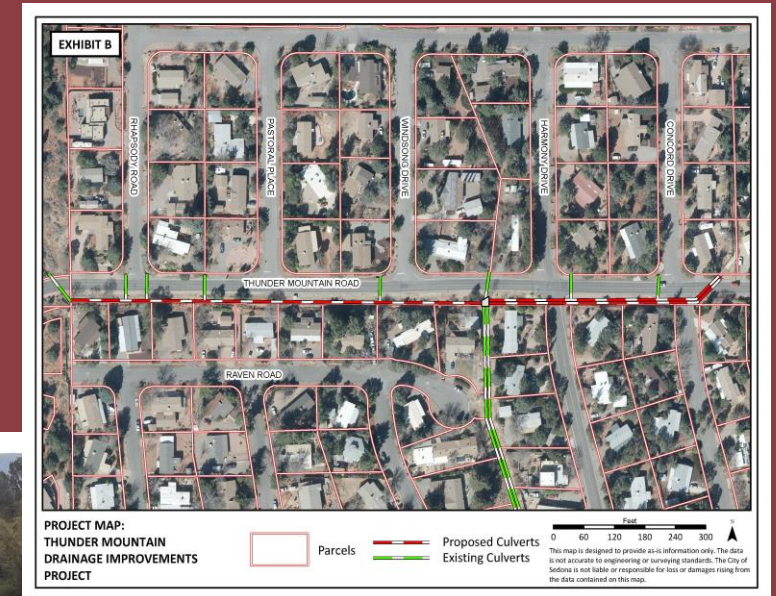



# Transportation – Walk / Bike

- 2018 Transportation Master Plan Update
  - Bicycling can help relieve congestion in Sedona.
  - Bicycle and pedestrian facilities are generally inexpensive.
  - More people walking and bicycling reduces the need for roads and parking.
  - Walking and bicycling helps the environment and improves air quality.
  - Bicycling and walking can help residents stay healthy.
- Go Sedona
- Some locals have expressed support for this project due to improved safety.

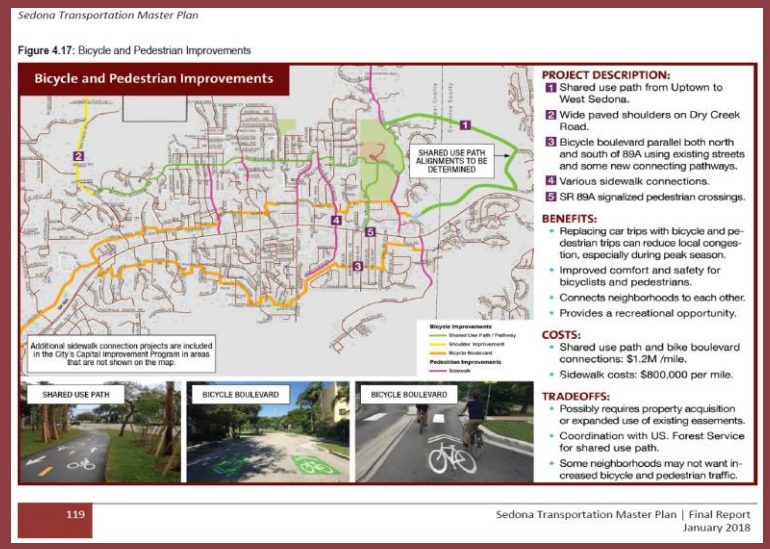

# Transportation – Walk / Bike



# Outreach/Surveys/Plans

- 1994 Red Rock Pathways Plan
- 1996 Trails and Urban Pathways Plan
- 2007 Sedona Bicycle Plan
- 2017 Community Survey
- 2018 Transportation Master Plan (Strategy 11)
- FY2020/2021 Budget Survey
- 2020 GO Sedona, Trails & Pathways Master Plan Update



# Project Specific Outreach Efforts



- July 9, 2019: Letters sent to owners north of SR 89A in central W. Sedona inviting the public to share their ideas during the design process. This letter included a proposed SUP rendition.
- Packets containing letters, project information and plans were left with 90 residents throughout the project corridor in early 2020
- Letters and exhibits requesting temporary construction easements were sent to 21 property owners between June and July 2020
- A FAQ sheet was posted on Nextdoor
- Support vs. Opposition





# Schedule

- FY20 – SUP & Drainage design was completed, and the Thunder Mountain Drainage Project was completed
- FY21 - Complete drainage construction, construct SUP, curb & gutter, and paving





# Contract

- Local – Tiffany Construction Company (low bidder out of six contractors)
- Tiffany has done an excellent job on numerous projects for the City of Sedona over the years. A few of these projects are listed below:
  - Soldier Wash Drainage Improvements Project (Phases 1, 3 and 4)
  - Brewer Road Crossing Drainage Project
  - Coffee Pot Drainage Basin Improvements Project (all four phases)
  - Juniper Hills Area Drainage Improvements Project
  - Thunder Mountain Drainage Project (aka, Harmony Phase 5)
  - Carroll Canyon Emergency Bank Protection (behind Recycles Center)



# Questions?

