

SHEET INDEX

- 1 PRELIMINARY PLAT COVER SHEET
- 2 PRELIMINARY PLAT

CHAPEL VIEW TERRACE PRELIMINARY PLAT

A SUBDIVISION OF PARCEL B, AS RECORDED IN INSTRUMENT #3686479 & INSTRUMENT #3807829, COCONINO COUNTY
 RECORDERS OFFICE LOCATED WITHIN THE NORTHWEST 1/4 OF SECTION 30, TOWNSHIP 17 NORTH, RANGE 6 EAST OF THE

GILA AND SALT RIVER BASE AND MERIDIAN,
 WITHIN THE CITY OF SEDONA, COCONINO COUNTY, ARIZONA

ORIGINAL ASSESSORS PARCEL NUMBER 401-34-033B

CONTAINING ±3.29 ACRES

ZONED SINGLE FAMILY RESIDENTIAL (RS-18)

CASE NO. _____ (SUB)

DECLARATION AND DEDICATION

KNOW ALL MEN BY THESE PRESENTS:

THAT RIFE DEVELOPMENT, LLC, A LIMITED LIABILITY CORPORATION ("TRUSTEE"), HAS SUBDIVIDED UNDER THE NAME OF "CHAPEL VIEW TERRACE", A PORTION OF THE NORTHWEST QUARTER OF SECTION 30, TOWNSHIP 17 NORTH, RANGE 6 EAST OF THE GILA AND SALT RIVER BASE AND MERIDIAN, COCONINO COUNTY ARIZONA, AS SHOWN PLATTED HEREON AND HEREBY PUBLISHES THIS PLAT AS AND FOR THE PLAT OF SAID "CHAPEL VIEW TERRACE" ("THE PLAT"). "TRUSTEE" HEREBY DECLARES THAT "THE PLAT" SETS FORTH THE LOCATION AND GIVES THE DIMENSIONS OF THE LOTS, TRACTS, STREETS, AND EASEMENTS, AND THAT EACH SHALL BE KNOWN BY THE NUMBER, LETTER, OR NAME GIVEN HEREON.

"TRUSTEE" HEREBY DECLARES THAT THE EASEMENTS SHOWN UPON THIS PLAT SHALL BE ESTABLISHED AND RESERVED IN ACCORDANCE WITH THE NOTATION ON SAID PLAT AND SHALL PROVIDE TO THE PUBLIC THE USE THEREOF FOREVER FOR INGRESS, EGRESS PURPOSES AND FOR INSTALLATION, OPERATION, AND MAINTENANCE OF PUBLIC UTILITY LINES AND FACILITIES, INCLUDING WITHOUT LIMITATION, WATER, SANITARY SEWER, ELECTRIC, NATURAL GAS, TELEPHONE, CABLE SERVICES, WATERCOURSES AND/OR DRAINAGE FACILITIES. THE "TRUSTEE" ALSO DECLARES THAT THE STREETS CONSTRUCTED AND LOCATED WITHIN THE SUBJECT EASEMENTS PROVIDING ACCESS TO, FROM AND THROUGHOUT THE SUBDIVISION SHALL REMAIN PRIVATE, AND ARE NOT DEDICATED TO THE PUBLIC BUT ARE RESERVED FOR THE USE, ENJOYMENT AND BENEFIT OF THE ADJACENT OWNERS; THE MAINTENANCE OF THE SAID STREET WILL BE THE RESPONSIBILITY OF THE INDIVIDUAL LOT OWNERS WITHIN THE SUBDIVISION.

FURTHER THE "TRUSTEE" HEREBY GRANTS TO THE CITY OF SEDONA, A MUNICIPAL CORPORATION, LICENSE TO ACCESS UPON THE ESTABLISHED EASEMENT AND STREETS PROVIDED AS DESCRIBED HEREON, FOR THE PURPOSE OF PERIODIC INSPECTION AND MAINTENANCE OF THE WATERCOURSES AND/OR DRAINAGE FACILITIES. THE MAINTENANCE OF THE DRAINAGE EASEMENTS AND FACILITIES SHALL BE THE RESPONSIBILITY OF THE INDIVIDUAL LOT OWNERS WITHIN THE SUBDIVISION.

IN WITNESS WHEREOF:

"TRUSTEE" HAS CAUSED THIS PLAT TO BE DULY EXECUTED AS OF THIS _____ DAY OF _____, 2020.

BY: _____
 TRUST OFFICER

STATE OF ARIZONA)
 COUNTY OF COCONINO)

SUBSCRIBED AND SWORN BEFORE ME ON THIS _____ DAY OF _____, 2021

BY: _____, MY COMMISSION EXPIRES _____

NOTARY PUBLIC

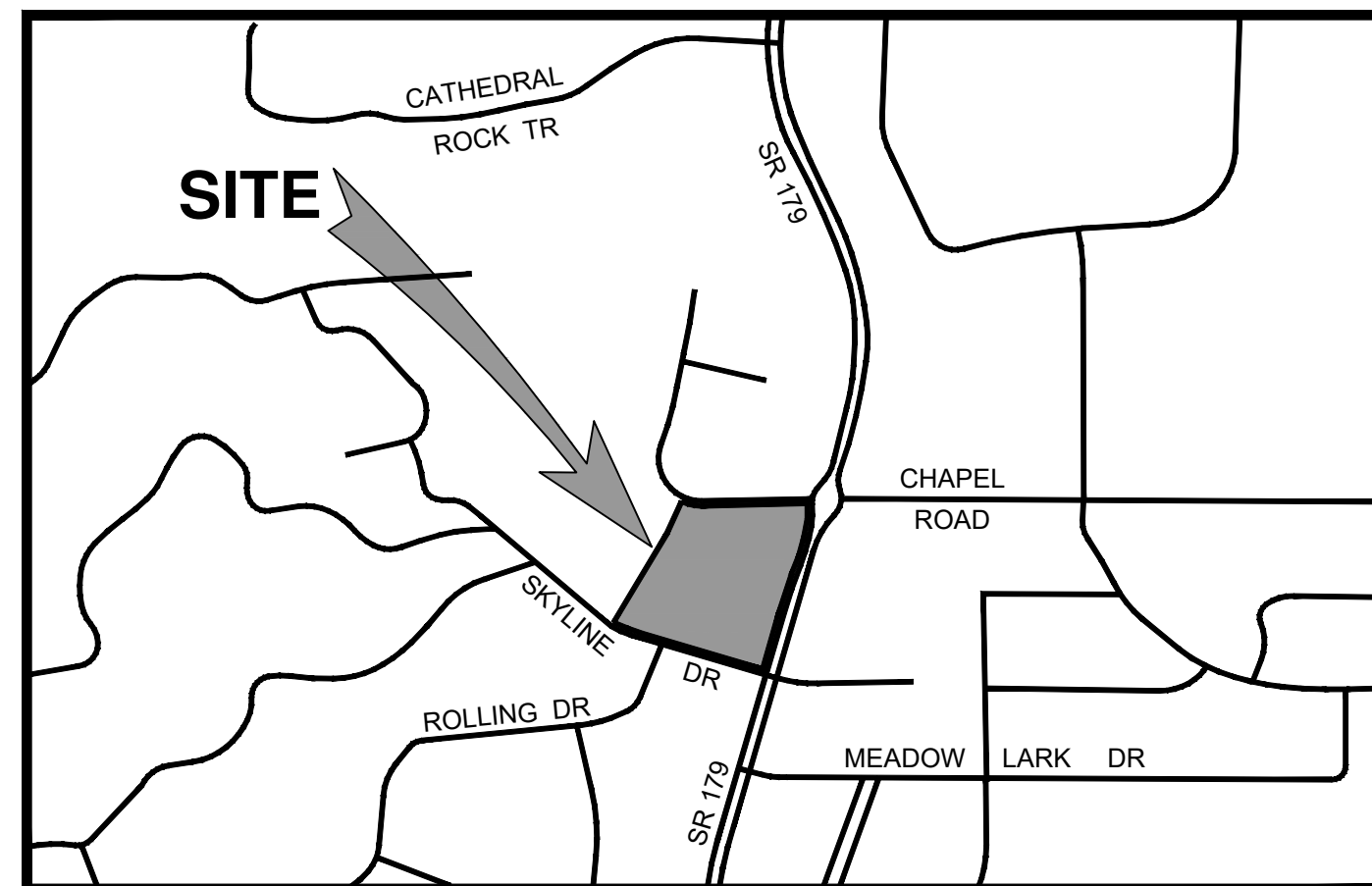

VICINITY MAP
 NOT TO SCALE

UTILITY COMPANIES

ELECTRIC: ARIZONA PUBLIC SERVICE COMPANY
 P.O. BOX 53920, STE. 9996
 PHOENIX, ARIZONA 85072-3920

WATER: ARIZONA WATER COMPANY
 3805 N. BLACK CANYON HIGHWAY
 PHOENIX, AZ 8505-5351

SEWER: CITY OF SEDONA
 PUBLIC WORKS DEPARTMENT
 102 ROADRUNNER DRIVE
 SEDONA, AZ 86336

CABLE/PHONE: CENTURYLINK
 CENTURYLINK ENGINEERING
 500 S. CALVARY WAY
 COTTONWOOD, AZ 86326

GAS: SUDDENLINK
 65 COFFEEPOT DRIVE STE. A
 SEDONA, ARIZONA 86336

GAS: UNISOOURCE ENERGY SERVICES
 P.O. BOX 80078
 PRESCOTT, AZ 86304-8078

SOLID WASTE COLLECTION: COLLECTION: PATRIOT DISPOSAL
 211 SMITH ROAD
 SEDONA, AZ 86336

DEVELOPER CONTACT INFORMATION

CHRIS RIFE
 PASSION LLC
 1300 W WATERLOO ROAD
 EDMOND, OK 73025
 (480) 734-3999

PARCEL ZONING RS-18

SINGLE FAMILY RESIDENCE
 MIN LOT SIZE = 18,000 SQ. FT.

LOTS 1 - 6
 SMALLEST LOT = 19,900 S.F. (0.46 AC)
 LARGEST LOT = 27,890 S.F. (0.64 AC)
 AVERAGE LOT SIZE = 23,890 S.F. (0.55 AC)

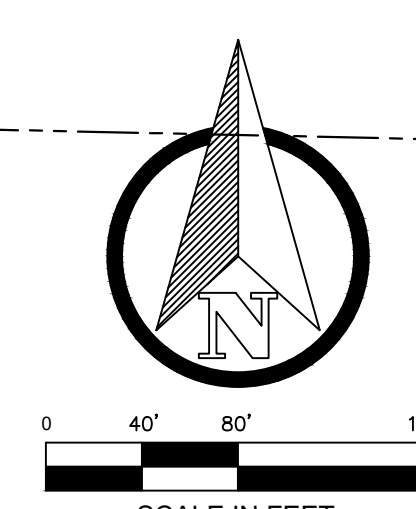

CERTIFICATE OF APPROVALS

SEDONA COMMUNITY DEVELOPMENT DEPARTMENT

DIRECTOR _____ DATE _____

SEDONA FIRE DISTRICT

FIRE MARSHAL _____ DATE _____

SEDONA PUBLIC WORKS DEPARTMENT

CITY ENGINEER _____ DATE _____

SEDONA CITY COUNCIL

MAYOR OF SEDONA _____ DATE _____

CITY CLERK _____ DATE _____

PLAT NOTES

1. NO STRUCTURE OF ANY KIND SHALL BE CONSTRUCTED OR PLACED WITHIN OR OVER ANY UTILITY EASEMENT EXCEPT WOOD, WIRE OR REMOVABLE SECTION TYPE FENCING, OR SUITABLE LANDSCAPING THAT DOES NOT INTERFERE WITH THE INTENDED PURPOSE OF THE EASEMENT.
2. NO STRUCTURE OF ANY KIND SHALL BE CONSTRUCTED OR PLACED WITHIN OR OVER THE DRAINAGE EASEMENT EXCEPT STONE, GRAVEL, OR OTHER DRAINAGE CHANNEL MATERIALS OR SUITABLE LANDSCAPING THAT DOES NOT INTERFERE WITH THE INTENDED PURPOSE OF THE EASEMENT.
3. ALL STREETS PLATTED HEREON ARE PRIVATE AND SHALL NOT BE MAINTAINED BY THE CITY OF SEDONA. STREET MAINTENANCE SHALL BE THE RESPONSIBILITY OF THE ADJACENT PROPERTY OWNERS.
4. VISIBILITY EASEMENTS SHOWN ON THE SUBDIVISION LAND DEVELOPMENT PLANS SHALL BE MAINTAINED BY THE ADJACENT PROPERTY OWNERS ON BOTH SIDES OF ENTRANCE ROAD. VEGETATION WITHIN SHALL BE PRUNED AND MAINTAINED AT A HEIGHT LESS THAN 2' TREE BRANCHES LOWER THAN 6' WITHIN THE TRIANGLES SHALL ALSO BE PRUNED.
5. FRONT PROPERTY LINES FOR LOTS 1 - 6 ARE THE CENTER LINE OF THE INGRESS/EGRESS EASEMENT.
6. ALL FRONT BUILDING SETBACKS SHALL BE MEASURED FROM THE EDGE OF THE INGRESS/EGRESS EASEMENT.
7. LOT CORNERS WITHIN THE SUBDIVISION SHALL BE SET WITHIN 90 DAYS OF THE APPROVAL AND RECORDATION OF THE FINAL PLAT AND WILL BE MONUMENTED IN ACCORDANCE WITH THE ARIZONA BOUNDARY SURVEY MINIMUM STANDARDS BY THE REGISTERED LAND SURVEYOR OF RECORD. THE MONUMENTS SHALL BE 1/2" REBARs SET WITH PLASTIC CAPS INSCRIBED WITH "LS-_____" AT EACH NEW LOT CORNER OR MISSING CORNER. ADDITIONALLY, LOT CORNERS LOCATED IN THE ROADWAY ASPHALT SHALL BE SET WITH 3" ALUMINUM CAPS INSCRIBED WITH "CITY OF SEDONA - LS-_____"
8. THE FOUND MONUMENTS SHOWN HEREON ARE FROM THE NOTES OF THE ACTUAL FIELD SURVEY CONDUCTED BY _____ RLS # _____ ON _____
9. ALL RECORDED EASEMENTS ARE SHOWN AS PART OF THESE DOCUMENTS.
10. THE WORD "CERTIFICATION", AS SHOWN HEREON, MEANS AN EXPRESSION OF PROFESSIONAL OPINION REGARDING THE FACTS DEPICTED ON THIS PLAT AND DOES NOT CONSTITUTE A WARRANT OR GUARANTEE, EITHER EXPRESSED OR IMPLIED.
11. THE LAND BEING SUBDIVIDED HEREON IS NOT WITHIN A SPECIAL FLOOD HAZARD AREA.
12. THE 15' UTILITY EASEMENT WITHIN LOT 6 IS PROVIDED FOR THE INSTALLATION OF A PRIVATE SANITARY SEWER SERVICE LINE BETWEEN APN 401-34-033A AND THE SEWER MAIN WITHIN CHAPEL ROAD.

BASIS OF BEARINGS

THE BASIS OF BEARINGS FOR THIS PLAT IS SOUTH 89 DEGREES, 10 MINUTES, 00 SECONDS, EAST (PER B.L.M. PLAT) ALONG THE NORTH LINE OF THE NORTHWEST QUARTER OF SECTION 30, TOWNSHIP 17 NORTH, RANGE 6 EAST G.&S.R.M., COCONINO COUNTY, ARIZONA.

LAND SURVEYOR CERTIFICATION

THIS FINAL PLAT AND SURVEY ON WHICH IT IS BASED WHERE CONDUCTED UNDER MY DIRECT SUPERVISION AND IS TRUE AND ACCURATE TO THE BEST OF MY KNOWLEDGE AND BELIEF. THIS MAP IS PUBLISHED SUBJECT TO ALL CONDITIONS, RESERVATIONS AND RESTRICTIONS OF THE PUBLIC RECORD ON THIS DATE.

STANLEY L. NIENHUSER RLS 29884

PRELIMINARY

SEFTON ENGINEERING CONSULTANTS

40 STUTZ BEARCAT DR.
 SEDONA, ARIZONA 86336
 PH: (928) 202-3999
 FAX: (888) 229-2970
 LS@SEFENGCO.COM

PRELIMINARY PLAT COVER SHEET

CHAPEL VIEW TERRACE

10 SKY LINE DRIVE, SEDONA, ARIZONA

SHEET TITLE:
 PROJECT TITLE:

DRAWN BY: **RJB**

SCALE: **AS NOTED**

DATE: **08/11/2021**

PROJECT NO: **210305**

SHEET NO. **1 OF 2**

© 2019, Sefton Engineering Consultants LLC, All Rights Reserved. This document is protected under the United States Copyright Act. No part may be reproduced in any form or by any means or stored in a database or retrieval system, without the prior written permission of Sefton Engineering Consultants, LLC. These plans/documents have been prepared using technical knowledge that would be applied by other qualified registrants who practice the same profession in the same area and at the same time. Efforts have been made to be as accurate as possible. However, plans/documents could contain unintentional technical inaccuracies, typographical errors or omissions. Users of these plans/documents should understand that it is highly probable that errors and omissions will occur in any plan/document preparation process, the user shall verify, and accept, the accuracy of the information.

CHAPEL VIEW TERRACE PRELIMINARY PLAT

A SUBDIVISION OF PARCEL B, AS RECORDED IN INSTRUMENT #3686479 & INSTRUMENT #3807829, COCONINO COUNTY RECORDERS OFFICE LOCATED WITHIN THE NORTHWEST 1/4 OF SECTION 30, TOWNSHIP 17 NORTH, RANGE 6 EAST OF THE GILA AND SALT RIVER BASE AND MERIDIAN, WITHIN THE CITY OF SEDONA, COCONINO COUNTY, ARIZONA ORIGINAL ASSESSORS PARCEL NUMBER 401-34-033B CONTAINING ±3.29 ACRES ZONED SINGLE FAMILY RESIDENTIAL (RS-18) CASE NO. _____ (SUB)

PRELIMINARY

SEFTON
ENGINEERING
CONSULTANTS

40 STUTZ BEARCAT DR.
SEDONA, ARIZONA 86336
PH: (928) 202-3999
FAX: (888) 229-2970
LS@SEFENCO.COM

PRELIMINARY PLAT

CHAPEL VIEW TERRACE

10 SKY LINE DRIVE, SEDONA, ARIZONA

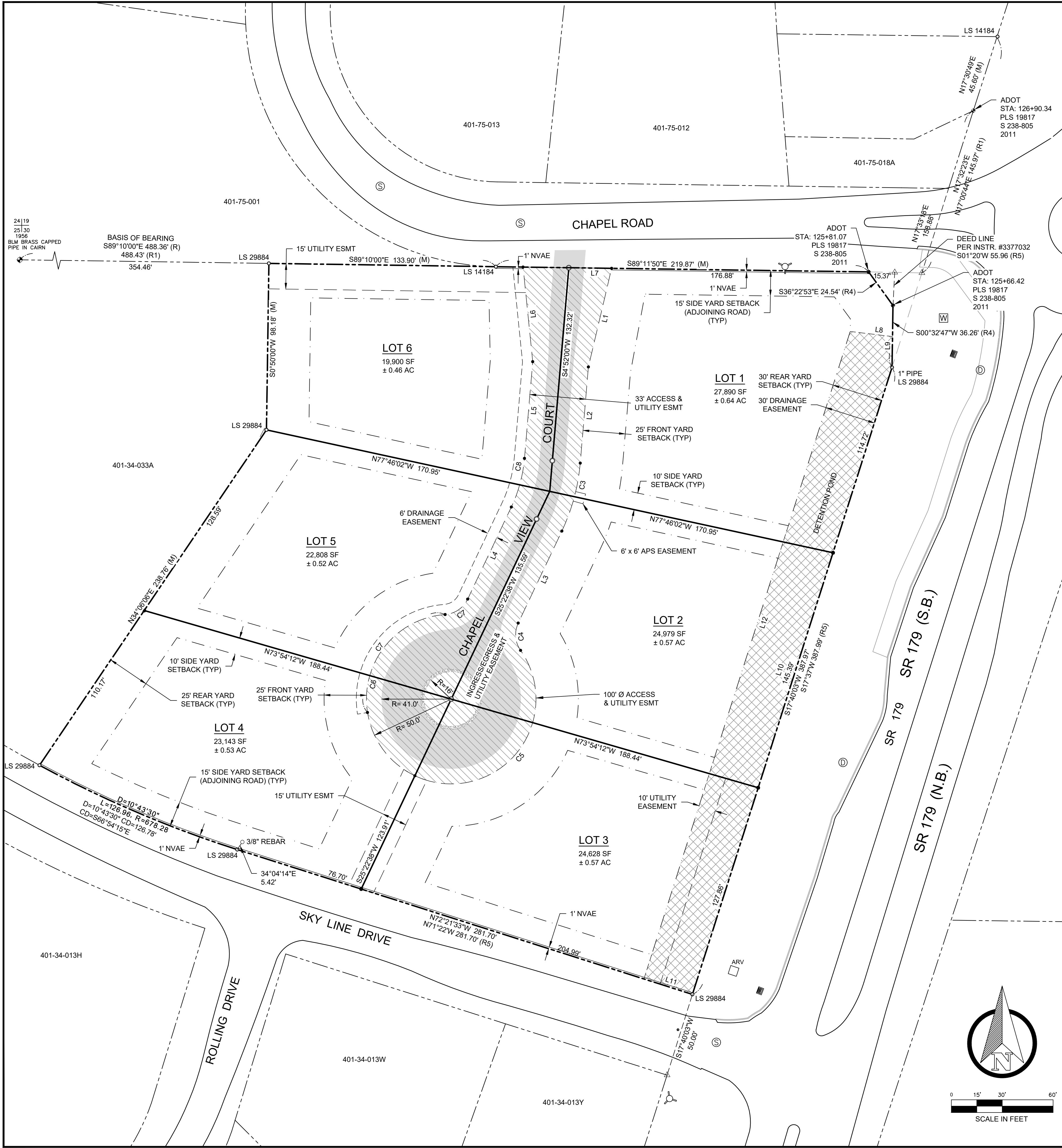

CURVE #	LENGTH	RADIUS	DELTA	CHD BEARING	CHD LEN
C1	41.70	116.50	20.51	S15° 07' 19"W	41.48
C2	16.89	16.00	60.50	S04° 52' 21"E	16.12
C3	131.34	50.00	150.50	S40° 07' 39"W	96.70
C4	131.34	50.00	150.50	N10° 37' 38"E	96.70
C5	16.89	16.00	60.50	N55° 37' 38"E	16.12
C6	29.89	83.50	20.51	N15° 07' 19"E	29.73
C7	82.86	50.00	94.96	N38° 23' 59"E	73.70

LINE #	LENGTH	DIRECTION
L1	59.73	S13° 14' 25"W
L2	56.92	S04° 52' 00"W
L3	60.05	S25° 22' 39"W
L4	60.05	N25° 22' 39"E
L5	57.23	N04° 52' 00"E
L6	56.05	N05° 48' 50"W
L7	52.22	S89° 11' 51"E

LINE #	LENGTH	DIRECTION
L8	25.14	S83° 07' 00"E
L9	18.15	S00° 53' 11"W
L10	387.97	S17° 40' 03"W
L11	24.99	N72° 21' 33"W
L12	400.66	N17° 40' 30"E

- LEGEND**
- ⊙ EXISTING SANITARY MANHOLE
 - ⊞ EXISTING WATER METER
 - ⊞ EXISTING WATER VALVE
 - ⊙ EXISTING GAS SERVICE
 - ⊞ EXISTING FIRE HYDRANT
 - ⊞ EXISTING APS TRANSFORMER
 - EASEMENT LINE
 - SUBDIVISION PERIMETER PROPERTY LINE
 - INTERIOR LOT LINE
 - ADJACENT PROPERTY LINE
 - INGRESS/EGRESS & UTILITY EASEMENT
 - DRAINAGE EASEMENT
 - NVAE: NON-VEHICULAR ACCESS EASEMENT
 - △ CALCULATED CORNER
 - ⊙ ADOT ALUMINUM CAP
 - CORNER FOUND AS INDICATED
 - (R) RECORD PER INSTRUMENT #3686479, COCONINO COUNTY RECORDER
 - (R1) RECORD PER CASE 5, MAP 49A, COCONINO COUNTY RECORDER
 - (R2) RECORD PER BOOK 5 OF MAPS & PLATS, MAP 90 YAVAPAI COUNTY RECORDER
 - (R3) RECORD PER BOOK 24, PAGE 15, COCONINO COUNTY RECORDER
 - (R4) RECORD PER ADOT DRAWING #D-13-T-457 S R 179, FEDERAL ID NO. S 238-805 SHEET P-14
 - (R5) RECORD PER INSTRUMENT #3377032, COCONINO COUNTY RECORDER
 - (R6) RECORD PER INSTRUMENT #3686479, COCONINO COUNTY RECORDER

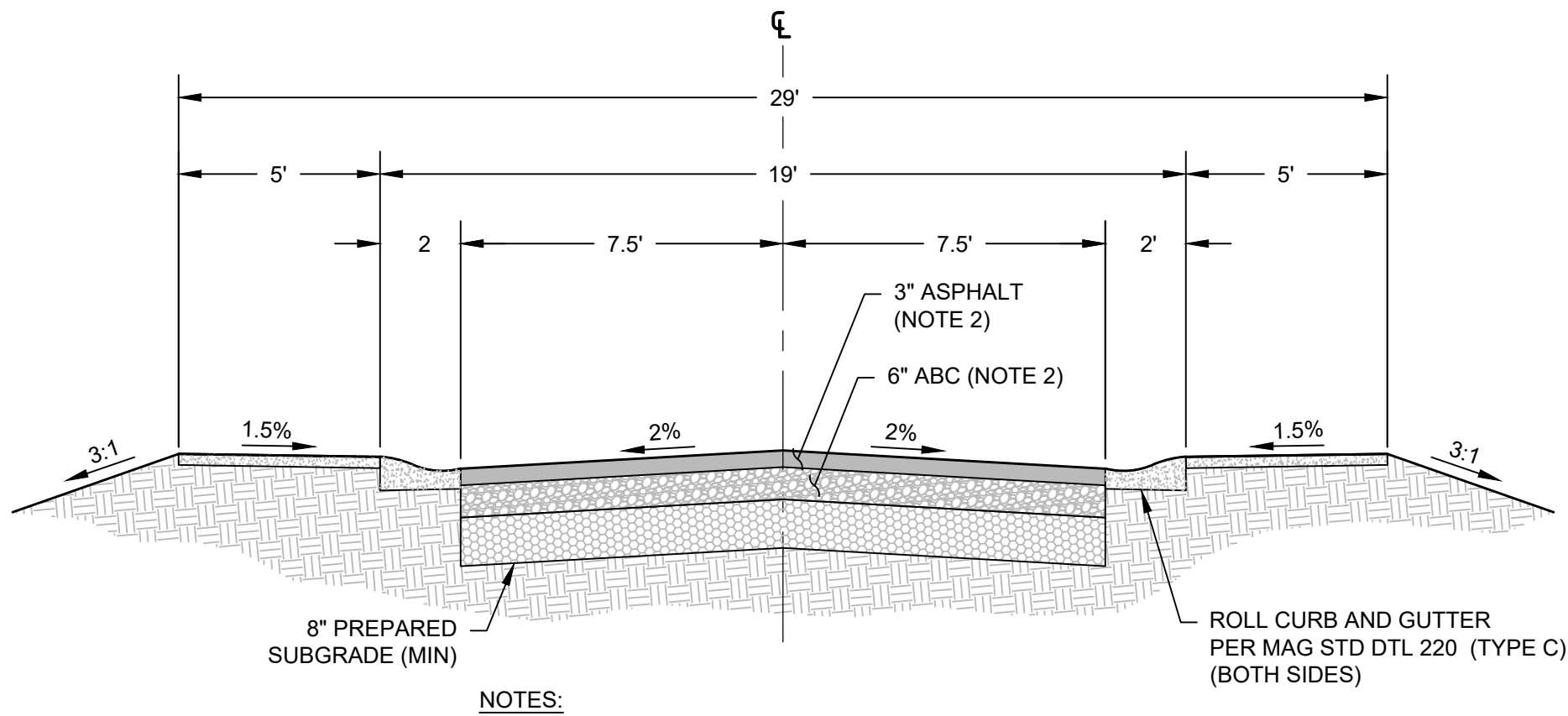

NOTES:
1) INSTALLATION, SEPARATION, AND COVER OF UTILITIES IN TRENCHES TO MEET UTILITY COMPANY STANDARDS.

TYPICAL ROAD SECTION
NOT TO SCALE

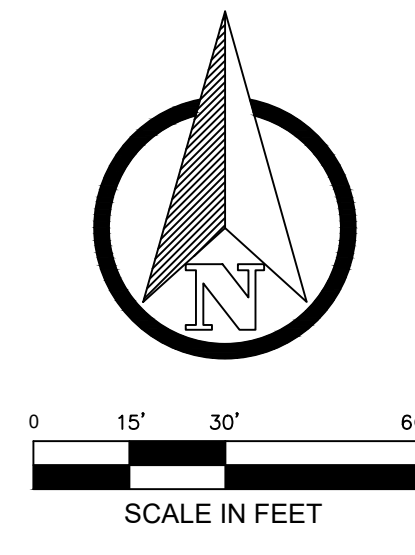

SHEET TITLE:
PROJECT TITLE:
DRAWN BY: RJB
SCALE: 1" = 30'
DATE: 08/11/2021
PROJECT NO: 210305
SHEET NO:

2 OF 2

© 2019, Sefton Engineering Consultants LLC, All Rights Reserved. This document is protected under the United States Copyright Act. No part may be reproduced in any form or by any means or stored in a database or retrieval system, without the prior written permission of Sefton Engineering Consultants, LLC. These plans/documents have been prepared using technical knowledge that would be applied by other qualified registrants who practice the same profession in the same area and at the same time. Efforts have been made to be as accurate as possible. However, plans/documents could contain unintentional technical inaccuracies, typographical errors or omissions. Users of these plans/documents should understand that it is highly probable that errors and omissions will occur in any plan/document preparation process, the user should verify the information for satisfaction.