

AGENDA



4:30 P.M.

CITY COUNCIL MEETING

TUESDAY, AUGUST 22, 2023

NOTES:

- Public Forum:
Comments are generally limited to **3 minutes**.
- Consent Items:
Items listed under Consent Items have been distributed to Council Members in advance for study and will be enacted by one motion. Any member of the Council, staff or the public may remove an item from the Consent Items for discussion. For additional information on pulling a Consent Item, please contact the City Clerk's Office staff, preferably in advance of the Call to Order. Items removed from the Consent Items may be acted upon before proceeding to the next agenda item.
- Meeting room is wheelchair accessible. American Disabilities Act (ADA) accommodations are available upon request. Please phone 928-282-3113 at least two (2) business days in advance.
- City Council Meeting Agenda Packets are available on the City's website at:

www.SedonaAZ.gov

THE MEETING CAN BE VIEWED LIVE ON THE CITY'S WEBSITE AT WWW.SEDONAAZ.GOV OR ON CABLE CHANNEL 4.

GUIDELINES FOR PUBLIC COMMENT

PURPOSE:

- To allow the public to provide input to the City Council on a particular subject scheduled on the agenda.
- This is not a question/answer session.
- No disruptive behavior or profane language will be allowed.

PROCEDURES:

- Fill out a "Comment Card" and deliver it to the City Clerk.
- When recognized, use the podium/microphone.
- State your:
 1. Name and
 2. City of Residence
- Limit comments to **3 MINUTES**.
- Submit written comments to the City Clerk.

1. CALL TO ORDER/PLEDGE OF ALLEGIANCE/MOMENT OF SILENCE

2. ROLL CALL

3. CONSENT ITEMS - APPROVE

LINK TO DOCUMENT =

- Minutes - August 8, 2023 City Council Special Meeting - Executive Session.
- Minutes - August 8, 2023 City Council Special Meeting.
- Minutes - August 8, 2023 City Council Regular Meeting.
- Minutes - August 9, 2023 City Council Special Meeting.
- AB 2984 Approval of a recommendation regarding a Series 12 Restaurant for Tortas De Fuego Mexican Food, located at 1630 SR 89A, Sedona, AZ (License # 249934).
- AB 2987 Approval of a Linking Agreement with PFM Asset Management, LLC, pursuant to the City of Mesa, Arizona's Cooperative Contract No. 2021142, for the provision of investment management services for an amount not to exceed \$225,000.00 through June 30, 2026, with the option to extend through June 30, 2028.
- AB 2989 Approval of the award of a Streets Maintenance Job Order Contract extension to Cactus Asphalt, Inc. and J. Banicki Construction, Inc.

4. APPOINTMENTS - None.

5. SUMMARY OF CURRENT EVENTS BY MAYOR/COUNCILORS/CITY MANAGER

6. PUBLIC FORUM

(This is the time for the public to comment on matters not listed on the agenda. The City Council may not discuss items that are not specifically identified on the agenda. Therefore, pursuant to A.R.S. § 38-431.01(H), action taken as a result of public comment will be limited to directing staff to study the matter, responding to any criticism, or scheduling the matter for further consideration and decision at a later date.)

7. PROCLAMATIONS, RECOGNITIONS & AWARDS

- Recognition of K9 Dalon Artwork by Robert Albrecht.

8. REGULAR BUSINESS

- AB 2985 **Public hearing/presentation/discussion** regarding the City of Sedona Development Impact Fee Audit Report for Fiscal Years 2020-21 and 2021-22.
- AB 2953 **Presentation/discussion** regarding the June 2023 Sales and Bed Tax Report.
- AB 2950 **Discussion/direction regarding** an Ordinance amending the Sedona City Code Title 10 (Vehicles and Traffic) by adding Chapter 10.30 (Improper Motor Vehicle Equipment) and a voluntary agreement with local OHV rental companies.
- AB 2986 **Discussion/possible action** regarding an Ordinance amending the Sedona City Code Title 13 (Public Services and Utilities) Division II (Storm Water) by amending Chapter 13.50 (Storm Water Discharge). (First Public Meeting).

CITY COUNCIL CHAMBERS
102 ROADRUNNER DRIVE, SEDONA, AZ

The mission of the City of Sedona government is to provide exemplary municipal services that are consistent with our values, history, culture and unique beauty.



Page 2, City Council Meeting Agenda Continued

- e. **Reports/discussion** regarding Council assignments.
- f. **Discussion/possible action** regarding future meeting/agenda items.

9. EXECUTIVE SESSION

Upon a public majority vote of the members constituting a quorum, the Council may hold an Executive Session that is not open to the public for the following purposes:

- a. To consult with legal counsel for advice on matters listed on this agenda per A.R.S. § 38-431.03(A)(3).
- b. Return to open session. Discussion/possible action on executive session items.

10. ADJOURNMENT

Posted: 8/17/23

By: DJ

JoAnne Cook, CMC, City Clerk

Note: Pursuant to A.R.S. § 38-431.02 notice is hereby given to the members of the City Council and to the general public that the Council will hold the above open meeting. Members of the City Council will attend either in person or by telephone, video, or internet communications. The Council may vote to go into executive session on any agenda item, pursuant to A.R.S. § 38-431.03(A)(3) and (4) for discussion and consultation for legal advice with the City Attorney. Because various other commissions, committees and/or boards may speak at Council meetings, notice is also given that four or more members of these other City commissions, boards, or committees may be in attendance.

A copy of the packet with materials relating to the agenda items is typically available for review by the public in the Clerk's office after 1:00 p.m. the Thursday prior to the Council meeting and on the City's website at www.SedonaAZ.gov. The Council Chambers is accessible to people with disabilities, in compliance with the Federal 504 and ADA laws. Those with needs for special typeface print, may request these at the Clerk's Office. All requests should be made **forty-eight hours** prior to the meeting.

NOTICE TO PARENTS AND LEGAL GUARDIANS: Parents and legal guardians have the right to consent before the City of Sedona makes a video or voice recording of a minor child, pursuant to A.R.S. § 1-602(A)(9). The Sedona City Council meetings are recorded and may be viewed on the City of Sedona website. If you permit your child to attend/participate in a televised City Council meeting, a recording will be made. You may exercise your right not to consent by not allowing your child to attend/participate in the meeting.

CITY COUNCIL CHAMBERS
102 ROADRUNNER DRIVE, SEDONA, AZ

**Action Minutes
Special City Council Meeting
Sedona City Hall, Vultee Conference Room
106 Roadrunner Drive, Sedona, Arizona
Tuesday, August 8, 2023, 2:00 p.m.**

1. Call to Order

Mayor Jablow called the meeting to order at 2:00 p.m.

2. Roll Call

Council Present: Mayor Scott Jablow, Vice Mayor Holli Ploog, Councilor Melissa Dunn, Councilor Brian Fultz, Councilor Pete Furman, Councilor Kathy Kinsella, and Councilor Jessica Williamson.

Staff Present item: City Attorney Kurt Christianson and City Clerk JoAnne Cook. City Manager Karen Osburn and Deputy City Manager Andy Dickey entered the meeting for item 3b at 2:40 p.m.

3. Executive Session

Motion: Councilor Kinsella moved to enter into Executive Session at 2:01 p.m. Seconded by Councilor Williamson. Motion carried unanimously with seven (7) in favor (Jablow, Ploog, Dunn, Fultz, Furman, Kinsella, and Williamson) and zero (0) opposed.

JoAnne Cook gave the admonition.

- a. **Discussion and consultation regarding personnel matters, specifically to discuss City Attorney Kurt Christianson's annual evaluation. This matter is brought in executive session pursuant to A.R.S. 38-431.03(A)(1).**

City Manager Karen Osburn and Deputy City Manager Andy Dickey entered the meeting for item 3b at 2:40 p.m.

- b. **Discussion and consultation with the City Attorney for legal advice regarding the proposed Improper Vehicle Equipment ordinance. This matter is brought in executive session pursuant to A.R.S. § 38-431.03(A)(3).**
- c. **Return to open session. Discussion/possible action regarding executive session items 3:26 p.m.**

Motion: Councilor Kinsella moved to approve the paid time off provision and to increase the City Attorney's base salary by 6%. Seconded by Councilor Dunn. Motion carried unanimously with seven (7) in favor (Jablow, Ploog, Dunn, Fultz, Furman, Kinsella, and Williamson) and zero (0) opposed.

4. Adjournment

Mayor Jablow adjourned the meeting at 3:30 p.m.

I certify that the above are the true and correct actions of the Special City Council Meeting held on August 8, 2023.

JoAnne Cook, CMC, City Clerk

Date

**Action Minutes
Special City Council Meeting
City Council Chambers, Sedona City Hall,
102 Roadrunner Drive, Sedona, Arizona
Tuesday, August 08, 2023, 4:00 p.m.**

1. Call to Order

Mayor Jablow called the meeting to order at 4:00 p.m.

2. Roll Call

Council Present: Mayor Scott Jablow, Vice Mayor Holli Ploog, Councilor Melissa Dunn, Councilor Brian Fultz, Councilor Pete Furman, Councilor Kathy Kinsella, and Councilor Jessica Williamson.

Staff Present: City Manager Karen Osburn, Deputy City Manager Andy Dickey, City Attorney Kurt Christianson, Director of Financial Services Cherie Wright, Accounting Supervisor Rene Stanley, Budget and Financial Analyst Sterling West, Assistant City Attorney Douglas Drury, Deputy City Clerk Marcy Garner, and City Clerk JoAnne Cook.

3. Special Business

a. AB 2971 Public hearing/discussion/possible action regarding approval of a Resolution adopting the City of Sedona’s Budget for Fiscal Year 2023-24.

Presentation by Cherie Wright.

Opened the public hearing at 4:16 p.m.

No comments were heard.

Closed the public hearing and brought back to Council at 4:16 p.m.

Comments from Council.

Motion: Vice Ploog moved to approve Resolution No. 2023-25 adopting the Budget for Fiscal Year 2023-24 including the budget attachments. Seconded by Councilor Williamson. Vote: Motion carried unanimously with seven (7) in favor (Jablow, Ploog, Dunn, Fultz, Furman, Kinsella, Williamson) and zero (0) opposed.

4. Executive Session

Upon a public majority vote of the members constituting a quorum, the Council may hold an Executive Session that is not open to the public for the following purposes:

- a. To consult with legal counsel for advice on matters listed on this agenda per A.R.S. § 38-431.03(A)(3).**
- b. Return to open session. Discussion/possible action on executive session items.**

No Executive Session was held.

5. Adjournment

Mayor Jablow adjourned the meeting at 4:18 p.m. without objection.

I certify that the above are the true and correct actions of the Special City Council Meeting held on August 08, 2023.

JoAnne Cook, CMC, City Clerk

Date

Action Minutes
Regular City Council Meeting
City Council Chambers, Sedona City Hall,
102 Roadrunner Drive, Sedona, Arizona
Tuesday, August 8, 2023, 4:30 p.m.

1. Call to Order/Pledge of Allegiance/Moment of Silence

Mayor Jablow called the meeting to order at 4:32 p.m.

Council Present: Mayor Scott Jablow, Vice Mayor Holli Ploog, Councilor Melissa Dunn, Councilor Brian Fultz, Councilor Pete Furman, Councilor Kathy Kinsella, and Councilor Jessica Williamson.

Staff Present: City Manager Karen Osburn, Deputy City Manager Andy Dickey, City Attorney Kurt Christianson, Chief Foley, Deputy Chief Ryan Kwitkin, Arts Coordinator Nancy Lattanzi, Director of Community Development Steve Mertes, Assistant Public Works Director and City Engineer Sandy Phillips, Facilities Maintenance Manager Larry Farhat, Principal Planner Cynthia Lovely, Parks and Recreation Manager Josh Frewin, Housing Manager Shannon Boone, Deputy City Clerk Marcy Garner, and City Clerk JoAnne Cook.

2. Roll Call/Moment of Art

Nancy Lattanzi introduced the Celebration of Life Tribute to John Soderberg. Presentation by Nancy Lattanzi, Mary Helsaple, Jill Galea, and Jill Trenholm.

The following spoke regarding John Soderberg: Nancy Rob Dunst, Sedona, Mary Byrd, Sedona, Margaret Joy Weaver, Sedona, Ernie Strauch, Sedona, Linda Goldenstein, Sedona, Frank Ferrante, Sedona, Robert Alexander, Sedona and Dale Casey, Sedona.

Break at 5:33 p.m. Reconvened at 5:38 p.m.

3. Consent Items

- a. **Minutes - July 11, 2023 City Council Special Meeting - Executive Session.**
- b. **Minutes - July 11, 2023 City Council Regular Meeting.**
- c. **AB 2972 Approval of a recommendation regarding a new Series 10 Beer and Wine Store Liquor License application for Sedona Uptown Market located at 361 Forest Road #A, Sedona, AZ (License # 238147).**
- d. **Approval of Proclamation, Child Support Awareness Month, August 2023.**

Motion: Councilor Kinsella moved to approve the consent agenda items 3a – 3d. Seconded by Councilor Williamson. Vote: Motion passed with seven (7) in favor (Jablow, Ploog, Dunn, Fultz, Furman, Kinsella, Williamson) and zero (0) opposed.

4. Appointments – None.

5. Summary of Current Events by Mayor/Councilors/City Manager

Councilor Kinsella advised that she attended a meeting of the City of Sedona’s contracted service providers that included the Sedona Humane Society, Sedona Community Center, Sedona Historical Society, Sedona Public Library, Sedona Recycling Center, and Verde

Valley Caregivers to discuss common challenges. The group will continue to meet quarterly. Vice Mayor Ploog advised the pool is still open and stated 505 children attended the swim lesson sessions. The Adult Softball League is on Thursdays at 6:15 p.m. She advised the summer camp sessions have ended. Flag Football registration is open and ends on August 13th. For online registration, visit sedonaaz.gov/sports. The Wag Fest Event will be held on September 16th and registration is open for vendors and sponsors, visit sedonaaz.gov/parks for more information on events. Mayor Jablow advised he and city manager met with David Cheney, CEO of Northern AZ Healthcare regarding healthcare services in Verde Valley. The Mayor stated that he is optimistic. Mayor Jabow stated he met with two Yavapai County Supervisors and said they are looking at the possibility of creating a regional police dispatch unit.

6. Public Forum

Opened to public at 5:48 p.m.

Madeleirie O'Callaghan, Sedona, acknowledged City Council and the City of Sedona to for their commitment to the community. She acknowledged Kathy Schriber as the founder of the Red Dirt Concerts.

John Duff, Sedona, and Seth Byerley, Sedona, spoke regarding his wildlife animal rescue stand in Uptown Sedona.

Brought back to Council at 5:56 p.m.

7. Proclamations, Recognitions & Awards

a. Child Support Awareness Month, August 2023.

Mayor Jablow presented the proclamation to Megan Zimmerman-Grande of Department of Economic Security Division of Child Support Services. Megan accepted the proclamation and thanked Council for their support.

8. Regular Business

a. AB 2980 Discussion/presentation by Ed Rose, General Manager of the Sedona Airport Administration, to provide an update to the City Council on their activities, accomplishments, and general services to the community.

Presentation by Ed Rose, General Manager of the Sedona Airport Administration.

Questions and comments from Council.

For discussion and presentation only.

b. AB 2979 Discussion/possible action regarding approval of a Resolution amending the development agreement between Sunset Lofts, LLC and the City of Sedona for the construction of 46-units of workforce housing at 220 Sunset Drive in Sedona.

Presentation by Kurt Christianson and Karen Osburn.

Questions and comments from Council.

Break at 7:10 p.m. Reconvened at 7:30 p.m.

Motion: Councilor Williamson moved to approve Resolution 2023-26 approving an amendment to the development agreement between the City of Sedona and Sunset Lofts, LLC. Seconded by Vice Mayor Ploog. Vote: Motion passed with seven (7) in favor (Jablow, Ploog, Dunn, Fultz, Furman, Kinsella, Williamson) and zero (0) opposed.

- c. AB 2982 Discussion/possible direction regarding an update of the Ranger Station Park Build Out, Capital Improvement Program Project PR-03C.**

Presentation by Sandy Phillips, Josh Frewin, Larry Farhat, and Cynthia Lovely.

Questions and comments from Council.

- d. AB 2976 Discussion/possible action regarding an Ordinance amending the Sedona City Code Title 12 (Streets, Sidewalks, and Public Places) by amending Chapter 12.05 (Rights-of-Way).**

Presentation by Kurt Christianson.

Questions and comments from Council.

(After First Read)

Motion: Councilor Williamson moved to adopt Ordinance No. 2023-05 an ordinance of the Mayor and Council of the City of Sedona, Arizona adopting amendments to the Sedona City Code Title 12 Streets, Sidewalks, and Public Places) by amending Chapter 12.05 (Rights-of-Way). Seconded by Councilor Dunn. Vote: Motion with six (6) in favor (Jablow, Ploog, Dunn, Fultz, Furman, Williamson) and one (1) opposed (Kinsella opposed).

- e. Reports/discussion regarding Council assignments.**

Councilor Furman advised that he attended the Coconino Plateau Water Partnership meeting and said Camp Verde will be joining. He said that the State of Arizona is creating a Climate Action Plan. Vice Mayor Ploog advised the Tucson News reported that Governor Hobbs is in support of cities having local control over short-term rentals.

Discussion regarding ideas for future meeting/agenda items.

Mayor advised that tomorrow's meeting will start at 2:00 p.m.

9. Executive Session

Upon a public majority vote of the members constituting a quorum, the Council may hold an Executive Session that is not open to the public for the following purposes:

- a. To consult with legal counsel for advice on matters listed on this agenda per A.R.S. § 38-431.03(A)(3).**
- b. Return to open session. Discussion/possible action on executive session items.**

No Executive Session was held.

10. Adjournment

Mayor Jablow adjourned the meeting at 8:30 p.m. without objection.

I certify that the above are the true and correct actions of the Regular City Council Meeting held on August 8, 2023.

JoAnne Cook, CMC, City Clerk

Date

Action Minutes
Special City Council Meeting
City Council Chambers, Sedona City Hall
102 Roadrunner Drive, Sedona, Arizona
Wednesday, August 9, 2023, 2:00 p.m.

1. Call to Order

Mayor Jablow called the meeting to order at 2:00 p.m.

2. Roll Call

Roll Call: Mayor Scott Jablow, Vice Mayor Holli Ploog, Councilor Melissa Dunn, Councilor Brian Fultz, Councilor Pete Furman, Councilor Kathy Kinsella, and Councilor Jessica Williamson joined via Teams.

Staff in attendance: City Manager Karen Osburn, Deputy City Manager Andy Dickey Attorney Kurt Christianson, Engineering Supervisor John Hall, Associate Engineer Bob Welch, Communications Manager Lauren Browne, Transit Administrator Robert Weber, Director of Public Works/City Engineer Kurtis Harris, Assistant Director of Public Works Sandra Phillips, City Clerk JoAnne Cook, and Deputy City Clerk Marcy Garner.

3. Special Business

a. AB 2378 Presentation/discussion/possible direction regarding the Sedona In Motion program.

1. Update on the Sedona In Motion transportation program.

Presentation by Andy Dickey, Kurtis Harris, Kimley-Horn Project Manager Andrew Baird and Associate Parking and Mobility Consultant Jeremiah Simpson.

Questions and comments from Council.

Open to the public at 4:40 p.m.

Tom Gilomen, Sedona, and Mark TenBroek, Sedona, both spoke regarding this item.

Brought back to Council at 4:47 p.m.

Council break at 4:57 p.m.

Returned to Council at 5:07 p.m.

2. Update on the progress made to date with the Uptown parking evaluation.

Presentation from Sandra Phillips and Kurtis Harris.

Questions and comments from Council.

Open to the public at 5:30 p.m.

Tracey Delaney, Sedona and Christina May, Sedona both spoke regarding this item.

Brought back to Council at 5:37p.m.

By consensus, Council directed staff to move forward with design for Andante shared use path, SIM-11n.

b. Discussion/possible action regarding future meetings/agenda items. - None

4. Executive Session

Upon a public majority vote of the members constituting a quorum, the Council may hold an Executive Session that is not open to the public for the following purposes:

- a. To consult with legal counsel for advice on matters listed on this agenda per A.R.S. § 38-431.03(A)(3).
- b. Return to open session. Discussion/possible action on executive session items.

5. Adjournment

Mayor Jablow adjourned the meeting at 5:45 p.m. without objection.

I certify that the above are the true and correct actions of the Special City Council Meeting held on August 9, 2023.

Marcy Garner, Deputy City Clerk

Date



**CITY COUNCIL
AGENDA BILL**

**AB 2984
August 22, 2023
Consent Items**

Agenda Item: 3e

Proposed Action & Subject: Approval of a recommendation regarding an application for a Series 12 Restaurant Liquor License for Tortas De Fuego Mexican Food located at 1630 AZ State Route 89A, Sedona, AZ (File# 249934).

Department	City Clerk
Time to Present	N/A
Total Time for Item	
Other Council Meetings	N/A
Exhibits	Liquor License Application is available for review in the City Clerk's office.

City Attorney Approval	Reviewed 8/15/23 KWC	Expenditure Required	
			\$ 0
City Manager's Recommendation	Recommend approval of an application for a Series 12 Restaurant Liquor License for Tortas De Fuego Mexican Food located at 1630 AZ State Route 89A, Sedona, AZ (File# 249934).	Amount Budgeted	
			\$ 0
		Account No. (Description)	N/A
		Finance Approval	<input checked="" type="checkbox"/>

SUMMARY STATEMENT

Background: State liquor laws require Sedona's City Council to forward a recommendation for approval or denial of applications for liquor licenses.

The City has received an application for a Series 12 Restaurant Liquor License for Tortas De Fuego Mexican Food located at 1630 AZ State Route 89A, Sedona, AZ (File# 249934). The liquor license application is available for review and inspection in the City Clerk's office or by email.

A Series 12 Liquor License is a non-transferable, on-sale retail privileges liquor license that allows the holder of a restaurant license to sell and serve all types of spirituous liquor solely for consumption on the premises of an establishment which derives at least forty percent (40%) of its gross revenue from the sale of food. Failure to meet the 40% food requirement may result in revocation of the license.

Community Development, Finance, the City Clerk's Office, the Sedona Police Department (SPD), and Sedona Fire District (SFD) have conducted a review of the application. No objections regarding its approval were noted.

Climate Action Plan/Sustainability Consistent: Yes - No - Not Applicable

Board/Commission Recommendation: Applicable - Not Applicable

Alternative(s): Recommend denial of a new Series 12 Restaurant Liquor License for Tortas De Fuego Mexican Food located at 1630 AZ State Route 89A, Sedona, AZ (File# 249934). Reasons for a recommendation of denial would need to be specified.

MOTION

I move to: Recommend approval of an application for a Series 12 Restaurant Liquor License for Tortas De Fuego Mexican Food located at 1630 AZ State Route 89A, Sedona, AZ (File# 249934).



**CITY COUNCIL
AGENDA BILL**

**AB 2987
August 22, 2023
Consent Items**

Agenda Item: 3f
Proposed Action & Subject: Approval of a Linking Agreement with PFM Asset Management, LLC, pursuant to the City of Mesa, Arizona’s Cooperative Contract No. 2021142, for the provision of investment management services for an amount not to exceed \$225,000.00 through June 30, 2026, with the option to extend through June 30, 2028.

Department	Financial Services
Time to Present	N/A
Total Time for Item	N/A
Other Council Meetings	N/A
Exhibits	A. Linking Agreement

City Attorney Approval	Reviewed 8/15/23 KWC	Expenditure Required
		\$ 225,000.00 (not to exceed)
City Manager’s Recommendation	Approve a Linking Agreement with PFM Asset Management, LLC.	Amount Budgeted
		\$ 50,000.00 (amount budgeted for FY 2024)
		Account No. 10-5222-01-6405 (Description) (Professional Services)
		Finance Approval <input checked="" type="checkbox"/>

SUMMARY STATEMENT

Background: The City has performed all investment management services internally. Over the past 10 years, the City’s investment portfolio has increase from \$42 million to \$81 million. With a large investment portfolio and limited internal staffing capacity, professional investment advisory services are prudent and anticipated to improve returns on the City’s portfolio. A Decision Package for professional investment advisory services was presented to Council and approved during the FY 2024 budget process.

PFM Asset Management, LLC (PFM) has been an advisor to public and non-profit sector clients for more than 40 years. Some Council members have requested establishing investment policies based on environmental sustainability goals. PFM has experience with development of customizable and flexible environmental, social, and governance (ESG) investment programs tailored to meet a client’s sustainable investment goals. If this agreement is approved, PFM staff will meet with Council in a work session to help identify goals and policies decisions for investment of City monies.

This request is to approve a linking agreement to piggyback on the City of Mesa's contract with PFM. The amount budgeted for FY 2024 represents an estimate of the advisory fees, which are calculated based on the dollar amount of assets managed. The contract not-to-exceed amount is based on an estimation that the portfolio will continue to grow in future years.

Climate Action Plan/Sustainability Consistent: Yes - No - Not Applicable

Board/Commission Recommendation: Applicable - Not Applicable

Alternative(s): Continue to manage investments internally or direct staff to pursue another investment advisory firm.

MOTION

I move to: approve a Linking Agreement with PFM Asset Management, LLC, pursuant to the City of Mesa, Arizona's Cooperative Contract No. 2021142, for the provision of investment management services for an amount not to exceed \$225,000.00 through June 30, 2026, with the option to extend through June 30, 2028.

**LINKING
AGREEMENT
BETWEEN
THE CITY OF SEDONA, ARIZONA
AND
PFM ASSET MANAGEMENT, LLC**

THIS LINKING AGREEMENT (this “Agreement”) is entered into as of this 22nd day of August, 2023 (the “Effective Date”), between the **City of Sedona**, an Arizona municipal corporation (the “City”), and **PFM Asset Management, LLC**, a Delaware limited liability company (“Contractor”), collectively, the “Parties.”

RECITALS

- A. On June 23, 2021, the City of Mesa, entered into a contract with Contractor to purchase the goods and services described in the **Investment Management Services, Contract No. 2021142, from Solicitation No. 2021142** (“Cooperative Purchasing Agreement”), which is attached hereto as **Exhibit A**. The Cooperative Purchasing Agreement permits its cooperative use by other governmental agencies including the City.
- B. Sedona City Code (SCC) Section 3.05.020.C. permits the City to procure goods and services without the formal bidding process by participating with other governmental units in cooperative purchasing agreements when the best interests of the City would be served.
- C. The City desires to contract with Contractor for supplies or services identical, or nearly identical, to the supplies or services Contractor is providing other units of government under the Cooperative Purchasing Agreement. Contractor consents to the City’s utilization of the Cooperative Purchasing Agreement as the basis of this Agreement, and Contractor desires to enter into this Agreement to provide the supplies and services set forth in this Agreement.

AGREEMENT

NOW, THEREFORE, in consideration of the foregoing recitals, which are incorporated by reference, and the covenants and promises contained in this Linking Agreement, the parties agree as follows:

- 1. Term of Agreement. The City is purchasing supplies and/or services from Contractor pursuant to the Cooperative Purchasing Agreement. According to the Cooperative Purchasing Agreement, purchases can be made by governmental entities from the date of award, which was July 1, 2021, until the date the contract expires on June 30, 2026, unless the term of the Cooperative Purchasing Agreement is extended by the mutual agreement of the original contracting parties. The Cooperative Purchasing Agreement, however, may not be extended beyond June 30, 2028. The initial period of this Agreement, therefore, is the period from the **Effective Date of this Agreement until June 30, 2026, or at such time as the work in the Scope of Work is completed, whichever occurs first**. Renewals of this Agreement are not automatic and shall only occur if the City gives the Contractor notice of its intent to renew. The City may give the Contractor notice of its intent to renew this Agreement 30 days prior to the anniversary of the Effective Date to effectuate such renewal.

2. Scope of Work; Terms, Conditions, and Specifications.

- A. Contractor shall provide City the supplies and/or services identified in the Scope of Work attached as **Exhibit B**.
- B. Contractor agrees to comply with all the terms, conditions, and specifications of the Cooperative Purchasing Agreement. Such terms, conditions, and specifications are specifically incorporated into and are an enforceable part of this Agreement except as otherwise provided herein. In the event of any inconsistency or conflict between this Agreement, the Cooperative Purchasing Agreement, and any other document or Agreement between the parties with respect to the subject matter hereof, the terms and conditions of this Agreement shall prevail and govern to the extent necessary to remedy such inconsistency or conflict.

3. Compensation.

- A. City shall pay Contractor compensation at the same rate and on the same schedule as provided in the Cooperative Purchasing Agreement attached hereto as **Exhibit A**.
- B. The total purchase price for the supplies and/or services purchased under this Agreement shall not exceed **Two Hundred Twenty-Five Thousand Dollars (\$225,000.00)**.
- C. Invoices are due and payable upon receipt and are delinquent only thirty (30) days after the date received by the City. Each invoice shall set forth a general description of the work performed, in accordance with the scope of work, for the items billed.

4. Cancellation; Termination. This Agreement may be cancelled pursuant to A.R.S. § 38-511. Either party may voluntarily terminate and cancel this Agreement effective upon the expiration of thirty (30) calendar days-notice provided to the other.

5. Non-discrimination. Contractor must not discriminate against any employee or applicant for employment on the basis of race, color, religion, sex, national origin, age, marital status, sexual orientation, gender identity or expression, genetic characteristics, familial status, U.S. military veteran status or any disability. Contractor will require any Sub-contractor to be bound to the same requirements as stated within this section. Contractor, and on behalf of any subcontractors, warrants compliance with this section.

6. Insurance. The Contractor agrees to procure and maintain in force during the term of this Agreement, at its own cost, the following coverages as required by the City prior to commencement of work. The Contractor shall submit to the City before any work is performed, certificates of insurance from the Contractor's insurance carriers indicating the presence of coverages and limits of liability as follows:

- A. Commercial General Liability Insurance (Occurrence Form) with minimum combined single limits of ONE MILLION DOLLARS (\$1,000,000.00) each occurrence and TWO MILLION DOLLARS (\$2,000,000.00) general aggregate. **This policy shall include an Additional Insured endorsement.**
- B. Worker's Compensation Insurance:

- Coverage A: Statutory benefits as required by the Labor Code of the State of Arizona.
 - Coverage B: Employer's Liability
 - Bodily Injury by accident \$1,000,000.00 each accident
 - Bodily Injury by disease \$1,000,000.00 policy limit
 - Bodily Injury by disease \$1,000,000.00 each employee
- C. Automobile Liability Insurance with minimum combined single limits for bodily injury and property damage of not less than ONE MILLION DOLLARS (\$1,000,000.00) for any one occurrence, with respect to each of the Contractor's owned, hired or non-owned automobiles assigned to or used in the performance of the Services. Certificate to reflect coverage for "Any Auto, All Owned, Scheduled, Hired or Non-Owned."

A Certificate of Insurance shall be completed by the Contractor's insurance agent(s) as evidence that policies providing the required coverages, conditions, and minimum limits are in full force and effect, and shall be subject to review and approval by the City. The Certificate shall identify this Contractor and shall provide coverages afforded under the policies shall not be cancelled, terminated, or limits reduced until at least thirty (30) days prior written notice has been given to the City. The completed Certificate of Insurance shall be sent to:

City of Sedona
 102 Roadrunner Drive
 Sedona, AZ 86336
 ATTN: City Clerk

Failure on the part of the Contractor to procure or maintain policies providing the required coverages, conditions, and minimum limits shall constitute a Material Breach of this Agreement upon which the City may immediately terminate this Agreement.

All policies shall provide primary coverage and **waivers of subrogation by endorsement** or otherwise. A waiver of subrogation shall be effective as to any person or entity even though that person or entity would otherwise have a duty of indemnification, contractual or otherwise, did not pay for the insurance premium directly or indirectly and whether or not the person or entity had an insurable interest in the property damaged.

7. E-verify. Contractor agrees to comply with all federal and state immigration laws including but not limited to A.R.S. § 23-214 and A.R.S. § 41-4401.
8. No Boycott of Israel or Use of Forced Labor of Ethnic Uyghurs in People's Republic of China. As applicable, Contractor certifies and agrees it is not currently engaged in and for the duration of the Agreement will not engage in a boycott of Israel, as that term is defined in A.R.S. §35-393 and will not use forced labor or goods or services produced by forced labor of ethnic Uyghurs in the People's Republic of China (PRC) or any contractors, subcontractors or suppliers that use forced labor or goods or services produced by forced labor of ethnic Uyghurs in the PRC as provided by A.R.S. §35-394.
9. Appropriation of Funds. Every payment obligation of the CITY under this Agreement is conditioned upon the availability of funds appropriated or allocated for payment of such obligation. If funds are not allocated and available for the continuance of this Agreement, this

Agreement may be terminated by the CITY at the end of the period for which funds are available. No liability shall accrue to the CITY in the event this provision is exercised, and CITY shall not be obligated or liable for any future payments or for any damages resulting from termination under this provision.

10. Venue; Jurisdiction. This Agreement shall be governed by the laws of the State of Arizona, and any legal action concerning the provisions hereof shall be brought in the County of Yavapai, State of Arizona.
11. Attestation of PCI Compliance. When applicable, the Contractor will provide the City annually, with a Payment Card Industry Data Security Standard (PCI DSS) attestation of compliance certificate signed by an officer of Contractor, with oversight responsibility.
12. Notices. Any notices that must be provided under this Agreement shall be sent to the Parties' respective authorized representatives at the address listed below:

City of Sedona

c/o Heidi Weber
102 Roadrunner Drive
Sedona, Arizona 86336
Phone: (928) 203-5040
Email: HWeber@sedonaaz.gov

And

PFM Asset Management, LLC

c/o Annette Gaston
1820 East Ray Road
Chandler, Arizona 85225
Phone: (855) 885-9621
Email: GastonA@pfmam.com

(Signatures to follow on next page.)

IN WITNESS WHEREOF, the parties hereto have executed this Agreement as of the date and year set forth above.

CONTRACTOR:

PFM ASSET MANAGEMENT, LLC,
a Delaware limited liability company

By _____

Its _____

Date _____

CITY:

CITY OF SEDONA, a municipal
corporation of the State of Arizona

Karen Osburn, City Manager

Date _____

ATTEST:

By: _____
JoAnne Cook, City Clerk

APPROVED AS TO FORM:

By: _____
Kurt W. Christianson, City Attorney

**LINKING AGREEMENT
BETWEEN
THE CITY OF SEDONA, ARIZONA
AND
PFM ASSET MANAGEMENT, LLC**

**EXHIBIT A
Cooperative Purchasing Agreement**

(City of Mesa, Arizona, Investment Management Services, Contract No. 2021142, from Solicitation No. 2021142.)

**LINKING AGREEMENT
BETWEEN
THE CITY OF SEDONA, ARIZONA
AND
PFM ASSET MANAGEMENT, LLC**

**EXHIBIT B
Scope of Work**

Contractor will provide the City with investment management services as defined in the City of Mesa, Investment Management Services, Contract No. 2021142, from Solicitation No. 2021142, and in accordance with Fee Schedule A as stated in Exhibit B of Contract No. 2021142.

The City of Sedona's project-specific Scope of Work is as follows:

1. **INTENT:** Contractor shall assist City financial staff in the process of responsibly investing City resources. Contractor to assist the City in the management of its approximately \$80 million investment portfolio. The Contractor will directly manage only a portion of the City investment portfolio.

Contractor shall be registered with the Securities and Exchange Commission (SEC) under the Investment Advisers Act of 1940 who will act in a fiduciary capacity and present performance numbers in accordance with the CFA Institute's Global Investment Performance Standards "GIPS." The Contractor will be required to manage the funds in accordance with the laws of the State of Arizona, the City's Investment Policy, and other investment policies and procedures established by City.

2. **SCOPE OF WORK:** Specific responsibilities of the Investment Firm shall include, but not be limited to the following:
 - a. Contractor, and its affiliates, will be restricted from selling to City, or buying from the City, any securities to or from that Firm's own inventory or account. The Contractor shall act solely in a fiduciary capacity and shall not receive any fee or compensation based upon the purchase or sale of securities but, rather, the Contractor will be compensated pursuant to the provision of its contract with the City.
 - b. Contractor shall directly manage, on a daily basis, a portion of the City's investment portfolio pursuant to specific, stated investment objectives. Contractor shall place orders for the purchase and sale of securities, communicate settlement information to City's staff, and coordinate security settlement. The City anticipates managing a portion of its investment portfolio internally in State of Arizona Local Government Investment Pool (LGIP) accounts. The Contractor would not invest in LGIP accounts. The Contractor will invest in other eligible securities such as US Treasury securities; US Government Sponsored Enterprise (GSE) bullets, callables, and discount notes; corporates; negotiable certificates of deposit; GSE-backed mortgage products; taxable municipals; etc. Contractor may invest in other securities such as asset-backed securities, supranationals, etc. as may be permitted by the City. It is anticipated that the portion of the City's portfolio directly invested by the Contractor would span the full permitted investment

- horizon.
- c. Contractor shall serve as a general resource to City staff for information, advice, and training regarding investments and assistance with revisions to the City’s investment policy.
 - d. Contractor shall provide monthly statements for the portion of the portfolio managed by the Firm with all the information required by Governmental Accounting Standards Board (GASB). These reports must include a market valuation for the securities managed by the Contractor. The Contractor must maintain accurate reports of investments including the diversity of investments and compliance with applicable investment policies of the City as well as Arizona Revised Statutes.
 - e. Contractor shall provide the City with monthly investment reports including an economic update and description of market conditions, investment strategies employed, performance, and suggested changes to investment strategy. The performance numbers shall be presented as required by the CFA Institute’s Global Investment Performance Standards (GIPS).
 - f. Contractor WILL NOT provide custodial services or security safekeeping.

Fee Schedule A as stated in Exhibit B of Contract No. 2021142 is as follows:

Assets Under Management (AUM)	Standard Fee in Basis Points (“bps”)
First \$100 million	10 bps (0.10%)
Next \$100 million	7 bps (0.07%)
Assets in excess of \$200 million	6 bps (0.06%)

The City will be billed monthly in arrears based on the monthly average of AUM, which includes amortized cost of securities, accrued interest, and custody cash balances for the month. **The minimum annual fee for management is \$25,000.00.**



**CITY COUNCIL
AGENDA BILL**

**AB 2989
August 22, 2023
Consent Agenda**

Agenda Item: 3g
Proposed Action & Subject: Approval of the award of a Streets Maintenance Job Order Contract extension to Cactus Asphalt, Inc. and J. Banicki Construction, Inc.

Department	Public Works
Time to Present	NA
Total Time for Item	NA
Other Council Meetings	April 27, 2021, July 27, 2021, September 13, 2022
Exhibits	A. Cactus Unit Prices B. Banicki Unit Prices

City Attorney Approval	Reviewed 8/15/23 KWC	Expenditure Required	
		\$ 1,300,000	
City Manager's Recommendation	Approve award of a Streets Maintenance Job Order Contract extension to Cactus Asphalt, Inc. and J. Banicki Construction, Inc.	Amount Budgeted	
		\$ 1,300,000	
		Account No. 11-5320-39-6770 (Description) HURF Streets Rehab/Preservation	
		Finance Approval <input checked="" type="checkbox"/>	

SUMMARY STATEMENT

Staff is requesting approval of a Job Order Contract (JOC) extension with Cactus Asphalt, Inc. (Cactus), and J. Banicki Construction, Inc. (Banicki), for street maintenance projects. These projects will primarily include annually programmed pavement preservation and road rehabilitation, but may also include general right-of-way maintenance and asset preservation such as crack fill and seal coating on roads that are currently in above-average condition.

Background: Cactus and Banicki were selected through a qualifications and unit price proposal process and were awarded the initial JOC on April 27, 2021. The JOC is a one-year contract renewable for up to four additional one-year periods. This will be the fourth of a possible four extensions. The maximum amount for each contract will be \$1M per year. Work will be divided between the two contractors based on performance and pricing. The option to extend the contract is exercised based on the contractors' successful performance and the needs of the City.

During FY 23 Cactus completed Fractured Aggregate Surface Treatments (FAST) in the following neighborhoods Crimson View, Northern Shadows, Red Rock Heights, Valley

Shadows Unit II, Coffee Pot, Western Hills Units 1-3, Kinsey Estates Unit 1-2, Manzanita Hills Unit 1-2, and Anasazi subdivisions.

FY 24 work is expected to include the Thunderbird Hills Unit 1, 2 & 3 (TBH), TBH East, TBH East Unit 2, TBH South & Unit 2, Sedona Meadows, Sedona Meadows Unit 2 subdivisions as well as the public portion of Oak Creek Cliffs Drive.

The city has worked with Cactus for the past 8 years as they were awarded a JOC in 2015. Staff has been generally satisfied with their work. At times there have been issues with their performance, but they have revised the way they manage individual projects to ensure there is a single point of contact (Project Supervisor) that oversees all aspects of the work. While there is still room for improvement, this has resulted in better communication and better results.

Banicki has completed multiple successful projects for the city, most recent jobs include the resurfacing of Rodeo Road, Hozoni Drive, Upper Red Rock Loop Road, Sombart Lane, and Kallof Place. Banicki's performance on these projects has been excellent.

Staff is therefore requesting approval of an extension to both JOC's for Cactus and Banicki.

Climate Action Plan/Sustainability Consistent: Yes - No - Not Applicable

A strategy in the Climate Action Plan is to divert waste from the landfill and reduce Greenhouse Gas (GHG) emissions associated with consumption of goods and services. A part of the pavement program includes milling (grinding) asphalt into reusable gravel-like material (millings). The Public Works department takes this material annually, from the paving process, and stores it until it is used on future projects.

Another part of the paving program that includes diverting waste from the landfill is the process of applying FAST. Rather than tearing up the old asphalt surface, a layer of asphalt rubber and rock is applied to the surface of the street to provide a protective layer. This method is much more cost efficient, uses less material, and results in less waste, as compared to a "mill and fill" procedure.

Board/Commission Recommendation: Applicable - Not Applicable

Alternative(s):

- 1) Re-advertise for JOC contractor selection.
- 2) Advertise the projects through public bid process and risk awarding to a less qualified contractor.

MOTION

I move to: approve award of a Streets Maintenance Job Order Contract extension to Cactus Asphalt, Inc. and J. Banicki Construction, Inc.

Cactus Asphalt

City of Sedona Street Maintenance Projects - JOC Unit Prices



Item #	Description	Unit	Unit Price
1	Reset Manhole Frame And Lid	EACH	\$623.12
2	Reset Sewer Cleanout	EACH	\$480.70
3	Reset Water Valve Frame And Lid	EACH	\$480.70
4	Aggregate Base Course (0-100 TN)	TON	\$66.77
4a	Aggregate Base Course (100+ TN)	TON	\$37.70
5	Aggregate Base Course (Recondition) (0-300 SY)	SY	\$11.30
5a	Aggregate Base Course (Recondition) (300+ SY)	SY	\$1.51
6	Subgrade Prep (0-300 SY)	SY	\$11.30
6a	Subgrade Prep (300+ SY)	SY	\$1.61
7	Recondition Shoulder (0-300 SY)	SY	\$8.07
7a	Recondition Shoulder (300+ SY)	SY	\$1.51
8	PMM Seal Coat (0-1,000 SY)	SY	\$3.22
8a	PMM Seal Coat (1001-10000 SY)	SY	\$2.03
8b	PMM Seal Coat (10000-50000 SY)	SY	\$1.65
8c	PMM Seal Coat (50000+ SY)	SY	\$1.65
9	Crack Seal Roadway (0-0.5" Wide) (Min 5,000 LF)	LF	\$0.33
9a	Crack Seal Roadway (.5-1" Wide) (Min 5,000 LF)	LF	\$0.42
10	Asphaltic Concrete Pavement Milling (0 IN. To 3 IN.) (0-4000 SY)	SY	\$4.00
10a	Asphaltic Concrete Pavement Milling (0 IN. To 3 IN.) (4000+ SY)	SY	\$3.43
11	Asphaltic Concrete Pavement (0 IN. To 3 IN.)(0-100 TN)	TON	\$172.24
11a	Asphaltic Concrete Pavement (0 IN. To 3 IN.) (100+ TN)	TON	\$124.10
12	Asphaltic Concrete Pavement (> 3 IN.) (0-100 TN)	TON	\$172.24
12a	Asphaltic Concrete Pavement (> 3 IN.) (100+ TN)	TON	\$125.17
13	Asphaltic Concrete (Permanent Patch)	TON	\$230.53
14	Asphaltic Concrete Termination MAG Detail 201 Type "A" (0-100 LF)	LF	\$7.00
14a	Asphaltic Concrete Termination MAG Detail 201 Type "A" (100+ LF)	LF	\$5.92
15	Asphaltic Concrete Termination MAG Detail 201 Type "B" (0-100 LF)	LF	\$7.27
15a	Asphaltic Concrete Termination MAG Detail 201 Type "B" (100+ LF)	LF	\$6.19
16	Asphaltic Concrete Driveway MAG Detail 205	TON	\$192.85
17	Asphaltic Concrete Edge Repair (0-100 TN)	TON	\$268.21
17a	Asphaltic Concrete Edge Repair (100+ TN)	TON	\$241.29
18	Asphaltic Concrete Removal (2-4")(0-100 SY)	SY	\$28.83
18a	Asphaltic Concrete Removal (2-4")(100+SY)	SY	\$7.31
18b	Asphaltic Concrete Removal(5-6")(0-100 SY)	SY	\$34.75
18c	Asphaltic Concrete Removal(5-6")(100+ SY)	SY	\$10.96
19	Saw Cut Asphaltic Concrete Pavement (2-4")(0-100 LF)	LF	\$4.31
19a	Saw Cut Asphaltic Concrete Pavement(2-4")(100+ LF)	LF	\$1.61
19b	Saw Cut Asphaltic Concrete Pavement(5-6")(0-100 LF)	LF	\$6.46
19c	Saw Cut Asphaltic Concrete Pavement(5-6")(100+ LF)	LF	\$2.15
20	4" Pavement Markings (0-100 LF)	LF	\$2.92
20a	4" Pavement Markings (100+ LF)	LF	\$0.15

21	12" Turn Lane Markings (0-100 LF)	LF	\$3.70
21a	12" Turn Lane Markings (100 + LF)	LF	\$0.43
22	12" Crosswalk Markings (0-100 LF)	LF	\$5.25
22a	12" Crosswalk Markings (100+ LF)	LF	\$2.92
23	Concrete Handicap Ramp (0-3)	EACH	\$4,405.15
23a	Concrete Handicap Ramp (4+)	EACH	\$3,328.65
24	Concrete Sidewalk (4 IN.) New (0-20 SY)	SY	\$181.61
24a	Concrete Sidewalk (4 IN.) New (20-200 SY)	SY	\$67.98
24b	Concrete Sidewalk (4 IN.) New (200 + SY)	SY	\$62.58
25	Concrete Sidewalk (6 IN.) (New W/ Fiber Reinforcement) (0-20 SY)	SY	\$186.30
25a	Concrete Sidewalk (6 IN.) (New W/ Fiber Reinforcement) (20-200 SY)	SY	\$99.91
25b	Concrete Sidewalk (6 IN.) (New W/ Fiber Reinforcement) (200+ SY)	SY	\$94.52
26	Concrete Driveway (6 IN.) (New W/ Fiber Reinforcement)(0-20 SY)	SY	\$191.68
26a	Concrete Driveway (6 IN.) (New W/ Fiber Reinforcement)(20+ SY)	SY	\$109.62
27	Concrete Curb & Gutter (MAG Type "A", 6 IN.) (Replace) (0-20 LF)	LF	\$178.83
27a	Concrete Curb & Gutter (MAG Type "A", 6 IN.) (Replace) (20-200 LF)	LF	\$52.88
27b	Concrete Curb & Gutter (MAG Type "A", 6 IN.) (Replace) (200 + LF)	LF	\$44.23
28	Concrete Curb (MAG Type "B") (Replace) (0-20 LF)	LF	\$189.59
28a	Concrete Curb (MAG Type "B") (Replace) (20-200 LF)	LF	\$52.88
28b	Concrete Curb (MAG Type "B") (Replace) (200 + LF)	LF	\$44.23
29	Concrete Curb & Gutter (MAG Type "C") (Replace) (0-20 LF)	LF	\$168.06
29a	Concrete Curb & Gutter (MAG Type "C") (Replace) (20-200 LF)	LF	\$53.95
29b	Concrete Curb & Gutter (MAG Type "C") (Replace) (200 + LF)	LF	\$44.23
30	Concrete Sidewalk (4 IN.) (Replace) (0-20 SY)	SY	\$208.49
30a	Concrete Sidewalk (4 IN.) (Replace) (0-200 SY)	SY	\$102.41
30b	Concrete Sidewalk (4 IN.) (Replace) (200 + SY)	SY	\$92.72
31	Concrete Curb & Gutter (MAG Type "A", 6 IN.) (New) (0-20 LF)	LF	\$136.84
31a	Concrete Curb & Gutter (MAG Type "A", 6 IN.) (New) (20-200 LF)	LF	\$42.03
31b	Concrete Curb & Gutter (MAG Type "A", 6 IN.) (New) (200 + LF)	LF	\$35.60
32	Concrete Curb (MAG Type "B") (New) (0-20 LF)	LF	\$137.92
32a	Concrete Curb (MAG Type "B") (New)(20-200 LF)	LF	\$42.07
32b	Concrete Curb (MAG Type "B") (New)(200+ LF)	LF	\$36.75
33	Concrete Curb & Gutter (MAG Type "C") (New)(0-20 LF)	LF	\$139.00
33a	Concrete Curb & Gutter (MAG Type "C") (New)(20-200 LF)	LF	\$42.11
33b	Concrete Curb & Gutter (MAG Type "C") (New)(200 + LF)	LF	\$35.60
34	Sedona Red Concrete Color	CY	\$85.29
35	Tree Removal 12 IN. To 24. IN Dia	EACH	\$1,076.50
36	Street Sweeping (Power Broom)	HR	\$135.00
37	Sidewalk Sweeping (Manual)	HR	\$86.12
38	Sidewalk Sweeping (Power Broom)	HR	\$107.65
39	One (1) Sack ABC Slurry(0-10 CY)	CY	\$271.11
39a	One (1) Sack ABC Slurry (10+ CY)	CY	\$174.22
40	Core Sampling	EACH	\$250.00
41	Storm Water Pollution Prevention (Percentage Of Overall Work Order) - 2%	LS	\$0.00
42	Mobilization (Percentage Of Overall Work Order) - 10%	LS	\$0.00
43	Quality Control & Testing (Percentage Of Overall Work Order) - 3%	LS	\$0.00
44	Construction Staking	HR	\$225.00

45	Utility Potholing	HR	\$375.00
46	Tack Coat (0-300 SY)	SY	\$1.57
46a	Tach Coat (300 + SY)	SY	\$0.52
47	Asphaltic Concrete Pulverizing (2-4")(0-1000 SY)	SY	\$5.34
47a	Asphaltic Concrete Pulverizing (2-4")(1000+ SY)	SY	\$3.27
47b	Asphaltic Concrete Pulverizing (5-6")(0-1000 SY)	SY	\$5.84
47c	Asphaltic Concrete Pulverizing (5-6")(1000+ SY)	SY	\$3.77
48	Dual Layer Weed Barrier	SY	\$10.77
49	Liquid Road Seal Coat (0-1000 SY)	SY	\$5.33
49a	Liquid Road Seal Coat (1000-10000 SY)	SY	\$3.62
49b	Liquid Road Seal Coat (10000-50000 SY)	SY	\$3.10
49c	Liquid Road Seal Coat (50000+SY)	SY	\$2.96
50	Fractured Aggregate Surface Treatment (F.A.S.T.) - 0-1000 SY	SY	\$25.83
50a	Fractured Aggregate Surface Treatment (F.A.S.T.) - 1000-10000 SY	SY	\$6.64
50b	Fractured Aggregate Surface Treatment (F.A.S.T.) - 10000-50000 SY	SY	\$5.71
50c	Fractured Aggregate Surface Treatment (F.A.S.T.) - 50000+ SY	SY	\$5.56

J. Banicki Construction
City of Sedona Street Maintenance Projects - JOC Unit Prices



Item No.	Description	Unit	Unit Price
1	RESET MANHOLE FRAME AND LID	EA	\$ 950.00
2	RESET SEWER CLEANOUT	EA	\$ 825.00
3	RESET WATER VALVE FRAME AND LID	EA	\$ 825.00
4	AGGREGATE BASE COURSE (0-100 TON)	TON	\$ 75.00
4A	AGGREGATE BASE COURSE {100+ TON}	TON	\$ 58.00
5	AGGREGATE BASE COURSE (RECONDITION) {0-300 SY}	S.Y.	\$ 21.00
SA	AGGREGATE BASE COURSE (RECONDITION) {300+ SY}	S.Y.	\$ 8.05
6	SUBGRADE PREP (0-300 SY)	S.Y.	\$ 17.25
6A	SUBGRADE PREP {300+ SY}	S.Y.	\$ 7.75
7	RECONDITION SHOULDER {0-300 SY}	S.Y.	\$ 17.00
7A	RECONDITION SHOULDER {300+ SY}	S.Y.	\$ 7.75
8	PMM SEAL COAT {0-1,000 SY}	S.Y.	\$ 10.00
8A	PMM SEAL COAT {1,000-10,000 SY}	S.Y.	\$ 7.00
88	PMM SEAL COAT {10,000-50,000 SY}	S.Y.	\$ 6.00
8C	PMM SEAL COAT {50,000+ SY}	S.Y.	\$ 5.50
9	CRACK SEAL ROADWAY {0-0.5" wide crack, minimum 5000 LF}	L.F.	\$ 12.50
9A	CRACK SEAL ROADWAY {0.5-1" wide crack, minimum 5000 LF}	L.F.	\$ 15.00
10	ASPHALTIC CONCRETE PAVEMENT MILLING (0 IN. TO 3 IN.) {0-4000 SY}	S.Y.	\$ 7.50
10A	ASPHALTIC CONCRETE PAVEMENT MILLING {0 IN. TO 3 IN.} {4000+ SY}	S.Y.	\$ 6.00
11	ASPHALTIC CONCRETE PAVEMENT {0 IN. TO 3 IN.} {0-100 TON}	TON	\$ 226.00
11A	ASPHALTIC CONCRETE PAVEMENT (0 IN. TO 3 IN.) {100+ TON}	TON	\$ 164.00
12	ASPHALTIC CONCRETE PAVEMENT { > 3 IN.} {0-100 TON}	TON	\$ 215.00
12A	ASPHALTIC CONCRETE PAVEMENT { > 3 IN.} {100+ TON}	TON	\$ 163.00
13	ASPHALTIC CONCRETE {PERMANENT PATCH}	TON	\$ 1,450.00
14	ASPHALTIC CONCRETE TERMINATION MAG DETAIL 201 TYPE "A" {0-100 LF}	L.F.	\$ 7.50
14A	ASPHALTIC CONCRETE TERMINATION MAG DETAIL 201 TYPE "A" {100+ LF}	L.F.	\$ 2.55
15	ASPHALTIC CONCRETE TERMINATION MAG DETAIL 201 TYPE "8" {0-100 LF}	L.F.	\$ 7.50
15A	ASPHALTIC CONCRETE TERMINATION MAG DETAIL 201 TYPE "B" {100+ LF}	L.F.	\$ 2.55
16	ASPHALTIC CONCRETE DRIVEWAY MAG DETAIL 205	TON	\$ 1,100.00
17	ASPHALTIC CONCRETE EDGE REPAIR (0-100 TON)	TON	\$ 412.50
17A	ASPHALTIC CONCRETE EDGE REPAIR {100+ TON}	TON	\$ 255.00
18	ASPHALTIC CONCRETE REMOVAL {2-4"} {0-100 SY}	S.Y.	\$ 19.00
18A	ASPHALTIC CONCRETE REMOVAL {2-4"} {100+ SY}	S.Y.	\$ 17.25
188	ASPHALTIC CONCRETE REMOVAL (5-6") {0-100 SY}	S.Y.	\$ 19.00
18C	ASPHALTIC CONCRETE REMOVAL {5-6"} {100+ SY}	S.Y.	\$ 18.60
19	SAW CUT ASPHALTIC CONCRETE PAVEMENT {2-4" depth} {0-100 LF}	L.F.	\$ 7.00
19A	SAW CUT ASPHALTIC CONCRETE PAVEMENT {2-4" depth} {100+ LF}	L.F.	\$ 4.60
198	SAW CUT ASPHALTIC CONCRETE PAVEMENT (5-6" depth) (0-100 LF)	L.F.	\$ 9.10
19C	SAW CUT ASPHALTIC CONCRETE PAVEMENT (5-6" depth) {100+ LF}	L.F.	\$ 6.25
20	4" PAVEMENT MARKINGS {0-100 LF}	L.F.	\$ 18.00
20A	4" PAVEMENT MARKINGS (100+ LF)	L.F.	\$ 2.75

21	12" TURN LANE MARKINGS (0-100 LF)	L.F.	\$ 16.20
21A	12" TURN LANE MARKINGS (100+ LF)	L.F.	\$ 3.00
22	12" CROSSWALK MARKINGS (0-100 LF)	L.F.	\$ 19.10
22A	12" CROSSWALK MARKINGS (100+ LF)	L.F.	\$ 6.60
23	CONCRETE HANDICAP RAMP (0-3 EA)	EA	\$ 8,720.00
23A	CONCRETE HANDICAP RAMP (4+ EA)	EA	\$ 8,500.00
24	CONCRETE SIDEWALK (4 IN.) NEW (0-20 SY)	S.Y.	\$ 200.00
24A	CONCRETE SIDEWALK (4 IN.) NEW (20-200 SY)	S.Y.	\$ 185.00
24B	CONCRETE SIDEWALK (4 IN.) NEW (200+ SY)	S.Y.	\$ 145.00
25	CONCRETE SIDEWALK (6 IN.) (NEW W/ FIBER REINFORCEMENT) (0-20 SY)	S.Y.	\$ 230.00
25A	CONCRETE SIDEWALK (6 IN.) (NEW W/ FIBER REINFORCEMENT) (20-200 SY)	S.Y.	\$ 195.00
258	CONCRETE SIDEWALK (6 IN.) (NEW W/ FIBER REINFORCEMENT) (200+ SY)	S.Y.	\$ 172.00
26	CONCRETE DRIVEWAY (6 IN.) (NEW W/ FIBER REINFORCEMENT) (0-20 SY)	S.Y.	\$ 240.00
26A	CONCRETE DRIVEWAY (6 IN.) (NEW W/ FIBER REINFORCEMENT) (20+ SY)	S.Y.	\$ 210.00
27	CONCRETE CURB & GUTTER (MAG TYPE" A", 6 IN.) (REPLACE) (0-20 LF)	L.F.	\$ 100.00
27A	CONCRETE CURB & GUTTER (MAG TYPE" A", 6 IN.) (REPLACE) (20-200 LF)	L.F.	\$ 68.50
27B	CONCRETE CURB & GUTTER (MAG TYPE" A", 6 IN.) (REPLACE) (200+ LF)	L.F.	\$ 56.75
28	CONCRETE CURB (MAG TYPE "8", (REPLACE) (0-20 LF)	L.F.	\$ 91.00
28A	CONCRETE CURB (MAG TYPE "B") (REPLACE) (20-200 LF)	L.F.	\$ 68.00
288	CONCRETE CURB (MAG TYPE "B") (REPLACE) (200+ LF)	L.F.	\$ 56.00
29	CONCRETE CURB & GUTTER (MAG TYPE "C") (REPLACE) (0-20 LF)	L.F.	\$ 107.00
29A	CONCRETE CURB & GUTTER (MAG TYPE "C") (REPLACE) (20-200 LF)	L.F.	\$ 68.00
29B	CONCRETE CURB & GUTTER (MAG TYPE "C") (REPLACE) (200+ LF)	L.F.	\$ 56.00
30	CONCRETE SIDEWALK (4 IN.) (REPLACE) (0-20 SY)	S.Y.	\$ 270.00
30A	CONCRETE SIDEWALK (4 IN.) (REPLACE) (20-200 SY)	S.Y.	\$ 245.00
30B	CONCRETE SIDEWALK (4 IN.) (REPLACE) (200+ SY)	S.Y.	\$ 230.00
31	CONCRETE CURB & GUTTER (MAG TYPE" A", 6 IN.) (NEW) (0-20 LF)	L.F.	\$ 85.00
31A	CONCRETE CURB & GUTTER (MAG TYPE" A", 6 IN.) (NEW) (20-200 LF)	L.F.	\$ 59.00
318	CONCRETE CURB & GUTTER (MAG TYPE" A", 6 IN.) (NEW) (200+ LF)	L.F.	\$ 49.00
32	CONCRETE CURB (MAG TYPE "8", (NEW) (0-20 LF)	L.F.	\$ 85.00
32A	CONCRETE CURB (MAG TYPE "8", (NEW) (20-200 LF)	L.F.	\$ 59.00
32B	CONCRETE CURB (MAG TYPE "B") (NEW) (200+ LF)	L.F.	\$ 49.00
33	CONCRETE CURB & GUTTER (MAG TYPE "C") (NEW) (0-20 LF)	L.F.	\$ 85.00
33A	CONCRETE CURB & GUTTER (MAG TYPE "C") (NEW) (20-200 LF)	L.F.	\$ 59.00
338	CONCRETE CURB & GUTTER (MAG TYPE "C") (NEW) (200+ LF)	L.F.	\$ 49.00
34	SEDONA RED CONCRETE COLOR	C.Y.	\$ 95.00
35	TREE REMOVAL 12 IN. TO 24 IN. Dia	EA	\$ 1,750.00
36	STREET SWEEPING (Power broom)	HR	\$ 165.00
37	SIDEWALK SWEEPING (Manual)	CR. HR	\$ 55.00
38	SIDEWALK SWEEPING (Power broom)	CR.HR	\$ 165.00
39	ONE (1) SACK ABC SLURRY (0-10 CY)	C.Y.	\$ 285.00
39A	ONE (1) SACK ABC SLURRY (10+ CY)	C.Y.	\$ 195.00
40	CORE SAMPLING	EA	\$ 140.00



41	STORM WATER POLLUTION PREVENTION (percentage of overall work order)	%	2%
42	MOBILIZATION (percentage of overall work order)	%	10%
43	QUALITY CONTROL & TESTING (percentage of overall work order)	%	2.5%
44	CONSTRUCTION STAKING	HR	\$ 230.00
45	UTILITY POTHOLING	HR	\$ 410.00
46	TACK COAT (0-300 SY)	S.Y.	\$ 11.75
46A	TACK COAT (300+ SY)	S.Y.	\$ 3.65
47	ASPHALTIC CONCRETE PULVERIZING (2-4") (0-1000 SY)	S.Y.	\$ 11.50
47A	ASPHALTIC CONCRETE PULVERIZING (2-4") (1000+ SY)	S.Y.	\$ 5.25
47B	ASPHALTIC CONCRETE PULVERIZING (S-6") (0-1000 SY)	S.Y.	\$ 12.55
47C	ASPHALTIC CONCRETE PULVERIZING (5-6") (1000+ SY)	S.Y.	\$ 5.50
48	DUAL LAYER WEED BARRIER	S.Y.	\$ 18.00
49	LIQUID ROAD SEAL COAT (0-1,000 SY)	S.Y.	\$ 9.25
49A	LIQUID ROAD SEAL COAT (1,000-10,000 SY)	S.Y.	\$ 8.00
49B	LIQUID ROAD SEAL COAT (10,000-50,000 SY)	S.Y.	\$ 7.50
49C	LIQUID ROAD SEAL COAT (50,000+ SY)	S.Y.	\$ 5.75
SO	FRACTURED AGGREGATE SURFACE TREATMENT (FAST) (0-1,000 SY)	S.Y.	\$ 300.00
SOA	FRACTURED AGGREGATE SURFACE TREATMENT (FAST) (1,000-10,000 SY)	S.Y.	\$ 54.00
SOB	FRACTURED AGGREGATE SURFACE TREATMENT (FAST) (10,000-50,000 SY)	S.Y.	\$ 11.00
SOC	FRACTURED AGGREGATE SURFACE TREATMENT (FAST) (50,000+ SY)	S.Y.	\$ 10.00



**CITY COUNCIL
AGENDA BILL**

**AB 2985
August 22, 2023
Regular Business**

Agenda Item: 8a

Proposed Action & Subject: Public hearing/presentation/discussion regarding the City of Sedona Development Impact Fee Audit Report for Fiscal Years 2020-21 and 2021-22.

Department Financial Services

Time to Present 10 minutes

Total Time for Item 20 minutes

Other Council Meetings N/A

Exhibits A. Development Impact Fee Audit Report Fiscal Years 2020-21 & 2021-22

City Attorney Approval	Reviewed 8/15/23 KWC	Expenditure Required
		\$ 0
City Manager's Recommendation	For presentation and discussion only.	Amount Budgeted
		\$ 0
		Account No. N/A (Description)
		Finance <input checked="" type="checkbox"/> Approval

SUMMARY STATEMENT

Background: Development Impact Fees (DIFs) are one-time charges applied to new development in order that new growth will pay its fair share of infrastructure improvements needed to provide municipal services, and to ensure that existing residents are not unduly burdened to pay for improvements and services needed to accommodate new development. The City of Sedona first adopted DIFs on May 18, 1998.

In 2011, the state legislature placed several requirements on development impact fees. To comply with the new statutory requirements, the City Council adopted updated Land Use Assumptions and Infrastructure Improvement Plan reports on March 4, 2014. On May 22, 2014, the City Council adopted the 2014 Development Impact Fee Report (the newly modified development impact fees) and amended City Code Chapter 14.05, Development Impact Fees, with the changes effective August 5, 2014. The 2014 Development Impact Fee Report was prepared by the consulting firm, TischlerBise, Inc. The 5-year update to the development impact fees was also prepared by TischlerBise, Inc. The 2018 Development Impact Fee Report was adopted by the City Council on June 25, 2019, and took effect on September 9, 2019.

A.R.S. §9-463.05(G) requires the City to either create an advisory committee **or** provide for a biennial certified audit of the land use assumptions, infrastructure improvement plans, and development impact fees. The statute further requires that the audit "...shall be conducted by one or more qualified professionals who are not employees or officials of the municipality and who did not prepare the infrastructure improvements plan." The term "qualified professional" is then statutorily defined as a professional engineer, surveyor, financial analyst, or planner providing services within the scope of the person's license, education or experience.

The audit for Fiscal Years 2020-21 and 2021-22 has been conducted by the certified public accounting firm, Heinfeld, Meech & Co. (H&M). The audit is required by statute to review the progress of the infrastructure improvements plan, including the collection and expenditures of development fees for each project in the plan, and evaluate any inequities in implementing the plan or imposing the development fee.

H&M's audit concluded that the City's DIF collections and expenditures are consistent with the 10-year plan identified in the 2014 and 2018 Development Impact Fee Reports and is consistent with A.R.S. §9-463.05, with the following exceptions:

- **Finding:** The expenditures reported for the Forest Road Connection project in the fiscal year 2022 Development Impact Fee Report did not agree to the City's final trial balance in the amount of \$180,823. After the DIF Report was finalized, the City made an adjustment to move expenditures from impact fee funded to bond funded. This movement of expenditures is not uncommon as the City's audited financial statements are prepared after the Impact Fee Annual Report.
 - **Corrective Action Taken:** None needed. Due to the timing of when the Impact Fee annual report must be issued in September and when the audited financials must be issued in December, a possibility of a variance between the two reports will always exist due to potential changes in year-end accruals and adjustments.
- **Finding:** For two of 40 permits reviewed, the City did not properly charge impact fees in accordance with the adopted infrastructure improvement plan resulting in undercharges of \$4,816.
 - **Corrective Action Taken:** As a result of a prior audit finding, City staff implemented an internal tracking and audit of each permit before it is released that requires each permit for a new single-family home be reviewed by a secondary Permit Technician other than the Permit Technician who issued the permit. The two permits referenced in the audit finding above were issued prior to receiving the results of the prior audit and the implementation of the corrective action. Previously, DIF fees, were often calculated and assessed immediately prior to the release of the permit. As part of the corrective action, DIF fees are assessed upon the submittal of the permit application and said fees are reviewed as part of the process to release the permit.

The statute requires a public hearing on the audit within 60 days of its release to the public. The H&M's audit report was posted on the City's website on August 1, 2023.

The required public hearing provides the opportunity for the public to comment regarding the DIF audit report.

Climate Action Plan/Sustainability Consistent: Yes - No - Not Applicable

Board/Commission Recommendation: Applicable - Not Applicable

Alternative(s): N/A

MOTION

I move to: For presentation/discussion only.



City of Sedona, Arizona
Report on Applying Agreed-Upon Procedures
Biennial Certification of Land Use Assumptions,
Infrastructure Improvement Plan
and Development Impact Fees
For the Period July 1, 2020 through June 30, 2022

**INDEPENDENT ACCOUNTANT’S REPORT ON
 APPLYING AGREED-UPON PROCEDURES**

Honorable Mayor and Members of the City Council

We have performed this agreed-upon procedures engagement to assist management of the City of Sedona, Arizona (City), with the requirement set forth in Arizona Revised Statutes (A.R.S.) 9-463.05.G.2 “to provide for a biennial certified audit of the municipality’s land use assumptions, infrastructure improvements plan and development fees”. As such, we have performed the procedures identified below, solely to assist users in evaluating the City’s compliance with the progress reporting requirements of the infrastructure improvement plan for the period from July 1, 2020 through June 30, 2022, as specified in A.R.S. 9-463.05.G.2. City of Sedona, Arizona’s management is responsible for its compliance with those requirements.

City of Sedona, Arizona’s management has agreed to and acknowledged that the procedures performed are appropriate to meet the intended purpose of assisting users in determining whether the City complied with the specified requirements. This report may not be suitable for any other purpose. The procedures performed may not address all the items of interest to a user of this report and may not meet the needs of all users of this report and, as such, users are responsible for determining whether the procedures performed are appropriate for their purposes.

We have applied the following procedures:

The progress of the infrastructure improvements plan.

- a. Compared growth projections for 2021 and 2022 related to population and dwelling units, as reported in the Land Use Assumptions to actual results. A list of variances are reported below.

2022				
	Projected¹	Actual²	Variance	Variance %
Total Population	10,820	9,834	(986)	-9%
Total Dwelling Units	6,756	6,814	58	1%

2021				
	Projected¹	Actual²	Variance	Variance %
Total Population	10,742	9,784	(958)	-9%
Total Dwelling Units	6,717	6,743	26	0%

1 The projected figures are sourced from the 2018 Land Use Assumptions Report page 6.

2 The source of actual population is the Arizona Office of Economic Opportunity Population

Estimates as of July 1, 2021 and 2022. The source of actual dwelling units is the City’s records.

- b. Obtained City-prepared Annual Reports for the Collection and Use of Development Impact Fees for the fiscal years ended June 30, 2021 and 2022 and performed the following procedures:
 - i. Agreed expenditures in the reports to the underlying accounting records.
 - ii. Determined project descriptions associated with each expenditure were identified in the Infrastructure Improvement Plan (IIP).

Finding #1

The expenditures reported for the Forest Road Connection project in the fiscal year 2022 Development Impact Fee Report did not agree to the City's final trial balance in the amount of \$180,823. After the Development Impact Fee Report was finalized, the City made an adjustment to move expenditures from impact fee funded to bond funded. This movement of expenditures is not uncommon as the City's audited financial statements are prepared after the Impact Fee Annual Report.

The collection and expenditures of development impact fees for each project in the plan.

- c. Selected a sample of 40 building permits issued and determined fees were charged in accordance with authorized fee schedules and that each permit holder was charged the same rate as another equivalent permit holder. Any inequities in the imposition of development fees are reported.

Finding #2

For two of 40 permits reviewed, the City did not properly charge impact fees in accordance with the adopted infrastructure improvement plan resulting in undercharges of \$4,816.

- d. Selected a sample of 25 expenditures and determined that the expenditures were associated with an approved project in the City's IIP.

No findings were noted as a result of applying this procedure.

Evaluating any inequities in implementing the plan or imposing the development impact fee.

- e. Determined each developer/unit was charged the same rate as another equivalent developer/unit by recalculating impact fees at the transaction level for the sample mentioned in step c. above.

No findings were noted as a result of applying this procedure.

- f. Determined that there were no instances in which the City waived development impact fees, except as allowed for under A.R.S. 9-499.10.B and A.R.S. 9-500.18.

No findings were noted as a result of applying this procedure.

We were engaged by City of Sedona, Arizona's management to perform this agreed-upon procedures engagement and conducted our engagement in accordance with attestation standards established by the American Institute of Certified Public Accountants. We were not engaged to and did not conduct an examination or review engagement, the objective of which would be the expression of an opinion or conclusion, respectively, on compliance with the specified requirements. Accordingly, we do not express such an opinion or conclusion. Had we performed additional procedures, other matters might have come to our attention that would have been reported to you.

We are required to be independent of City of Sedona, Arizona and to meet our other ethical responsibilities, in accordance with relevant ethical requirements related to our agreed-upon procedures engagement.

This report is intended solely for the information and use of the management of City of Sedona, Arizona, and is not intended to be and should not be used by anyone other than these specified parties.

Heinfeld Meech & Co. PC

Heinfeld, Meech & Co., P.C.
Scottsdale, Arizona
June 15, 2023



**CITY COUNCIL
AGENDA BILL**

**AB 2953
August 22, 2023
Regular Business**

Agenda Item: 8b
Proposed Action & Subject: Presentation/discussion regarding June 2023 Sales and Bed Tax Report.

Department	Financial Services
Time to Present	20 min
Total Time for Item	30 min
Other Council Meetings	N/A
Exhibits	A. June 2023 Sales and Bed Tax Report B. PowerPoint Presentation

City Attorney Approval	Reviewed 8/15/23 KWC	Expenditure Required
		\$ N/A
City Manager's Recommendation	For presentation and discussion only.	Amount Budgeted
		\$ N/A
		Account No. (Description)
		Finance Approval <input checked="" type="checkbox"/>

SUMMARY STATEMENT

Background: On March 14, 2023 Councilor Furman requested to agendize this presentation and discussion. Councilor Fultz seconded that request. Since the City was going through the annual budget process at the time, which provided an opportunity to discuss all revenues and expenditures and required a considerable time commitment for the Finance Director, it was agreed that the discussion of a deeper dive into bed and sales taxes would be agendized after the budget process was completed.

The final fiscal year 2024 budget has now been adopted and a presentation will be made based on the June 2023 Sales and Bed Tax Report. This item will provide an opportunity for the City Council to discuss the contents of the report.

Climate Action Plan/Sustainability Consistent: Yes - No - Not Applicable

Board/Commission Recommendation: Applicable - Not Applicable

Alternative(s): None

MOTION

I move to: Presentation/discussion only.

Sales Tax Revenues by Category

Month	Retail	Restaurant & Bar	Hotel/Motel	Construction	Leasing	Communications & Utilities	Amusements & Other	Totals
City Sales Tax Revenues by Category and by Month								
July 2021	838,054	\$ 433,735	\$ 548,655	\$ 217,070	\$ 144,246	\$ 66,645	\$ 122,765	\$ 2,371,170
August 2021	816,112	407,527	567,906	116,831	142,622	68,876	117,481	2,237,355
September 2021	905,499	513,583	737,029	139,929	184,095	69,151	131,091	2,680,377
October 2021	1,025,419	576,025	922,123	133,049	190,939	65,184	160,526	3,073,265
November 2021	917,977	499,249	812,224	126,890	170,352	56,451	135,092	2,718,235
December 2021	1,032,105	481,518	679,453	137,907	171,397	62,690	95,083	2,660,153
January 2022	799,129	388,620	554,271	200,460	161,413	66,789	72,631	2,243,313
February 2022	837,596	455,020	774,763	182,213	163,634	61,950	114,206	2,589,382
March 2022	1,039,427	613,199	861,929	163,309	191,733	61,955	190,819	3,122,371
April 2022	1,020,634	638,121	1,042,841	133,182	146,074	64,545	228,550	3,273,947
May 2022	992,513	594,144	999,727	176,456	181,003	54,141	148,004	3,145,988
June 2022	902,002	472,025	680,996	217,241	167,822	69,234	124,129	2,633,449
Total FY 2022	\$ 11,126,467	\$ 6,072,766	\$ 9,181,917	\$ 1,944,537	\$ 2,015,330	\$ 767,611	\$ 1,640,377	\$ 32,749,005
July 2022	\$ 759,167	\$ 406,269	\$ 517,128	\$ 139,987	\$ 155,542	\$ 48,705	\$ 122,342	\$ 2,149,140
August 2022	797,223	369,186	502,766	195,095	156,688	96,617	80,318	2,197,893
September 2022	874,790	486,767	650,976	131,089	173,564	69,253	105,658	2,492,097
October 2022	1,053,822	582,764	868,383	161,238	177,348	39,266	139,165	3,021,986
November 2022	914,839	492,347	744,020	138,314	152,930	83,081	106,366	2,631,897
December 2022	896,682	424,843	586,451	134,064	168,411	67,347	83,243	2,361,041
January 2023	764,648	378,813	644,950	124,431	149,910	70,888	72,280	2,205,920
February 2023	792,929	463,351	765,546	138,808	163,484	68,826	97,392	2,490,336
March 2023	990,262	595,699	984,599	200,709	175,427	75,155	169,033	3,190,884
April 2023	1,113,347	691,082	1,011,113	216,734	174,942	58,701	207,381	3,473,300
May 2023	966,539	592,166	803,577	130,357	172,080	61,165	128,187	2,854,071
June 2023	881,226	534,000	730,408	171,859	161,429	76,532	131,490	2,686,944
Total Year-to-Date FY 2023	\$ 10,805,474	\$ 6,017,287	\$ 8,809,917	\$ 1,882,685	\$ 1,981,755	\$ 815,536	\$ 1,442,855	\$ 31,755,509
Current Month Comparison to Same Month Last Year								
June 2022 vs. June 2023	\$ (20,776)	\$ 61,975	\$ 49,412	\$ (45,382)	\$ (6,393)	\$ 7,298	\$ 7,361	\$ 53,495
Change from June to June	-2%	13%	7%	-21%	-4%	11%	6%	2%
Year-to-Date Comparison to Year-to-Date Last Year								
Difference in YTD	\$ (320,993)	\$ (55,479)	\$ (372,000)	\$ (61,852)	\$ (33,575)	\$ 47,925	\$ (197,522)	\$ (993,496)
% Change from Prior YTD	-3%	-1%	-4%	-3%	-2%	6%	-12%	-3%

NOTE: For this table only, certain anticipated refunds have been adjusted in the prior months to enhance comparability.

Sales & Bed Tax Revenues by Month

City Sales Tax Revenues

Month	FY 2022 Actuals	FY 2023 Actuals	Actual Variance	FY 2023 Budget	Budget Variance
July	\$ 2,371,171	\$ 2,149,138	-9%	\$ 2,645,660	-19%
August	2,237,356	2,197,897	-2%	2,614,650	-16%
September	2,680,378	2,492,094	-7%	2,937,390	-15%
October	3,073,265	3,021,987	-2%	3,103,800	-3%
November	2,718,236	2,631,897	-3%	2,990,220	-12%
December	2,660,152	2,361,041	-11%	2,799,530	-16%
January	2,243,313	2,205,919	-2%	2,495,980	-12%
February	2,589,382	2,490,337	-4%	2,704,410	-8%
March	3,122,370	3,190,884	2%	3,653,750	-13%
April	3,273,947	3,473,299	6%	3,803,920	-9%
May	3,145,989	2,854,072	-9%	3,540,360	-19%
June	2,633,448	2,686,944	2%	3,280,330	-18%
Totals	\$ 32,749,006	\$ 31,755,509	-3%	\$ 36,570,000	-13%

Bed Tax Revenues

Month	FY 2022 Actuals	FY 2023 Actuals	Actual Variance	FY 2023 Budget	Budget Variance
July	\$ 534,113	\$ 499,299	-7%	\$ 610,160	-18%
August	555,700	498,556	-10%	656,110	-24%
September	721,023	633,082	-12%	771,040	-18%
October	898,777	844,792	-6%	973,790	-13%
November	793,202	724,025	-9%	842,810	-14%
December	666,066	571,961	-14%	690,250	-17%
January	543,480	633,341	17%	620,690	2%
February	760,338	748,220	-2%	763,200	-2%
March	837,639	959,154	15%	1,121,550	-14%
April	985,921	982,381	0%	1,232,760	-20%
May	1,002,126	779,126	-22%	1,080,120	-28%
June	644,379	714,052	11%	869,520	-18%
Totals	\$ 8,942,766	\$ 8,587,989	-4%	\$ 10,232,000	-16%

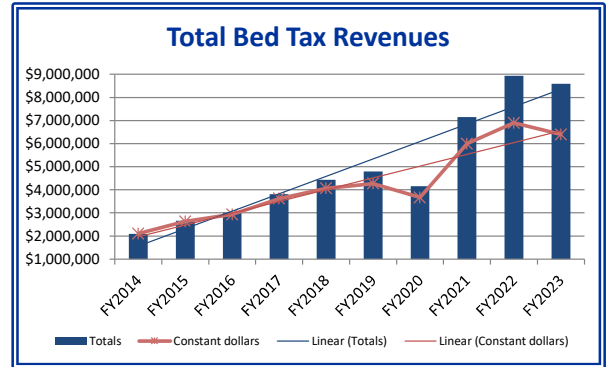
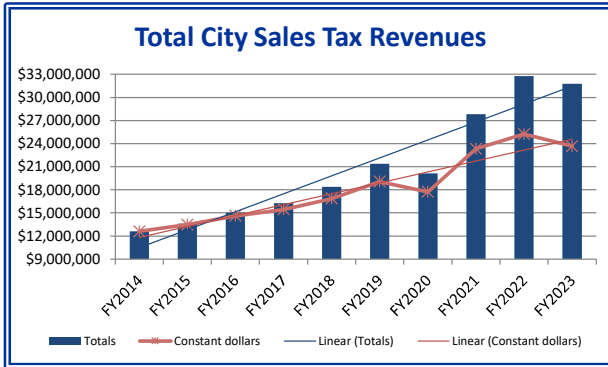
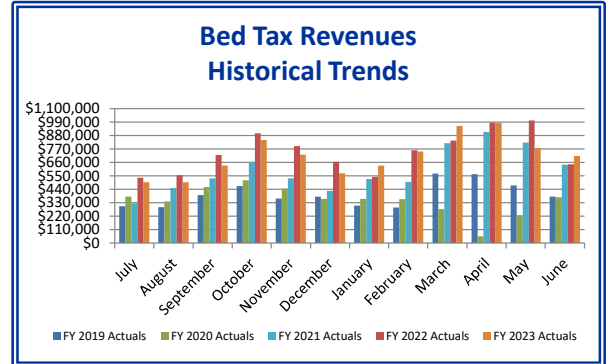
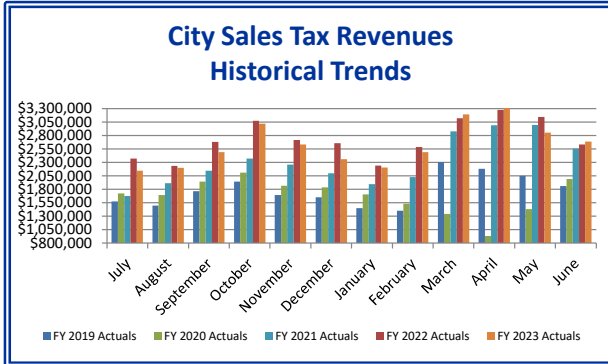
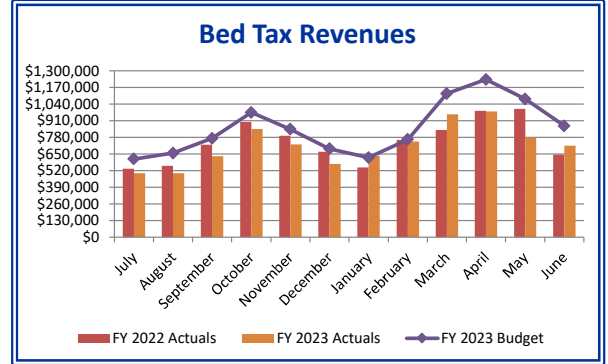
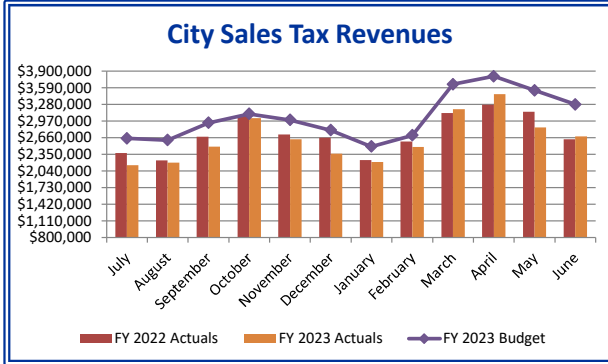

Historical Changes - City Sales Tax

- Early FY 2020:** Effective October 1, 2019, all retail marketplaces are required to collect and remit taxes. This is the result of Wayfair v. South Dakota; however, many of the marketplaces were already collecting and remitting taxes.
- Mid FY 2019:** Effective January 1, 2019, all online marketplaces (not just AirBnB) are required to remit short-term residential rental taxes on behalf of property owners. This impacts the Hotel/Motel category.
- Late FY 2018:** The tax rate increased from 3.0% to 3.5% effective March 1, 2018.
- Mid FY 2017:** Effective January 1, 2017, the City is no longer allowed to prohibit short-term residential rentals. This impacts the Hotel/Motel category.
- Mid FY 2016:** The state took over collections effective January 1, 2016. For several months, tax collections were higher as a result of more timely payments by taxpayers presumably because they did not have to file a separate form with the City.

Historical Changes - Bed Tax

- Mid FY 2019:** Effective January 1, 2019, all online marketplaces (not just AirBnB) are required to remit short-term residential rental taxes on behalf of property owners.
- Mid FY 2017:** Effective January 1, 2017, the City is no longer allowed to prohibit short-term residential rentals.
- Mid FY 2016:** The state took over collections effective January 1, 2016. For several months, tax collections were higher as a result of more timely payments by taxpayers presumably because they did not have to file a separate form with the City.
- Mid FY 2014:** The tax rate increased from 3.0% to 3.5% effective January 1, 2014.

Historical Sales Tax Revenues by Category

Retail Historical Trends

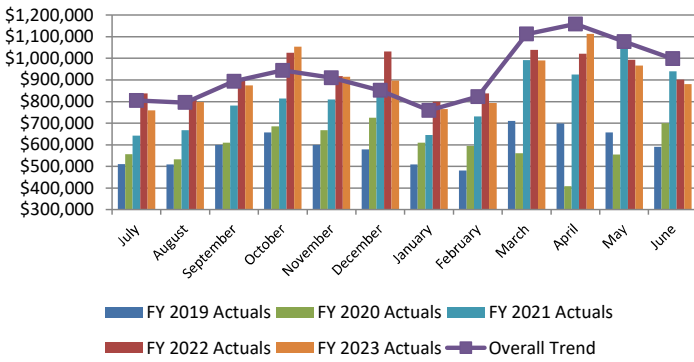

Restaurant & Bar Historical Trends

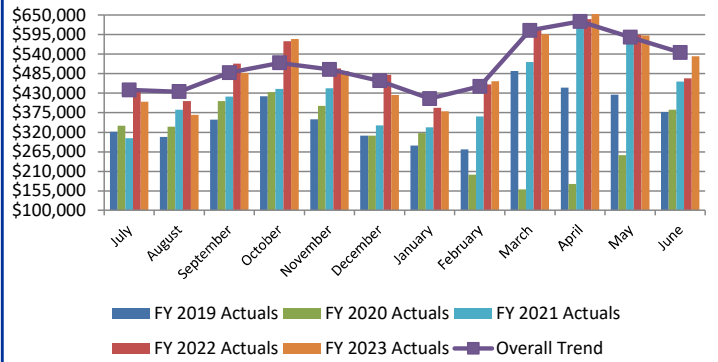

Hotel/Motel Historical Trends

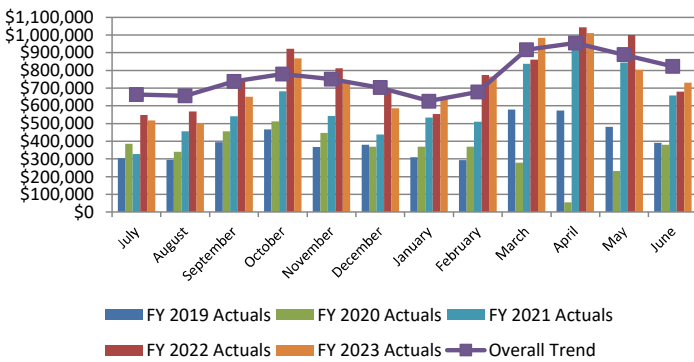

Construction Historical Trends

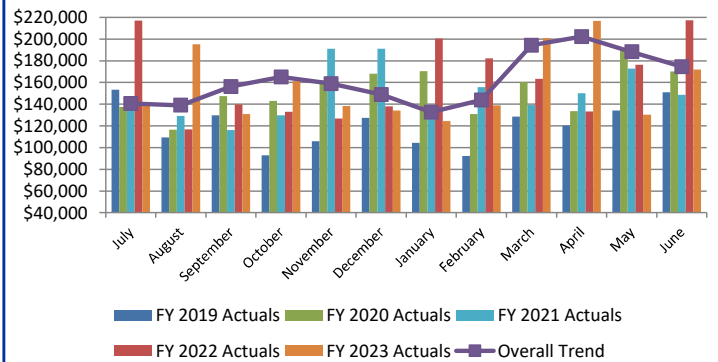

Leasing Historical Trends

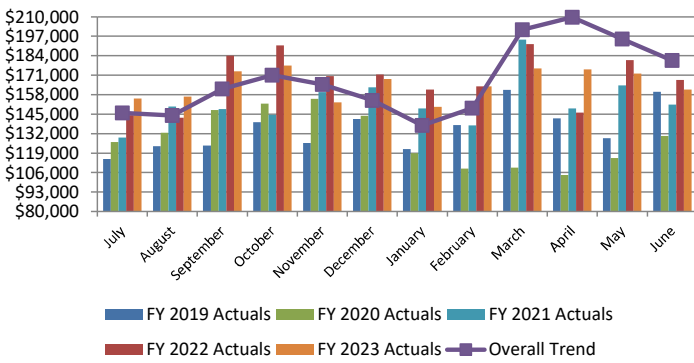

Communications & Utilities Historical Trends

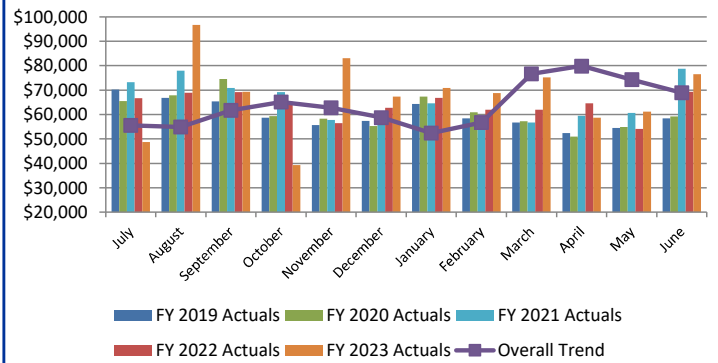

Amusements & Other Historical Trends

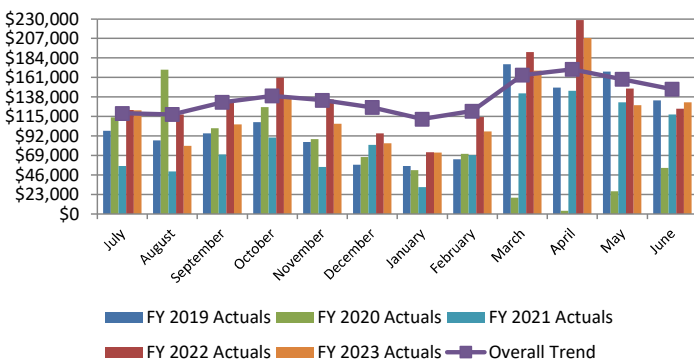

NOTE: The Overall Trend lines represent the trend in relation to total sales tax revenues to demonstrate how each category follows or does not follow the overall seasonal trends.

Historical Hotel Occupancy & Average Daily Room Rate

Monthly Hotel Occupancy & Average Daily Room Rate

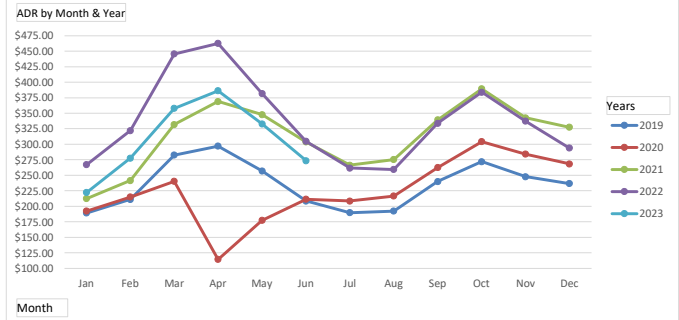
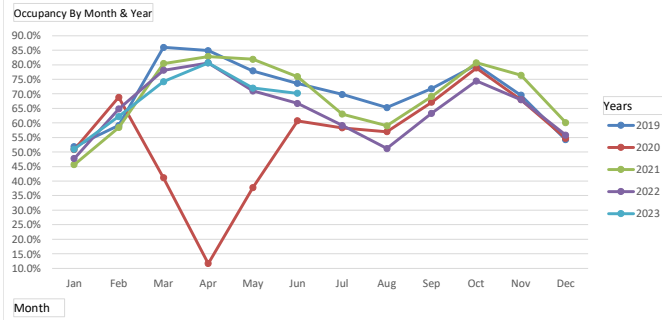

Average Annual Hotel Occupancy & Average Annual Room Rate as of June

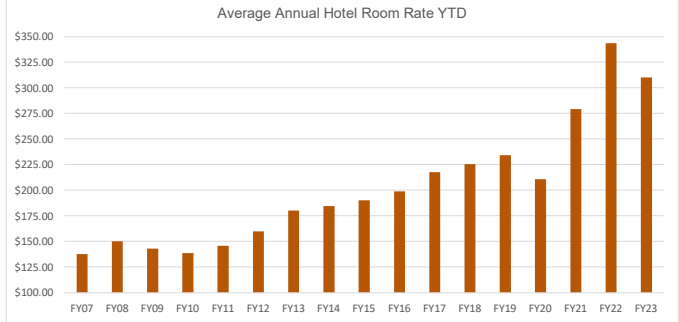
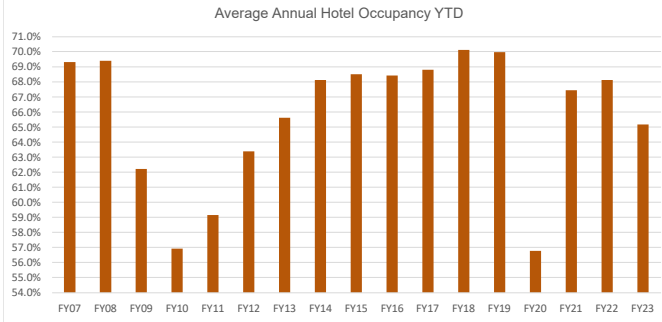

Historical Hotel Occupancy

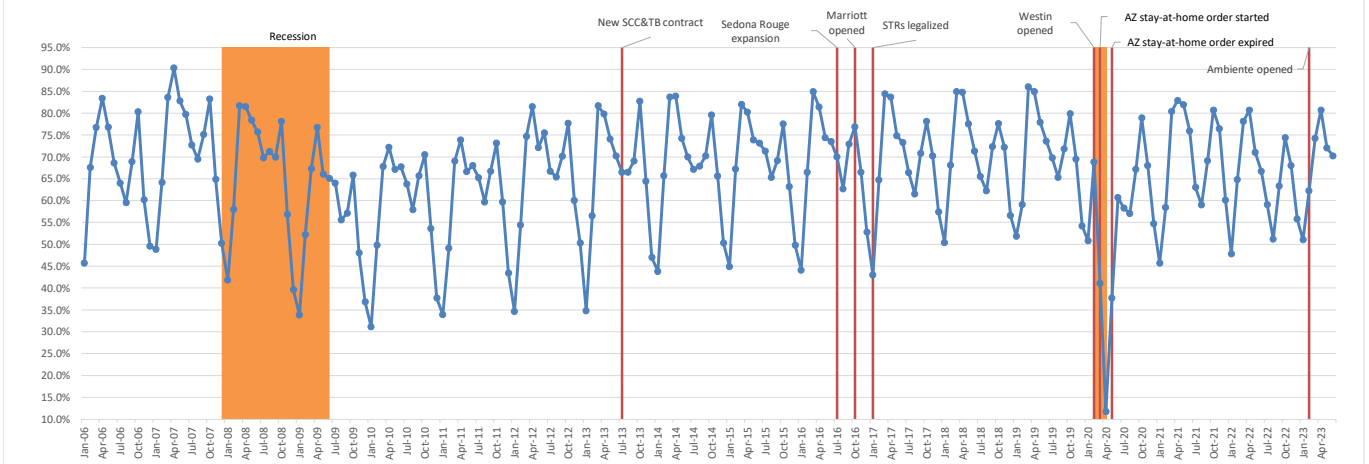

Historical Average Daily Room Rate

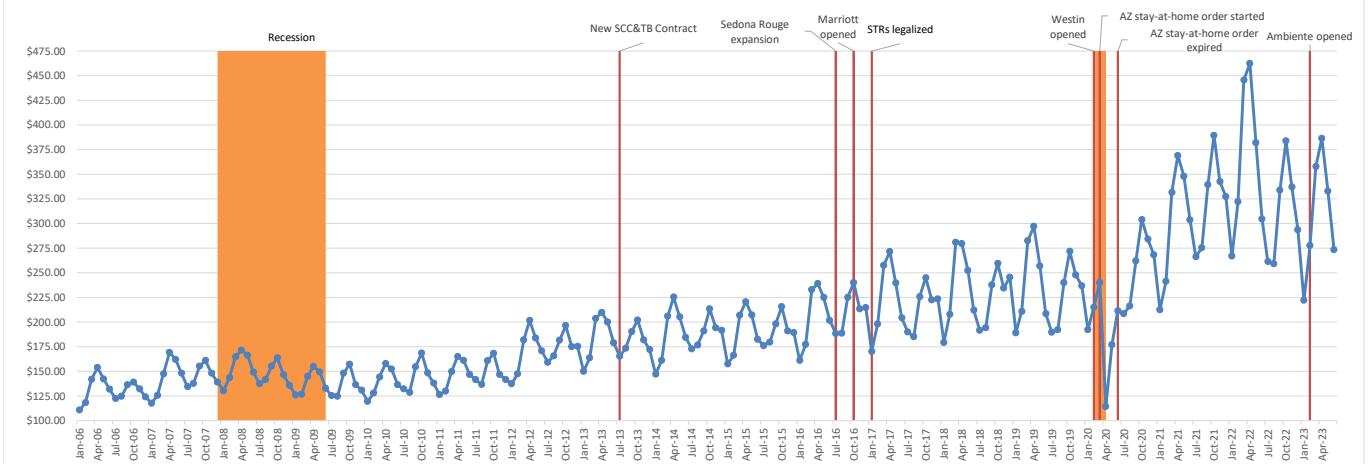

City Tax Code Definitions Related to Hotel/Motel Category

Section 8-100. General Definitions.

"Hotel" means any public or private hotel, inn, hostelry, tourist home, house, motel, rooming house, apartment house, trailer, or other lodging place within the City offering lodging, wherein the owner thereof, for compensation, furnishes lodging to any transient, except foster homes, rest homes, sheltered care homes, nursing homes, or primary health care facilities.

"Lodging (Lodging Space)" means any room or apartment in a hotel or any other provider of rooms, trailer spaces, or other residential dwelling spaces; or the furnishings or services and accommodations accompanying the use and possession of said dwelling space, including storage or parking space for the property of said tenant.

NOTE: The above occupancy and average daily room rate data is for traditional hotel type entities only.



Preliminary June 2023 Sales & Bed Tax Revenues

City Council Meeting
August 22, 2023



Preliminary Numbers

FY 2023 year-end adjustments to be made

FY 2022 year-end adjustments were approx. \$65k

Not expected to significantly alter this analysis



Confidentiality Rules

Cannot disclose any information regarding individual taxpayers

- Not even whether or not they pay taxes

Cannot disclose any information about a segment of taxpayers where 10 or fewer represent a significant portion of the category

Only City employees with a need to know for tax collection purposes are allowed access

- Even CM is specifically identified as not having a need to know unless such a small city that the CM also serves as CFO



Comparison to Prior Year and Budget

City Sales Tax Revenues

Month	FY 2022 Actuals	FY 2023 Actuals	Actual Variance	FY 2023 Budget	Budget Variance
July	\$ 2,371,171	\$ 2,149,138	-9%	\$ 2,645,660	-19%
August	2,237,356	2,197,897	-2%	2,614,650	-16%
September	2,680,378	2,492,094	-7%	2,937,390	-15%
October	3,073,265	3,021,987	-2%	3,103,800	-3%
November	2,718,236	2,631,897	-3%	2,990,220	-12%
December	2,660,152	2,361,041	-11%	2,799,530	-16%
January	2,243,313	2,205,919	-2%	2,495,980	-12%
February	2,589,382	2,490,337	-4%	2,704,410	-8%
March	3,122,370	3,190,884	2%	3,653,750	-13%
April	3,273,947	3,473,299	6%	3,803,920	-9%
May	3,145,989	2,854,072	-9%	3,540,360	-19%
June	2,633,448	2,686,944	2%	3,280,330	-18%
Totals	\$ 32,749,006	\$ 31,755,509	-3%	\$ 36,570,000	-13%

Bed Tax Revenues

Month	FY 2022 Actuals	FY 2023 Actuals	Actual Variance	FY 2023 Budget	Budget Variance
July	\$ 534,113	\$ 499,299	-7%	\$ 610,160	-18%
August	555,700	498,556	-10%	656,110	-24%
September	721,023	633,082	-12%	771,040	-18%
October	898,777	844,792	-6%	973,790	-13%
November	793,202	724,025	-9%	842,810	-14%
December	666,066	571,961	-14%	690,250	-17%
January	543,480	633,341	17%	620,690	2%
February	760,338	748,220	-2%	763,200	-2%
March	837,639	959,154	15%	1,121,550	-14%
April	985,921	982,381	0%	1,232,760	-20%
May	1,002,126	779,126	-22%	1,080,120	-28%
June	644,379	714,052	11%	869,520	-18%
Totals	\$ 8,942,766	\$ 8,587,989	-4%	\$ 10,232,000	-16%

Possible impacts:

- Reopening of Europe
- Significant inflation
- Talk of a possible coming recession
- Hold on destination marketing



Comparison to Pre-COVID

	June 2019	June 2023	% Change	FY 2019	FY 2023	% Change
Sales Tax	\$1,862,115	\$2,686,944	44%	\$21,381,693	\$31,755,509	49%
Bed Tax	\$380,099	\$714,052	88%	\$4,788,239	\$8,587,989	79%

NOTE: Western Region CPI increase from June 2019 to June 2023 was 20%.



Compared to Constant Dollars

Total City Sales Tax Revenues

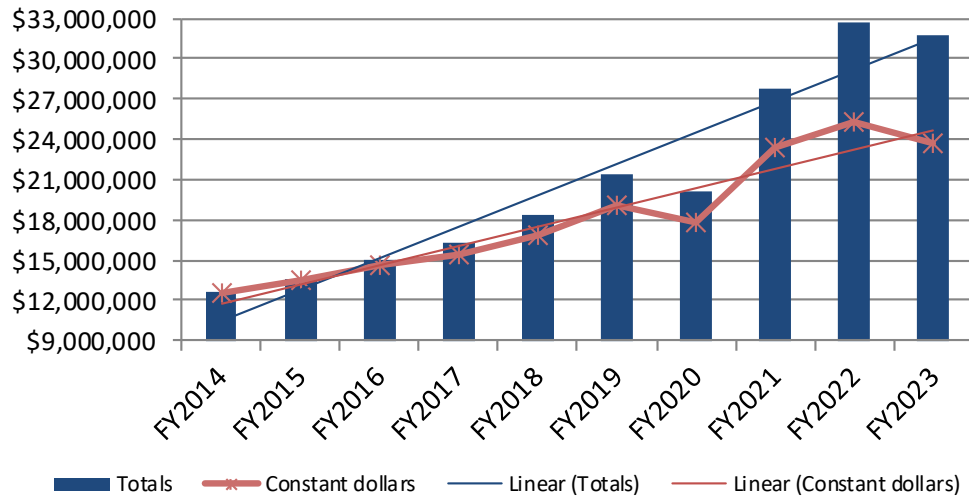

Total Bed Tax Revenues

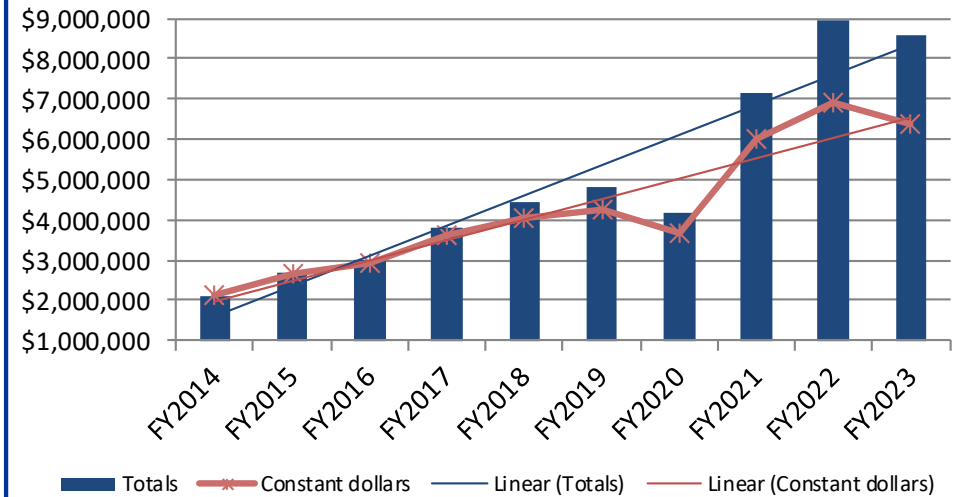

	FY2015	FY2016	FY2017	FY2018	FY2019	FY2020	FY2021	FY2022	FY2023
Sales actual change	8%	10%	8%	13%	16%	-6%	38%	18%	-3%
Sales constant \$ change	7%	8%	6%	9%	13%	-7%	31%	8%	-6%
Bed actual change	27%	13%	27%	16%	8%	-13%	72%	25%	-4%
Sales constant \$ change	25%	11%	24%	12%	5%	-14%	63%	15%	-7%



Traditional Hotel Occupancy & ADR

Monthly Hotel Occupancy & Average Daily Room Rate

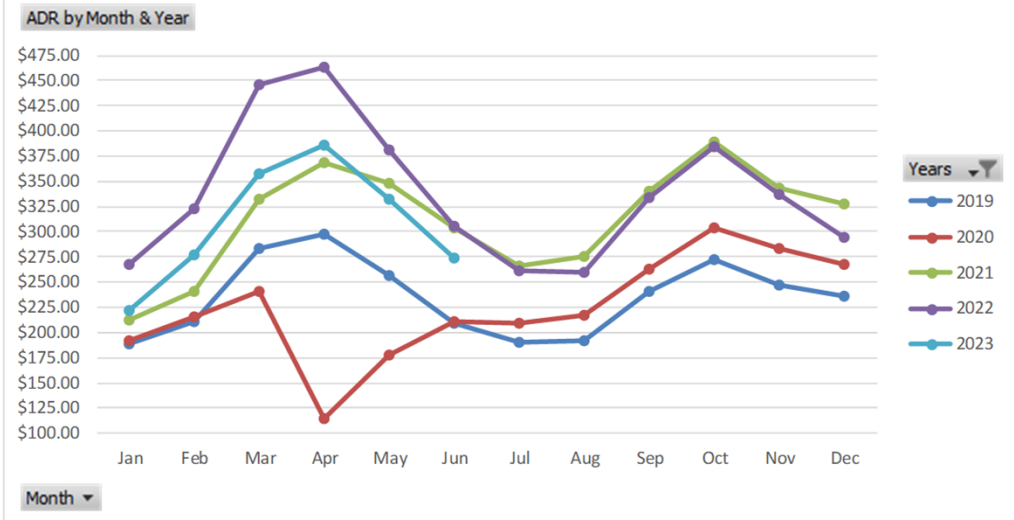
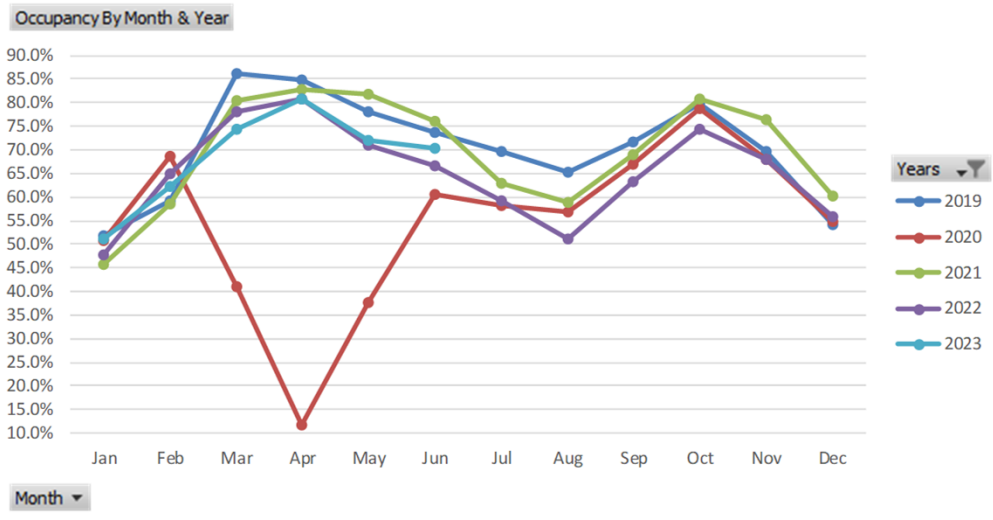

SCTC Section 8-100. General Definitions.

"Hotel" means any public or private hotel, inn, hostelry, tourist home, house, motel, rooming house, apartment house, trailer, or other lodging place within the City offering lodging, wherein the owner thereof, for compensation, furnishes lodging to any transient, except foster homes, rest homes, sheltered care homes, nursing homes, or primary health care facilities.

"Lodging (Lodging Space)" means any room or apartment in a hotel or any other provider of rooms, trailer spaces, or other residential dwelling spaces; or the furnishings or services and accommodations accompanying the use and possession of said dwelling space, including storage or parking space for the property of said tenant.



Average Annual Traditional Hotel Occupancy & ADR

Average Annual Hotel Occupancy YTD

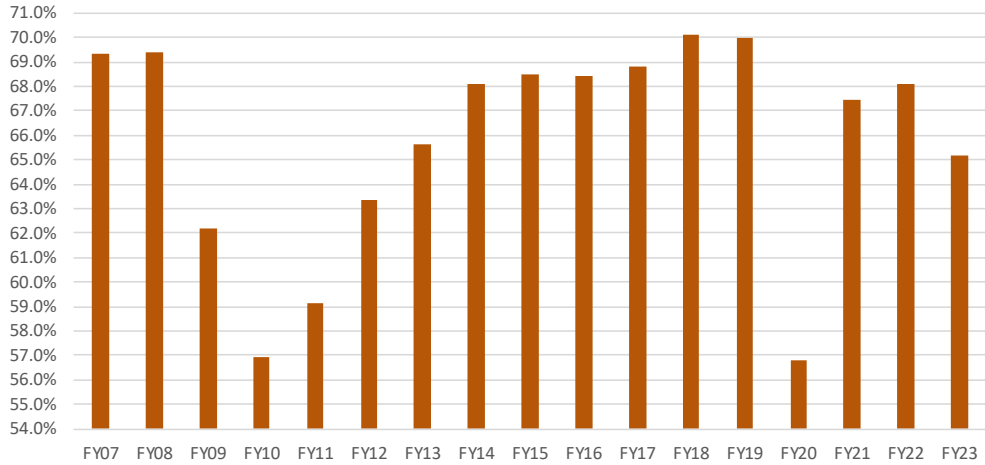

Average Annual Hotel Room Rate YTD

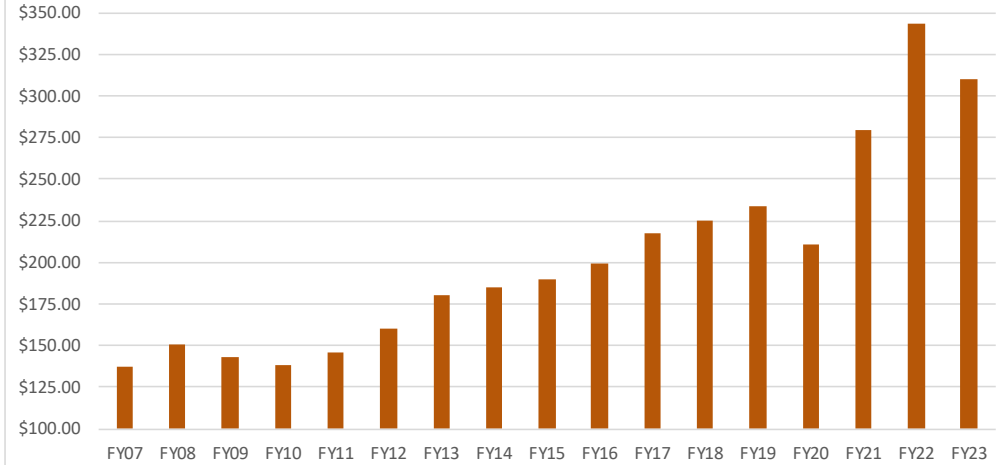

June 2023 Revenues by Period End Date

Period End Date	Amount
2003	1.00
2007	(19.56)
2008	0.03
2009	(0.13)
2010	57.98
2012	(339.60)
2017	482.51
2018	(0.96)
2019	785.28
2020	129.57
2021	5,487.54
2022	3,942.07
2023:	
Jan	(484.69)
Feb	1,276.24
Mar	2,353.12
Apr	14,030.31
May	101,223.95
Jun	3,265,455.65
Jul	6,374.71
Aug	6.29
Sep	128.81
Dec	106.01
Grand Total	\$3,400,996.13

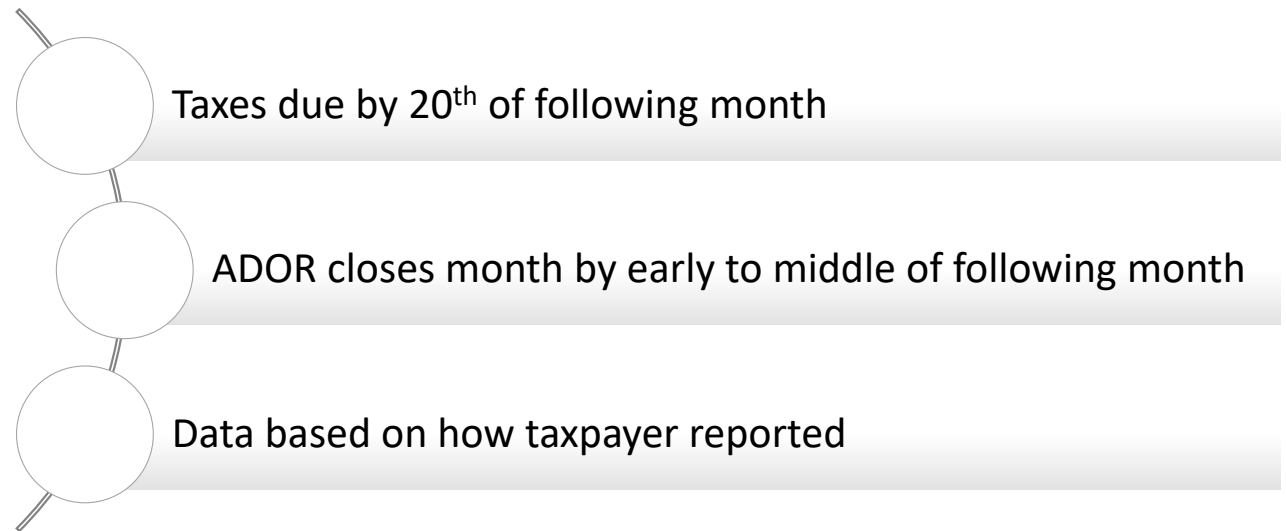

Reported Categories⁽¹⁾

Retail

- Retail sales, excluding food for home consumption (groceries)⁽²⁾
- Medical and adult use marijuana
- Online marketplace
- Use tax

Restaurant & Bar

Hotel/Motel

Construction

- Prime contracting
- Speculative builders
- Owner/builder contracting
- Maintenance, repair, replacement and alteration (MRRA) construction activities

Leasing⁽³⁾

- Commercial rental/leasing of real property
- Rental/leasing of tangible personal property

Communications & Utilities

- Utilities
- Communications

Amusements & Other

- Amusements
- Transporting
- Publication
- Job printing
- Collections of tax due prior to 2015 not applicable in current categories
- License fees

⁽¹⁾See the [Sedona City Tax Code](#) for detailed explanations of each category. Sedona does charge tax on food.

⁽²⁾Sedona does charge tax on food.

⁽³⁾Sedona does not charge tax on long-term residential rentals (30 or more days).



Month	Retail	Restaurant & Bar	Hotel/Motel	Construction ⁽¹⁾	Leasing	Communi-cations & Utilities	Amusements & Other	Totals
City Sales Tax Revenues by Category and by Month								
July 2021	838,054	\$ 433,735	\$ 548,655	\$ 217,070	\$ 144,246	\$ 66,645	\$ 122,765	\$ 2,371,170
August 2021	816,112	407,527	567,906	116,831	142,622	68,876	117,481	2,237,355
September 2021	905,499	513,583	737,029	139,929	184,095	69,151	131,091	2,680,377
October 2021	1,025,419	576,025	922,123	133,049	190,939	65,184	160,526	3,073,265
November 2021	917,977	499,249	812,224	126,890	170,352	56,451	135,092	2,718,235
December 2021	1,032,105	481,518	679,453	137,907	171,397	62,690	95,083	2,660,153
January 2022	799,129	388,620	554,271	200,460	161,413	66,789	72,631	2,243,313
February 2022	837,596	455,020	774,763	182,213	163,634	61,950	114,206	2,589,382
March 2022	1,039,427	613,199	861,929	163,309	191,733	61,955	190,819	3,122,371
April 2022	1,020,634	638,121	1,042,841	133,182	146,074	64,545	228,550	3,273,947
May 2022	992,513	594,144	999,727	176,456	181,003	54,141	148,004	3,145,988
June 2022	902,002	472,025	680,996	217,241	167,822	69,234	124,129	2,633,449
Total FY 2022	\$ 11,126,467	\$ 6,072,766	\$ 9,181,917	\$ 1,944,537	\$ 2,015,330	\$ 767,611	\$ 1,640,377	\$ 32,749,005
July 2022	\$ 759,167	\$ 406,269	\$ 517,128	\$ 139,987	\$ 155,542	\$ 48,705	\$ 122,342	\$ 2,149,140
August 2022	797,223	369,186	502,766	195,095	156,688	96,617	80,318	2,197,893
September 2022	874,790	486,767	650,976	131,089	173,564	69,253	105,658	2,492,097
October 2022	1,053,822	582,764	868,383	161,238	177,348	39,266	139,165	3,021,986
November 2022	914,839	492,347	744,020	138,314	152,930	83,081	106,366	2,631,897
December 2022	896,682	424,843	586,451	134,064	168,411	67,347	83,243	2,361,041
January 2023	764,648	378,813	644,950	124,431	149,910	70,888	72,280	2,205,920
February 2023	792,929	463,351	765,546	138,808	163,484	68,826	97,392	2,490,336
March 2023	990,262	595,699	984,599	200,709	175,427	75,155	169,033	3,190,884
April 2023	1,113,347	691,082	1,011,113	216,734	174,942	58,701	207,381	3,473,300
May 2023	966,539	592,166	803,577	130,357	172,080	61,165	128,187	2,854,071
June 2023	881,226	534,000	730,408	171,859	161,429	76,532	131,490	2,686,944
Total Year-to-Date FY 2023	\$ 10,805,474	\$ 6,017,287	\$ 8,809,917	\$ 1,882,685	\$ 1,981,755	\$ 815,536	\$ 1,442,855	\$ 31,755,509
Current Month Comparison to Same Month Last Year								
June 2022 vs. June 2023	\$ (20,776)	\$ 61,975	\$ 49,412	\$ (45,382)	\$ (6,393)	\$ 7,298	\$ 7,361	\$ 53,495
Change from June to June	-2%	13%	7%	-21%	-4%	11%	6%	2%
Year-to-Date Comparison to Year-to-Date Last Year								
Difference in YTD	\$ (320,993)	\$ (55,479)	\$ (372,000)	\$ (61,852)	\$ (33,575)	\$ 47,925	\$ (197,522)	\$ (993,496)
% Change from Prior YTD	-3%	-1%	-4%	-3%	-2%	6%	-12%	-3%

⁽¹⁾In June 2022, Construction included significant delinquencies. Excluding delinquent collections, it is estimated that June 2023 would have been 13% less than June 2022.



Comparison to Pre-COVID by Category

	June 2019	June 2023	% Change	FY 2019	FY 2023	% Change
Retail	\$590,382	\$881,226	49%	\$7,104,613	\$10,805,474	52%
Restaurant & Bar	\$377,501	\$534,000	41%	\$4,366,956	\$6,017,287	38%
Hotel/Motel	\$390,862	\$730,408	87%	\$4,839,928	\$8,809,917	82%
Construction	\$151,109	\$171,859	14%	\$1,449,767	\$1,882,685	30%
Leasing	\$159,996	\$161,429	1%	\$1,621,589	\$1,981,755	22%
Communications & Utilities	\$58,414	\$76,532	31%	\$718,813	\$815,536	13%
Amusements & Other	\$133,851	\$131,490	-2%	\$1,280,028	\$1,442,855	13%



Increase in Estimated Taxable Sales

	FY 2019	FY 2023	Increase
Retail	\$202,988,943	\$308,727,829	\$105,738,886
Restaurant & Bar	\$124,770,171	\$171,922,486	\$47,152,314
Hotel/Motel	\$138,283,657	\$251,711,914	\$113,428,257
Construction	\$41,421,914	\$53,791,000	\$12,369,086
Leasing	\$46,331,114	\$56,621,571	\$10,290,457
Communications & Utilities	\$20,537,514	\$23,301,029	\$2,763,514
Amusements & Other	\$36,572,229	\$41,224,429	\$4,652,200



Increase/(Decrease) in Revenues

	Over (Under) Prior Year	Over (Under) Budget ⁽¹⁾
Sales Tax	\$ (993,497)	\$(4,814,491)
Bed Tax	(354,777)	(1,644,011)
Total	\$(1,348,274)	\$(6,458,502)

⁽¹⁾During FY 2024 budget process, the total FY 2023 sales and bed tax revenue was estimated as \$7.2M under budget and still generating a General Fund surplus of \$11.5M. Final year-end adjustments for both revenues and expenditures will impact the calculation of the actual surplus, but the final amount should still be close to the estimate or potentially higher.



Questions?





**CITY COUNCIL
AGENDA BILL**

**AB 2950
August 22, 2023
Regular Business**

Agenda Item: 8c
Proposed Action & Subject: Discussion/direction regarding an Ordinance amending the Sedona City Code Title 10 (Vehicles and Traffic) by adding Chapter 10.30 (Improper Motor Vehicle Equipment) and a voluntary agreement with local OHV rental companies.

Department	City Attorney
Time to Present	15 Minutes
Total Time for Item	90 Minutes
Other Council Meetings	May 23, 2023; April 11, 2023
Exhibits	A. Ordinance B. OHV Accident Reports C. ROHVA Letter to City

City Attorney Approval	Reviewed 8/15/23 KWC	Expenditure Required	\$ N/A
City Manager's Recommendation	For discussion and direction only.	Amount Budgeted	\$ N/A
		Account No. (Description)	N/A
		Finance Approval	<input checked="" type="checkbox"/>

SUMMARY STATEMENT

Background:

In February 2023, the City was made aware of serious safety issues with the widespread practice of Not for Highway Service (NHS) tires being mislabeled and marketed as compliant with Federal Motor Vehicle Safety Standards (FMVSS).

Additional safety concerns have arisen from information published by the major OHV, UTV, and ATV (collectively called "OHVs") manufacturers (Can-Am, Honda, Kawasaki, Polaris, Yamaha, etc.). The owners' manuals and/or certificates of origin on OHVs clearly state that they should never be used and/or that it is hazardous to operate them on paved or public roads. Some even state they are not to be registered for on-road use. OHVs do not have standard FMVSS safety equipment designed to keep passengers safe like: airbags, anti-lock brakes, crumple zones, stability control, and bumpers. Safety testing of OHVs, UTVs, and ATVs is generally completed on dirt roads using NHS tires and not on paved roads or with DOT approved tires.

Additionally, there have been four rollover OHV accidents within City limits in the past 3 years. See Exhibit B.

The major OHV manufacturers sponsor and are members of the Specialty Vehicle Institute of America (SVIA for ATVs) and Recreational Off-Highway Vehicle Association (ROHVA for OHVs/UTVs). ROHVA is an American National Standards Institute accredited not-for-profit trade association that develops equipment, configuration, and performance standards for off-highway vehicles. It was formed to promote the safe and responsible use of off-highway vehicles.

ROHVA's position is that OHVs and UTVs "are designed, manufactured and sold for off-highway use only." ROHVA supports efforts to limit on-road use of OHVs. See Exhibit C.

This is the third public meeting on this issue.

Potential Voluntary Agreement:

City officials and staff have discussed a potential voluntary agreement with the local OHV rental companies to reduce the City's and resident's safety concerns. Some potential elements of the voluntary agreement include:

1. OHV rental companies would install the following safety equipment on their OHV fleets:
 - a. Turn signal indicators
 - b. Vehicle speed governors
 - c. Safety flags
 - d. GPS monitors
 - e. Quieter mufflers
2. OHV rental companies will support limits, guided tours, and permitting on local off-road trails.
3. OHV rental companies will continue to educate each customer on environmental and safety issues with OHVs, including on paved/public roads.
4. OHV rental companies will work with GSRC, RROCC and USFS with trail maintenance, signage, and correcting damaging OHV behavioral trends among all OHV users.

Improper Vehicle Equipment Ordinance:

The proposed ordinance is attached as Exhibit A. Based on the above safety concerns and others outlined in previous Council meetings, the ordinance would make it unlawful to drive, on a paved public road within the City of Sedona, a motor vehicle that is unsafe, does not proper safety equipment, including in violation of FMVSS, or that is not approved by the manufacturer to be operated on paved or public roads.

The first violation would result in a warning or repair order. Failure to repair the equipment violation or a second violation would result in a civil fine not to exceed \$500. A third or subsequent violation of the ordinance would be a Class 1 Misdemeanor.

Climate Action Plan/Sustainability Consistent: Yes - No - Not Applicable

Board/Commission Recommendation: Applicable - Not Applicable

Alternative(s): N/A

MOTION

Move to: For discussion/direction only.

ORDINANCE NO. 2023-___

AN ORDINANCE OF THE CITY OF SEDONA, ARIZONA, ADOPTING AN AMENDMENT TO THE CITY CODE TITLE 10 (VEHICLES AND TRAFFIC) BY ADDING CHAPTER 10.30 (IMPROPER MOTOR VEHICLE EQUIPMENT); PROVIDING FOR PENALTIES, A SAVINGS CLAUSE, AND FOR REPEAL OF CONFLICTING ORDINANCES; AND ESTABLISHING AN EFFECTIVE DATE.

WHEREAS, adhering to Federal and State safety regulations related to motor vehicles reduces the chances of serious injury and death; and

WHEREAS, Utility Terrain Vehicles (“UTV”), All Terrain Vehicles (“ATV”), Off Highway Vehicles (“OHV”), collectively called “OHVs,” are designed, tested, and manufactured solely for off-road use on non-paved surfaces partly because OHVs are equipped with high centers of gravity and tires that have large ridges on them, making them ill-suited for turning and traction on asphalt surfaces; and

WHEREAS, the Consumer Product Safety Commission recommends persons never ride OHVs on public or paved roads; and

WHEREAS, the National Highway Traffic Safety Administration (“NHTSA”) has said, “The use on public roads of off-road vehicles and tires that do not meet the [Federal Motor Vehicle Safety Standards] FMVSS places occupants and other road users at a greater risk of harm”; and

WHEREAS, the United States Department of Transportation (“DOT”) has said, “We share [the City of Sedona’s] concern about the operation of off-road vehicles on public roads. NHTSA has developed various FMVSS over the years through research and testing to establish minimum safety standards for vehicles and equipment intended for use on public roads. The use of off-road vehicles and tires on public roads, which do not meet those minimum safety standards, places the occupants and other road users at a greater risk of crashes and injury or death in a crash”; and

WHEREAS, all manufacturers of OHVs are sponsors and members of the Recreational Off-Highway Vehicle Association (“ROHVA”) and the Specialty Vehicle Institute of America (“SVIA”), and both ROHVA and SVIA urge that on-highway use of OHVs be prohibited and that law enforcement efforts be strengthened to eliminate the dangerous practice of on road use and sponsor model legislation that prohibits OHV use on any public street, road, or highway and as recently as March 2023 ROHVA and SVIA lobbied the Oregon legislature in opposition to making OHVs street legal; and

WHEREAS, all manufacturers of OHVs state that OHVs should not be driven and/or that OHVs are unsafe to be driven on paved and/or public roads.

WHEREAS, the ADOT MVD Off-Highway Vehicle Decal Application requires owners of OHVs to certify under penalty of perjury that the OHV “has been modified to meet all applicable safety and equipment requirements of Arizona Revised Statutes Title 28, Chapter 3, Article 16, **as well as all...other federal requirements**” (emphasis added); and further includes the applicant’s acknowledgement that “I understand that I may receive traffic tickets and court fines if local ordinances prohibit operation of this vehicle”; and

WHEREAS, OHVs lack numerous standard FMVSS required for on road motor vehicle use including: airbags, stability control, crumple zones, rear bumpers, and DOT approved tires; and

WHEREAS, every year tire failure causes approximately 11,000 vehicle crashes and 200 deaths nationwide and adhering to DOT tire regulations reduces the chance of tire failure, and according to NHTSA, in 2020 there were 664 traffic fatalities in tire-related crashes; and

WHEREAS, only DOT approved tires are safe to be used in highway service; and

WHEREAS, NHTSA Interpretation 1985-04.16 explains and FMVSS Standard 109 requires that all motor vehicles manufactured after 1948 have DOT approved tires for on road use; and

WHEREAS, OHVs are equipped with Not for Highway Service (NHS) tires and no OHV tires are currently DOT approved for highway or on street use (see NHTSA June 3, 2022 letter re: Improper Certification of UTV/ATV Tires to FMVSS; U.S. Tire Manufacturers Tire Information Service Bulletin TISB 07); and

WHEREAS, visitors to the City rent OHVs to be driven on paved public roads largely unaware of the foregoing safety concerns; and

WHEREAS, statewide, several OHV rental companies have gone out of business because their rental OHVs were wrecked faster than the OHVs could be repaired (Arizona Off-Highway Vehicle Study Committee Meeting July 21, 2023); and

WHEREAS, Sedona has experienced 710 motor vehicle accidents between 2017 and 2021, resulting in 150 injuries and 5 fatalities; and

WHEREAS, in the past three years, there have been four rollover OHV accidents within City limits and in 2021, statewide there were 187 OHVs involved in accidents with 16 fatalities in 2021 resulting in a 8.55% fatality rate; and

WHEREAS, OHVs are the third leading cause of injury in children in Arizona (Arizona Off-Highway Vehicle Study Committee Meeting July 21, 2023); and

WHEREAS, plaintiffs routinely make claims against the City of Sedona for allowing or maintaining unsafe highway or road conditions; and

WHEREAS, traffic accidents and traffic congestion is a serious concern in the City and the City spends millions of dollars annually to improve traffic safety and congestion believes requiring safe motor vehicles on paved public roads will further improve safety; and

WHEREAS, A.R.S. §28-626(B)(3) delegates motor vehicle safety enforcement to municipalities stating that municipalities “**shall** adopt ordinances or regulations relating to the control and movement of traffic...” (emphasis added); and

WHEREAS, pursuant to A.R.S. §28-1174(B), the City of Sedona has never indicated by rule or regulation that its highways or streets are open; and

WHEREAS, the City finds that driving OHVs on paved or public roads in contravention to their design and the manufacturer recommendation constitutes reckless disregard for the safety of persons and property pursuant to A.R.S. §28-1174(A)(1); and

WHEREAS, the City deems it necessary to adopt certain OHV restrictions and certain regulations regarding improper motor vehicle equipment to protect the health, safety, and welfare of the City residents and travelling public.

BE IT ORDAINED BY THE MAYOR AND CITY COUNCIL OF THE CITY OF SEDONA, ARIZONA, as follows:

Section 1. Amendment of Sedona City Code Title 10 (Vehicles and Traffic)

Title 10 (Vehicles and Traffic) of the City Code of the City of Sedona is hereby amended by adding the following Chapter:

Chapter 10.30 – IMPROPER MOTOR VEHICLE EQUIPMENT

10.30.010 - Definitions.

In this chapter unless the context otherwise requires:

"Driver" means a person who drives or is in actual physical control of a motor vehicle.

"Highway" or "road" mean the entire width between the boundary lines of every paved street or way if a part of the street or way is open to the use of the public for purposes of motor vehicle travel.

"Manufacturer" means a person or entity—

- (A) manufacturing or assembling motor vehicles or motor vehicle equipment; or
- (B) importing motor vehicles or motor vehicle equipment for resale.

"Motor vehicle" means a self-propelled vehicle, including OHVs. It does not include electric bicycles, motorized wheelchairs, or an electric mobility assist device.

"Off-highway Vehicle" or "OHV" means a self-propelled vehicle that is designed and manufactured primarily for off-highway use. It includes Utility Terrain Vehicles, All Terrain Vehicles, Off Highway Vehicles (collectively "OHVs"). It does not include electric bicycles, motorized wheelchairs, or an electric mobility assist device.

"Owner" means the person in whose name such motor vehicle is registered.

"Public employees" means any federal, state, county, or City employees.

"State or Federal motor vehicle safety standards" means all motor vehicle standards listed in A.R.S. Title 28 or the Federal motor vehicle safety standards ("FMVSS") contained in Title 49 of the Code of Federal Regulations.

10.30.020 – Operating Motor Vehicle with Improper Motor Vehicle Equipment Prohibited.

1. A person shall not drive or operate on a highway or road a motor vehicle that:
 - A. Is in an unsafe condition that endangers a person.
 - B. Does not contain those parts or is not at all times equipped with lamps and other equipment in proper condition and adjustment as required in this chapter.
 - C. Is not equipped in the manner required by State or Federal motor vehicle safety standards for motor vehicles that are intended for on-highway operation.
 - D. Is not intended to be used, is unsafe, or is not designed or approved by the manufacturer to be operated on highways or roads as declared in the motor vehicle's certificate of origin or owner's manual.
2. An owner shall not drive or operate or rent to or allow a person to drive or operate on a highway or road the owner's motor vehicle that:
 - A. Is in an unsafe condition that endangers a person.
 - B. Does not contain those parts or is not at all times equipped with lamps and other equipment in proper condition and adjustment as required in this chapter.
 - C. Is not equipped in the manner required by State or Federal motor vehicle safety standards for motor vehicles that are intended for on-highway operation.
 - D. Is not intended to be used, is unsafe, or is not designed or approved by the manufacturer to be operated on highways or roads as declared in the motor vehicle's certificate of origin or owner's manual.
3. For purposes of this section, a motor vehicle is deemed to be in an unsafe condition that endangers a person if it is equipped with tires that do not contain the DOT tire symbol that reflects compliance with FMVSS contained in 49 C.F.R. §574.5.

10.30.030 – Applicability; Closure of Highways to Certain Vehicles; Exceptions.

1. This chapter applies to all highways and roads within the Sedona City limits.
2. Pursuant to A.R.S. 28-1174(A)(3), all highways and roads within the Sedona City limits are closed

to OHV use.

3. This chapter does not apply to:
 - A. Public employees or their designees in the performance of their official duties with appropriate safety training, or to any motor vehicle owned or operated by any federal, state, or local governmental entity.
 - B. Motor vehicles manufactured prior to 1948.

10.30.40 – Inspections.

If at any time there is reasonable cause to believe that a motor vehicle is unsafe or is not equipped as required by this chapter or that a vehicle's equipment is not in proper adjustment or repair, any peace officer may require the driver of the motor vehicle to stop and submit the vehicle to an inspection and such test with reference to the inspection as may be appropriate.

10.30.050 – Authority to Impound Vehicles.

Vehicles operated in violation of this chapter may be impounded in the same manner as provided for by the provisions of SCC 10.15.150.

10.30.060 – Enforcement; Liability.

1. Any AZPOST certified peace officer may issue a written warning or citation for the violation of this chapter.
2. Persons Liable. If any motor vehicle is found in violation of any provision of this chapter, the owner, the person in whose name such motor vehicle is registered, as well as the driver of the vehicle at the time of the violation, shall be jointly and severally responsible for such violation and are subject to the penalties therefor. If the vehicle is not attended by a driver, the owner, or person in whose name such vehicle is registered, shall be held prima facie responsible for such violation and is subject to the penalties therefor. Proof that a person other than the owner was operating the vehicle at the time of the violation shall not constitute a valid defense to the offense.

10.30.070 - Separate Offenses.

Each violation pursuant to this chapter shall constitute a separate offense and each day a violation remains unabated may constitute a separate offense.

10.30.080 - Penalties.

- A. Upon a first violation of this chapter with the motor vehicle, an officer shall issue a written warning or repair order. If a repair order is issued, a certificate of correction or adjustment of illegal or faulty equipment shall be obtained by the owner and shown to the police department within 14 days.
- B. If there is a violation of this chapter and the owner fails to provide the City with a certificate of correction or adjustment within 14 days or the person has previously been issued a warning within one hundred eighty (180) days from the date a warning was issued, the violation is a civil offense punishable by a fine not to exceed five hundred dollars (\$500.00), plus any other penalties, assessments or surcharges authorized by law.
- C. If there is a violation of this chapter and the person has previously been convicted two (2) or more times of violating this chapter under subsection B, the new violation is a class 1 misdemeanor, plus any other penalties, assessments or surcharges authorized by law.

Section 3. Savings Clause

If any section, subsection, sentence, clause, phrase, or portion of this Ordinance is for any reason held to be invalid or unconstitutional by the decision of any court of competent jurisdiction, such decision shall not affect the validity of the remainder of this Ordinance.

Section 4. Repeal

All other code provisions, ordinances, or parts of ordinances in conflict with the provisions of this Ordinance are hereby repealed to the extent of such conflict as of the effective date hereof.

Section 5. Effective Date

The effective date of this Ordinance shall be 60 days following adoption by the City Council.

PASSED AND ADOPTED by the Mayor and Council of the City of Sedona, Arizona, this _____ day of _____, 2023.

Scott M. Jablow, Mayor

ATTEST:

JoAnne Cook, CMC, City Clerk

APPROVED AS TO FORM:

Kurt W. Christianson, City Attorney

ARIZONA CRASH REPORT

REPORT ID

Agency Report Number

1 POLICE ONLY - FORWARD COPY TO ADOT TRAFFIC RECORDS SECTION, 064R 206 S. 17TH AVE., PHOENIX, ARIZONA 85007-3233

2 0 0 7 1 7 1 8 0 4 1 3 1 0 0 0 0 9 1 1 Total Number of Sheets 4

COMPLETE THE TRUCKS SUPPLEMENT IF ANY (circle) AND ANY (diamond) ARE CHECKED

3 LOCATION On Highway/Road/Street Schnebly Hill Road/ USFS Road #153

4 Is this a Secondary Collision? If YES, were any of the following 1" responders hit?

Safety Devices (SD) Airbag (AB) Injury Severity (IS) Seating Position

5 DRIVER 1 DL # No Valid License/Permit State AZ Class G End N/A

5 TRAFFIC UNIT NO. 1 DL # No Valid License/Permit State AZ Class G End N/A

6 PASSENGERS Unit # Seat Pos SD AB IS Name Address City State Zip Code

7 VEHICLE DAMAGED AREA(S) - (CIRCLE ALL THAT APPLY)

8 Property Damaged (Other than Vehicles) Owner's Name Address (or Bar Code ID Number)

9 WITNESSES Name SARAH TIETJEN MIKE PARKINSON MATTHEW POWELL

10 CITATION UNIT # A.R.S. NO OR CITY CODE

1 Photos Taken Yes No Photographer's Name, ID Number and Agency Name S. WILLADSEN #888 SEDONA P.D.

ARIZONA CRASH REPORT

REPORT ID

Agency Report Number

1 CONTINUED
POLICE ONLY - FORWARD COPY TO
ADOT TRAFFIC RECORDS SECTION 064R
206 S. 17TH AVE., PHOENIX, ARIZONA 85007-3233

YEAR	MONTH	DAY	HR	NCIC NO	OFFICER ID NO
2007	17	17	1804	1310	000911

20009472

Total Number of Sheets

12 - ROAD SURFACE CONDITION
UNIT #

<input type="checkbox"/> 01 DRY	<input type="checkbox"/> 08 MUD/DIRT/GRAVEL/SAND
<input type="checkbox"/> 02 WET	<input type="checkbox"/> 09 50 OTHER
<input type="checkbox"/> 03 SNOW/SLUSH	<input type="checkbox"/> 10 51 UNKNOWN
<input type="checkbox"/> 04 ICE/FROST	
<input type="checkbox"/> 05 WATER (standing/moving)	

13 - ROAD GRADE
UNIT #

<input type="checkbox"/> 01 LEVEL	<input type="checkbox"/> 03 UPHILL
<input type="checkbox"/> 02 DOWNHILL	<input type="checkbox"/> 04 51 UNKNOWN

14 - RELATION TO JUNCTION

<input type="checkbox"/> 0 NOT JUNCTION RELATED	<input type="checkbox"/> 4 RAILWAY GRADE CROSSING
<input type="checkbox"/> 1 INTERSECTION (within)	<input type="checkbox"/> 7 DRIVEWAY or ALLEY ACCESS
<input type="checkbox"/> 2 INTERSECTION-RELATED	<input type="checkbox"/> 8 50 OTHER
<input type="checkbox"/> 3 ENTRANCE/EXIT RAMP	<input type="checkbox"/> 9 51 UNKNOWN

15 - TRAFFICWAY DESCRIPTION

<input type="checkbox"/> 1 ONE WAY TRAFFICWAY
<input checked="" type="checkbox"/> 2 TWO-WAY, NOT DIVIDED (no median present)
<input type="checkbox"/> 3 TWO-WAY, (NOT DIVIDED) WITH A CONTINUOUS LEFT TURN LANE
<input type="checkbox"/> 4 TWO-WAY, DIVIDED, UNPROTECTED MEDIAN
<input type="checkbox"/> 5 TWO-WAY, DIVIDED, POSITIVE MEDIAN BARRIER
<input type="checkbox"/> 6 51 UNKNOWN

16 - TRAFFIC CONTROL DEVICE
UNIT #

<input checked="" type="checkbox"/> 0 NO CONTROLS	<input type="checkbox"/> 7 PERSON (law enforcement, crossing guard, flagger, etc.)
<input type="checkbox"/> 1 SIGNAL	<input type="checkbox"/> 8 TRAFFIC CIRCLE / ROUNDABOUT
<input type="checkbox"/> 2 STOP SIGN	<input type="checkbox"/> 9 PEDESTRIAN HYBRID BEACON/HAWK
<input type="checkbox"/> 3 YIELD SIGN	<input type="checkbox"/> 10 50 OTHER
<input type="checkbox"/> 4 WARNING SIGN	<input type="checkbox"/> 11 51 UNKNOWN
<input type="checkbox"/> 5 RAILROAD CROSSING SIGN	
<input type="checkbox"/> 6 FLASHING TRAFFIC SIGNAL	

17 - MANNER OF CRASH IMPACT

<input checked="" type="checkbox"/> 1 SINGLE VEHICLE	<input type="checkbox"/> 6 SIDESWIPE, SAME DIRECTION
<input type="checkbox"/> 2 ANGLE (front to side) (other than left turn)	<input type="checkbox"/> 7 SIDESWIPE, OPPOSITE DIRECTION
<input type="checkbox"/> 3 LEFT TURN	<input type="checkbox"/> 8 U-TURN
<input type="checkbox"/> 4 REAR END (front-to-rear)	<input type="checkbox"/> 9 50 OTHER
<input type="checkbox"/> 5 HEAD-ON (front-to-front) (other than left turn)	<input type="checkbox"/> 10 51 UNKNOWN

18 - DIRECTION OF UNIT TRAVEL (Compass)
BEFORE 1ST CRASH EVENT
UNIT #

<input type="checkbox"/> 01 NORTH	<input type="checkbox"/> 06 NORTHEAST
<input type="checkbox"/> 02 SOUTH	<input type="checkbox"/> 07 SOUTHWEST
<input type="checkbox"/> 03 EAST	<input type="checkbox"/> 08 SOUTHEAST
<input checked="" type="checkbox"/> 04 WEST	<input type="checkbox"/> 09 51 UNKNOWN
<input type="checkbox"/> 05 NORTHWEST	

NOTE: FOR PARKED OR STOPPED VEHICLES, INDICATE THE DIRECTION THE VEHICLE WAS FACING AT THE TIME OF THE CRASH

19 - CONTRIBUTING CIRCUMSTANCES
UP TO TWO CHOICES PER UNIT
UNIT #

0 NO CONTRIBUTING CIRCUMSTANCE

ENVIRONMENTAL

1 GLARE

A. SUNLIGHT

2 PHYSICAL OBSTRUCTION(S)

C. LOAD ON VEHICLE

D. TREE/SHRUB/BUSH

ROAD

3 ROAD SURFACE CONDITION

4 DEBRIS

5 WORK ZONE

6 OBSTRUCTION IN ROADWAY

7 CHANGING ROAD WIDTH

8 NON-HIGHWAY WORK

MOTOR VEHICLE

12 TRES

50 OTHER

51 UNKNOWN

POSSIBLE ROAD RAGE INCIDENT

20 - DISTRACTED DRIVING BEHAVIOR
UNIT #

<input type="checkbox"/> 0 NOT DISTRACTED (NOT APPLICABLE)
<input type="checkbox"/> 1 TALKING ON HANDS FREE DEVICE
<input type="checkbox"/> 2 TALKING ON HAND HELD DEVICE
<input type="checkbox"/> 3 PASSENGER
<input type="checkbox"/> 4 OTHER ACTIVITY, ELECTRONIC DEVICE
<input type="checkbox"/> 5 MANUALLY OPERATING AN ELECTRONIC DEVICE
<input type="checkbox"/> 6 OTHER INSIDE THE VEHICLE (eating, drinking, etc.)
<input type="checkbox"/> 7 OUTSIDE THE VEHICLE (includes unspecified distractions)
<input type="checkbox"/> 8 50 DISTRACTED, UNKNOWN REASON
<input type="checkbox"/> 9 51 UNKNOWN IF DISTRACTED

21 - CONDITION INFLUENCING DRIVER/PEDESTRIAN/CYCLIST
UP TO THREE CHOICES PER UNIT
UNIT #

<input type="checkbox"/> 0 NO APPARENT INFLUENCE	<input type="checkbox"/> 11 ILLNESS OR PHYSICAL IMPAIRMENT
<input type="checkbox"/> 1 BELLASLEEP/FATIGUED	<input type="checkbox"/> 12 ALCOHOL
<input type="checkbox"/> 2 ILLNESS OR PHYSICAL IMPAIRMENT	<input type="checkbox"/> 13 ILLNESS OR PHYSICAL IMPAIRMENT
<input type="checkbox"/> 3 FELL ASLEEP/FATIGUED	<input type="checkbox"/> 14 ILLNESS OR PHYSICAL IMPAIRMENT
<input type="checkbox"/> 4 ALCOHOL	<input type="checkbox"/> 15 ILLNESS OR PHYSICAL IMPAIRMENT
<input type="checkbox"/> 5 ILLNESS OR PHYSICAL IMPAIRMENT	<input type="checkbox"/> 16 ILLNESS OR PHYSICAL IMPAIRMENT
<input type="checkbox"/> 6 MEDICATIONS	<input type="checkbox"/> 17 ILLNESS OR PHYSICAL IMPAIRMENT
<input type="checkbox"/> 7 MARIJUANA	<input type="checkbox"/> 18 ILLNESS OR PHYSICAL IMPAIRMENT
<input type="checkbox"/> 8 MED MARIJUANA CARD PRESENTED	<input type="checkbox"/> 19 ILLNESS OR PHYSICAL IMPAIRMENT
<input type="checkbox"/> 9 50 OTHER	<input type="checkbox"/> 20 ILLNESS OR PHYSICAL IMPAIRMENT
<input type="checkbox"/> 10 ILLNESS OR PHYSICAL IMPAIRMENT	<input type="checkbox"/> 21 ILLNESS OR PHYSICAL IMPAIRMENT
<input type="checkbox"/> 11 ILLNESS OR PHYSICAL IMPAIRMENT	<input type="checkbox"/> 22 ILLNESS OR PHYSICAL IMPAIRMENT
<input type="checkbox"/> 12 ILLNESS OR PHYSICAL IMPAIRMENT	<input type="checkbox"/> 23 ILLNESS OR PHYSICAL IMPAIRMENT
<input type="checkbox"/> 13 ILLNESS OR PHYSICAL IMPAIRMENT	<input type="checkbox"/> 24 ILLNESS OR PHYSICAL IMPAIRMENT
<input type="checkbox"/> 14 ILLNESS OR PHYSICAL IMPAIRMENT	<input type="checkbox"/> 25 ILLNESS OR PHYSICAL IMPAIRMENT
<input type="checkbox"/> 15 ILLNESS OR PHYSICAL IMPAIRMENT	<input type="checkbox"/> 26 ILLNESS OR PHYSICAL IMPAIRMENT
<input type="checkbox"/> 16 ILLNESS OR PHYSICAL IMPAIRMENT	<input type="checkbox"/> 27 ILLNESS OR PHYSICAL IMPAIRMENT
<input type="checkbox"/> 17 ILLNESS OR PHYSICAL IMPAIRMENT	<input type="checkbox"/> 28 ILLNESS OR PHYSICAL IMPAIRMENT
<input type="checkbox"/> 18 ILLNESS OR PHYSICAL IMPAIRMENT	<input type="checkbox"/> 29 ILLNESS OR PHYSICAL IMPAIRMENT
<input type="checkbox"/> 19 ILLNESS OR PHYSICAL IMPAIRMENT	<input type="checkbox"/> 30 ILLNESS OR PHYSICAL IMPAIRMENT
<input type="checkbox"/> 20 ILLNESS OR PHYSICAL IMPAIRMENT	<input type="checkbox"/> 31 ILLNESS OR PHYSICAL IMPAIRMENT
<input type="checkbox"/> 21 ILLNESS OR PHYSICAL IMPAIRMENT	<input type="checkbox"/> 32 ILLNESS OR PHYSICAL IMPAIRMENT
<input type="checkbox"/> 22 ILLNESS OR PHYSICAL IMPAIRMENT	<input type="checkbox"/> 33 ILLNESS OR PHYSICAL IMPAIRMENT
<input type="checkbox"/> 23 ILLNESS OR PHYSICAL IMPAIRMENT	<input type="checkbox"/> 34 ILLNESS OR PHYSICAL IMPAIRMENT
<input type="checkbox"/> 24 ILLNESS OR PHYSICAL IMPAIRMENT	<input type="checkbox"/> 35 ILLNESS OR PHYSICAL IMPAIRMENT
<input type="checkbox"/> 25 ILLNESS OR PHYSICAL IMPAIRMENT	<input type="checkbox"/> 36 ILLNESS OR PHYSICAL IMPAIRMENT
<input type="checkbox"/> 26 ILLNESS OR PHYSICAL IMPAIRMENT	<input type="checkbox"/> 37 ILLNESS OR PHYSICAL IMPAIRMENT
<input type="checkbox"/> 27 ILLNESS OR PHYSICAL IMPAIRMENT	<input type="checkbox"/> 38 ILLNESS OR PHYSICAL IMPAIRMENT
<input type="checkbox"/> 28 ILLNESS OR PHYSICAL IMPAIRMENT	<input type="checkbox"/> 39 ILLNESS OR PHYSICAL IMPAIRMENT
<input type="checkbox"/> 29 ILLNESS OR PHYSICAL IMPAIRMENT	<input type="checkbox"/> 40 ILLNESS OR PHYSICAL IMPAIRMENT
<input type="checkbox"/> 30 ILLNESS OR PHYSICAL IMPAIRMENT	<input type="checkbox"/> 41 ILLNESS OR PHYSICAL IMPAIRMENT
<input type="checkbox"/> 31 ILLNESS OR PHYSICAL IMPAIRMENT	<input type="checkbox"/> 42 ILLNESS OR PHYSICAL IMPAIRMENT
<input type="checkbox"/> 32 ILLNESS OR PHYSICAL IMPAIRMENT	<input type="checkbox"/> 43 ILLNESS OR PHYSICAL IMPAIRMENT
<input type="checkbox"/> 33 ILLNESS OR PHYSICAL IMPAIRMENT	<input type="checkbox"/> 44 ILLNESS OR PHYSICAL IMPAIRMENT
<input type="checkbox"/> 34 ILLNESS OR PHYSICAL IMPAIRMENT	<input type="checkbox"/> 45 ILLNESS OR PHYSICAL IMPAIRMENT
<input type="checkbox"/> 35 ILLNESS OR PHYSICAL IMPAIRMENT	<input type="checkbox"/> 46 ILLNESS OR PHYSICAL IMPAIRMENT
<input type="checkbox"/> 36 ILLNESS OR PHYSICAL IMPAIRMENT	<input type="checkbox"/> 47 ILLNESS OR PHYSICAL IMPAIRMENT
<input type="checkbox"/> 37 ILLNESS OR PHYSICAL IMPAIRMENT	<input type="checkbox"/> 48 ILLNESS OR PHYSICAL IMPAIRMENT
<input type="checkbox"/> 38 ILLNESS OR PHYSICAL IMPAIRMENT	<input type="checkbox"/> 49 ILLNESS OR PHYSICAL IMPAIRMENT
<input type="checkbox"/> 39 ILLNESS OR PHYSICAL IMPAIRMENT	<input type="checkbox"/> 50 ILLNESS OR PHYSICAL IMPAIRMENT
<input type="checkbox"/> 40 ILLNESS OR PHYSICAL IMPAIRMENT	<input type="checkbox"/> 51 ILLNESS OR PHYSICAL IMPAIRMENT

24 - LOCATION OF PEDESTRIAN/CYCLIST
UNIT #

<input type="checkbox"/> 01 AT INTERSECTION IN MARKED CROSSWALK	<input type="checkbox"/> 10 BICYCLE LANE
<input type="checkbox"/> 02 AT INTERSECTION UNMARKED/UNKNOWN IF MARKED CROSSWALK	<input type="checkbox"/> 11 SHOULDER/ROADSIDE
<input type="checkbox"/> 03 AT INTERSECTION NOT IN CROSSWALK	<input type="checkbox"/> 12 SIDEWALK
<input type="checkbox"/> 04 AT INTERSECTION UNKNOWN LOCATION	<input type="checkbox"/> 13 MEDIAN/CROSSING ISLAND
<input type="checkbox"/> 05 NOT AT INTERSECTION IN MARKED CROSSWALK	<input type="checkbox"/> 14 DRIVEWAY ACCESS
<input type="checkbox"/> 06 NOT AT INTERSECTION ON ROADWAY, NOT IN MARKED CROSSWALK	<input type="checkbox"/> 15 SHARED-USE PATH
<input type="checkbox"/> 07 NOT AT INTERSECTION ON ROADWAY, CROSSWALK AVAILABILITY UNKNOWN	<input type="checkbox"/> 16 NON-TRAFFICWAY AREA
<input type="checkbox"/> 08 SCHOOL CROSSWALK	<input type="checkbox"/> 17 50 OTHER
<input type="checkbox"/> 09 PARKING LANE/ZONE	<input type="checkbox"/> 18 51 UNKNOWN LOCATION

25 - ROADWAY ALIGNMENT
UNIT #

<input checked="" type="checkbox"/> 01 STRAIGHT	<input type="checkbox"/> 03 CURVE RIGHT
<input type="checkbox"/> 02 CURVE LEFT	<input type="checkbox"/> 04 51 UNKNOWN

26 - LANE
Please enter unit's number and lane of travel before first crash event

UNIT #	LANE
49	

0 TWO-WAY CONTINUOUS LEFT TURN
1-9 FIRST LANE NEXT TO A MEDIAN THRU 9
10 CROSSWALK
L1 THRU LX - LEFT TURN ONLY LANES (L1 = 1ST LEFT TURN AFTER MEDIAN/CENTERLINE)
R1 THRU RX - RIGHT TURN LANES (R1 = 1ST RIGHT TURN AFTER THROUGH LANES)
SW SIDEWALK
BL DEDICATED BIKE LANE
HOV HIGH OCCUPANCY VEHICLE
49 NON-ROADWAY
50 OTHER
51 UNKNOWN

27 - SEQUENCE OF EVENTS
UP TO FOUR CRASH EVENTS FOR EACH UNIT IN THE ORDER OF OCCURRENCE

NON-COLLISION

- OVERTURN/ROLLOVER
- FIRE/EXPLOSION
- CARGO/EQUIPMENT LOSS/SHIFT
- FELL/JUMPED FROM VEHICLE
- OTHER NON-COLLISION
- EQUIPMENT FAILURE (w/brakes)
- SEPARATION OF UNITS
- RAN OFF ROAD RIGHT
- RAN OFF ROAD LEFT
- CROSS MEDIAN
- CROSS CENTERLINE
- DOWNHILL RUNAWAY

COLLISION WITH PERSON, MOTOR VEHICLE, OR NON-FIXED OBJECT

- MOTOR VEHICLE IN TRANSPORT
- PEDESTRIAN
- PEDALCYCLE
- TRAIN
- LIGHT RAILWAY/RAILCAR VEHICLE
- ANIMAL
- PARKED MOTOR VEHICLE
- STRUCK BY FALLING SHIFTING CARGO OR ANYTHING SET IN MOTION BY ANOTHER VEHICLE
- OTHER NON-FIXED OBJ

BLOCKS 12 - 26: CHECK ONLY ONE OR ONE BLOCK PER UNIT UNLESS NOTED

22 - VIOLATIONS/BEHAVIOR
CHECK ALL THAT APPLY
UNIT #

<input type="checkbox"/> 01 NO IMPROPER ACTION	<input type="checkbox"/> 11 PASSED IN NO PASSING ZONE
<input type="checkbox"/> 02 SPEED TOO FAST FOR CONDITIONS	<input type="checkbox"/> 12 UNSAFE LANE CHANGE
<input type="checkbox"/> 03 EXCEEDED LAWFUL SPEED	<input type="checkbox"/> 13 FAILED TO KEEP IN PROPER LANE
<input type="checkbox"/> 04 FOLLOWED TOO CLOSELY	<input type="checkbox"/> 14 DID NOT USE CROSSWALK
<input type="checkbox"/> 05 RAN STOP SIGN	<input type="checkbox"/> 15 FAILED TO YIELD RIGHT-OF-WAY
<input type="checkbox"/> 06 DISREGARDED TRAFFIC SIGNAL	<input type="checkbox"/> 16 AGGRESSIVE DRIVING
<input type="checkbox"/> 07 MADE IMPROPER TURN	<input type="checkbox"/> 17 50 OTHER off roadway
<input type="checkbox"/> 08 DROVE LEFT OF CENTER LINE	<input type="checkbox"/> 18 51 UNKNOWN
<input type="checkbox"/> 09 WRONG WAY DRIVING	
<input type="checkbox"/> 10 CROSSED MEDIAN	

23 - TRAFFIC UNIT MANEUVER/ACTION
UNIT #

<input type="checkbox"/> 01 GOING STRAIGHT AHEAD	<input type="checkbox"/> 11 AVOIDING VEHICLE/OBJECT/PEDESTRIAN/CYCLIST
<input type="checkbox"/> 02 SLOWING IN TRAFFICWAY	<input type="checkbox"/> 12 ENTERING PARKING POSITION
<input type="checkbox"/> 03 STOPPED IN TRAFFICWAY	<input type="checkbox"/> 13 LEAVING PARKING POSITION
<input type="checkbox"/> 04 MAKING LEFT TURN	<input type="checkbox"/> 14 PROPERLY PARKED
<input type="checkbox"/> 05 MAKING RIGHT TURN	<input type="checkbox"/> 15 IMPROPERLY PARKED
<input type="checkbox"/> 06 MAKING U-TURN	<input type="checkbox"/> 16 MOVING VEHICLE NO DRIVER
<input type="checkbox"/> 07 OVERTAKING/PASSING	<input type="checkbox"/> 17 CROSSING ROAD
<input type="checkbox"/> 08 CHANGING LANES	<input type="checkbox"/> 18 WALKING WITH TRAFFIC
<input type="checkbox"/> 09 NEGOTIATING A CURVE	<input type="checkbox"/> 19 WALKING AGAINST TRAFFIC
<input type="checkbox"/> 10 BACKING	<input type="checkbox"/> 20 STANDING
<input type="checkbox"/> 11 AVOIDING VEHICLE/OBJECT/PEDESTRIAN/CYCLIST	<input type="checkbox"/> 21 LYING
<input type="checkbox"/> 12 ENTERING PARKING POSITION	<input type="checkbox"/> 22 GETTING ON/OFF VEHICLE
<input type="checkbox"/> 13 LEAVING PARKING POSITION	<input type="checkbox"/> 23 50 OTHER
<input type="checkbox"/> 14 PROPERLY PARKED	<input type="checkbox"/> 24 51 UNKNOWN
<input type="checkbox"/> 15 IMPROPERLY PARKED	
<input type="checkbox"/> 16 MOVING VEHICLE NO DRIVER	
<input type="checkbox"/> 17 CROSSING ROAD	
<input type="checkbox"/> 18 WALKING WITH TRAFFIC	
<input type="checkbox"/> 19 WALKING AGAINST TRAFFIC	
<input type="checkbox"/> 20 STANDING	
<input type="checkbox"/> 21 LYING	
<input type="checkbox"/> 22 GETTING ON/OFF VEHICLE	
<input type="checkbox"/> 23 50 OTHER	
<input type="checkbox"/> 24 51 UNKNOWN	

COLLISION WITH FIXED OBJECT

- IMPACT ATTENUATOR/CRASH CUSHION/GUARDRAIL END
- CONCRETE CURB
- GUARDRAIL FACE
- MEDIAN BARRIER
- CABLE BARRIER
- TREE, BUSH, STUMP (standing)
- TRAFFIC SIGNAL SUPPORT
- TRAFFIC SIGNAL SUPPORT
- UTILITY POLE/LIGHT SUPPORT
- FENCE
- OTHER FIXED OBJ.
- UNKNOWN

FIRST HARMFUL EVENT OF THE CRASH _____

SEQUENCE OF EVENTS PER TRAFFIC UNIT

Event	Unit #	Unit
FIRST EVENT	16	
SECOND EVENT	12	
THIRD EVENT	1	
FOURTH EVENT		

ARIZONA CRASH REPORT		REPORT ID										Agency Report Number									
1	CONTINUED		YEAR	MONTH	DAY	HOUR	NCC NO				OFFICER ID NO										
	POLICE ONLY—FORWARD COPY TO ADOT TRAFFIC RECORDS SECTION, 064R 208 S. 17TH AVE. PHOENIX, ARIZONA 85007-3233		2	0	0	7	1	7	1	8	0	4	1	3	1	0	0	0	0	9	1
		CRASH DIAGRAM										<input type="checkbox"/> MEASUREMENTS ARE APPROXIMATE AND NOT TO SCALE <input type="checkbox"/> MEASUREMENTS ARE SCALED (SCALE = _____)									

28			29 INDICATE NORTH

30	NARRATIVE	Describe what happened
<p>On 7/17/2020 at approximately 1804 hours, I was dispatched to an accident with injuries in the Schnebly Hill Road and Huckaby Trail area in Sedona. Dispatch advised us that an ATV with several occupants had rolled over and two of the occupants reportedly had head injuries. The section of road where the wrecked vehicle came to rest was very rocky and was difficult for my police SUV to get to even while carefully maneuvering at a slow pace without striking large rocks. I saw a white and green Razor style off road vehicle rolled onto its driver's side facing westbound that had come to rest on the South side of the road next to the dirt berm. There were several individuals gathered around the vehicle and several other vehicles stopped. Officer Beers approached first and assisted the young male driver who was being held in a c-spine position by a younger female subject. The driver was laying on his back and looked to be unconscious. The driver would later be identified as Matthew Ritchie. I saw a male subject sitting on the berm on the South edge of the road with two other female subjects. This male subject had bright red blood in his hair on the left side of his head. This subject identified himself as Jake McCrackin. I inspected the area where he was bleeding and found a laceration on his scalp that was slowly but actively bleeding. Fire and EMS personnel arrived on scene at approximately 1811 hours. Fire personnel would later state that Matthew would require immediate medical evacuation via helicopter due to a concern about a head or spinal injury. Matthew was transported from the scene to Sedona Emergency Center due to there being no safe area for the helicopter to land and subsequently medevac'd to Flagstaff via helicopter. Jake was also transported to Sedona Medical Center via ambulance for his injuries. I observed several helmets still stuck in the floorboard areas of the vehicle indicating none of the occupants were wearing their protective equipment. I spoke to several witnesses who informed me that they saw the same vehicle traveling at a high rate of speed on the trail. These accounts came from several drivers of the various Jeep Tours in Sedona that frequent this trail, and their concerned passengers. Several vehicles stopped after the scene was completely clear and stated they saw a white and green razor type vehicle occupied by younger male subjects traveling at high rates of speed and passing vehicles on very technical and rocky sections of the road. They stated the vehicle was traveling much faster than what would be reasonable and prudent and felt they and other vehicles were in danger. These witnesses also stated this vehicle was passing other vehicles at high rates of speed and driving up onto the berm of the road which is off the designated roadway. I spoke to one of Matthew's family members, Scott Ritchie. Scott was seated in the passenger side rear seat and also the responsible party for the rental of the vehicle. Scott stated they were traveling westbound at a high rate of speed. Scott stated as they approached the straight section of road, Matthew accelerated into the straightaway. Scott stated Matthew then turned left onto the southern berm to avoid some of the larger rock sections. Scott stated that he believes Matthew over corrected several times when coming off the berm and struck a rock causing the vehicle to roll to the driver's side. he vehicle was still drivable after changing the tire but had substantial visible damage to the body, frame, and some components in the cabin of the vehicle.</p>		

01-2704C R11 17

Case Number: 200009472

Date: 07/18/20

Location: Schnebly Hill Road at approximately 34.865811, -111.746611

Description:



NOT TO SCALE

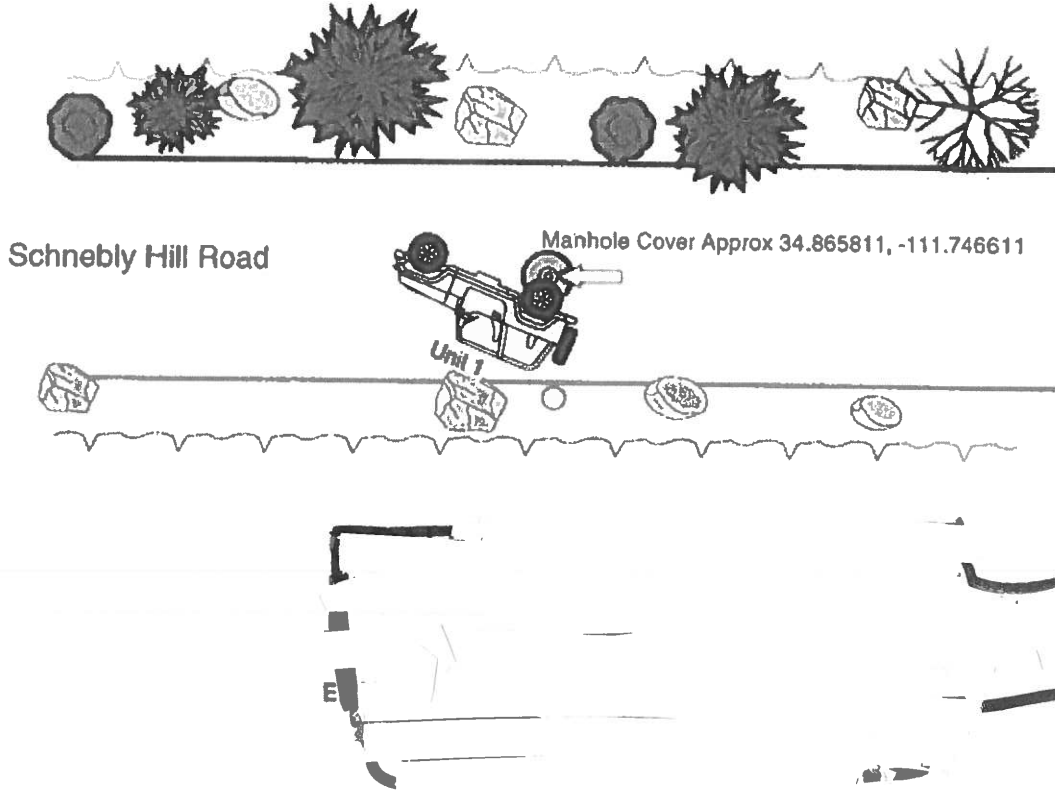

ARIZONA CRASH REPORT		REPORT ID										Agency Report Number																													
1		POLICE ONLY - FORWARD COPY TO ADDI TRAFFIC RECORDS SECTION, 064R 208 S. 17 TH AVE., PHOENIX, ARIZONA 85007-3233		YEAR	MONTH	DAY	HOUR	MIN	SEC	NCK#	NO	OFFICER ID NO	200011614																												
		2	0	0	9	0	5	1	5	0	0	0	3	1	0	0	0	0	9	7	2	Total Number of Sheets	4																		
COMPLETE THE TRUCK/BUS SUPPLEMENT IF ANY (circle) AND ANY (diamond) ARE CHECKED																																									
2		Total Units	1	Total Injures	1	Total Fatalities	0	Estimated Total Damage Compared To \$1,000 Limit: <input checked="" type="checkbox"/> Over <input type="checkbox"/> Under		<input type="radio"/> Fatal <input type="radio"/> Hit/Run Unit #		<input type="radio"/> Person Transported for Immediate Medical Care? <input checked="" type="checkbox"/>		<input type="radio"/> Tow Away of At Least One Vehicle from Scene?		District or Grid No																									
3		LOCATION	On Highway/Road/Street Dry Creek Rd					<input checked="" type="checkbox"/> Inside <input type="checkbox"/> Outside		City		Sedona		County		Yavapai																									
		Intersecting Street/Road/M P or R P of At <input type="checkbox"/> From Gringo Rd					<input type="checkbox"/> North <input type="checkbox"/> East <input type="checkbox"/> Plus <input type="checkbox"/> South <input type="checkbox"/> West <input type="checkbox"/> Minus		Distance		<input type="checkbox"/> Measured <input type="checkbox"/> Miles <input checked="" type="checkbox"/> Approximate <input type="checkbox"/> Feet																														
3		Light Condition					Weather Conditions																																		
		<input type="checkbox"/> 1 Daylight <input type="checkbox"/> 2 Dawn <input type="checkbox"/> 3 Dusk <input type="checkbox"/> 4 Dark - Lighted <input type="checkbox"/> 5 Dark - Not Lighted <input type="checkbox"/> 6 Dark - Unknown Lighting <input type="checkbox"/> 7 Unknown					<input type="checkbox"/> 1 Clear <input type="checkbox"/> 2 Cloudy <input type="checkbox"/> 3 Sleet, Hail (freezing rain/drizzle) <input type="checkbox"/> 4 Rain <input type="checkbox"/> 5 Snow or Blowing Snow <input type="checkbox"/> 6 Fog, Smog, Smoke <input type="checkbox"/> 7 Blowing Sand, Soil, Dust <input type="checkbox"/> 8 Fog, Smog, Smoke <input type="checkbox"/> 9 Other <input type="checkbox"/> 10 Unknown																																		
4		Is this a Secondary Collision: <input type="checkbox"/> Yes <input checked="" type="checkbox"/> No					Roadway Clear Time					1		5		0		0		Incident Clear:		1		5		3		7													
5		Safety Devices (SD)					Airbag (AB)					Injury Severity (IS)					Seating Position																								
		<input type="checkbox"/> 0 - Not Applicable <input type="checkbox"/> 1 - None Used <input type="checkbox"/> 2 - Lap Belt <input type="checkbox"/> 3 - Shoulder and Lap Belt <input type="checkbox"/> 4 - Child Restraint System <input type="checkbox"/> 5 - Helmet Used <input type="checkbox"/> 50 - Other <input type="checkbox"/> 51 - Unknown					<input type="checkbox"/> 0 - Not Applicable <input type="checkbox"/> 1 - Deployed - Front <input type="checkbox"/> 2 - Deployed - Side (Door, seatback) <input type="checkbox"/> 3 - Deployed - Curtain (roof) <input type="checkbox"/> 4 - Deployed - Other (Infla. airbelt, etc.) <input type="checkbox"/> 5 - Deployed - Combination <input type="checkbox"/> 6 - Deployed - Unknown Location <input type="checkbox"/> 7 - Not Deployed					<input type="checkbox"/> 1 - No Injury <input type="checkbox"/> 2 - Possible Injury <input type="checkbox"/> 3 - Suspected Minor Injury <input type="checkbox"/> 4 - Suspected Serious Injury <input type="checkbox"/> 5 - Fatal Injury <input type="checkbox"/> 51 - Unknown/Not Reported					31 21 11 32 22 12 42 33 23 13 38 28 18 18 - Front Seat - Other (child in Lap) 28 or 38 - Additional passenger in vehicle by row 40 - In enclosed cargo area 41 - In unenclosed cargo area 42 - Riding on Vehicle Exterior 50 - Other 51 - Unknown																								
6		DL # <input type="checkbox"/> No Valid License/Permit					State					Class					End																								
		CA					D					none					<input type="checkbox"/> Driver <input type="checkbox"/> Driverless <input type="checkbox"/> Name (First, Middle, Last) <input type="checkbox"/> ejected <input type="checkbox"/> extricated <input type="checkbox"/> Suffix <input type="checkbox"/> Sex <input type="checkbox"/> male																								
7		Restrictions					Address					City					State					Zip Code					Telephone Number														
		CL					2740 W State Route 89A					Sedona					AZ					86336																			
8		Date of Birth					Owner/Carrier Name					<input type="checkbox"/> Same as Driver <input type="checkbox"/> Gov't Vehicle					Address					City					State					Zip Code					Telephone Number				
		02/28/21					POLARIS EXPERIENCE LLC										2740 W State Route 89A					Sedona					AZ					86336									
9		Color					Vehicle Year					Make					Body Style					Plate Number					State					Plate Mo/Yr					<input type="checkbox"/> Bus (9 or more seats)				
		Black					2020					Polaris					Razer					HSP7MC					AZ					02/28/21					<input checked="" type="checkbox"/>				
10		VIN					Autonomous Veh <input type="checkbox"/> Control Man <input type="checkbox"/> AV <input type="checkbox"/> Unkn <input type="checkbox"/>					Trailer (Other Unit) Plate No					State					Year					GWR/GCWR (Rated) Greater Than 10k pounds? <input type="checkbox"/> Yes <input checked="" type="checkbox"/> No					HazMat Placard? <input type="checkbox"/> Yes <input checked="" type="checkbox"/> No									
		3NSASE877LH953620																																							
11		Safety Devices					Airbag					Injury Severity					Posted Speed Limit					Otc Est Speed					Injured Transported To/By														
		3					0					3					25					+25					refused medical treatment														
12		Vehicle Removed to (Address/Storage Location Identifier)					<input type="checkbox"/> Disabled <input type="checkbox"/> Not Disabled					Vehicle Removed by					Orders of																								
		Sedona ATV Rental- 2740 W SR 89A, Sedona										Sedona ATV Rental					Sedona ATV Rentals																								
13		Insurance Company					Telephone Number					Policy Number					Exp Date																								
		Old Republic Insurance					866-234-9411					MWTB315446					09/01/21																								
14		DL # <input type="checkbox"/> No Valid License/Permit					State					Class					End					<input type="checkbox"/> Driver <input type="checkbox"/> Driverless <input type="checkbox"/> Name (First, Middle, Last) <input type="checkbox"/> ejected <input type="checkbox"/> extricated <input type="checkbox"/> Suffix <input type="checkbox"/> Sex																			
		CA					D					none																													
15		Restrictions					Address					City					State					Zip Code					Telephone Number														
16		Date of Birth					Owner/Carrier Name					<input type="checkbox"/> Same as Driver <input type="checkbox"/> Gov't Vehicle					Address					City					State					Zip Code									
17		Color					Vehicle Year					Make					Body Style					Plate Number					State					Plate Mo/Yr					<input type="checkbox"/> Bus (9 or more seats)				
18		VIN					Autonomous Veh <input type="checkbox"/> Control Man <input type="checkbox"/> AV <input type="checkbox"/> Unkn <input type="checkbox"/>					Trailer (Other Unit) Plate No					State					Year					GWR/GCWR (Rated) Greater Than 10k pounds? <input type="checkbox"/> Yes <input checked="" type="checkbox"/> No					HazMat Placard? <input type="checkbox"/> Yes <input checked="" type="checkbox"/> No									
19		Safety Devices					Airbag					Injury Severity					Posted Speed Limit					Otc Est Speed					Injured Transported To/By														
20		Vehicle Removed to (Address/Storage Location Identifier)					<input type="checkbox"/> Disabled <input type="checkbox"/> Not Disabled					Vehicle Removed by					Orders of																								
21		Insurance Company					Telephone Number					Policy Number					Exp Date																								
22		Unit #	Seat Pos	AB	IS	Name	Address		City	State	Zip Code	Phone	Sex	DOB																											
		1	13	3	0	3	[Diagram]																																		
		<input type="checkbox"/> transported by EMS/Fire <input type="checkbox"/> ejected <input type="checkbox"/> extricated																																							
		<input type="checkbox"/> transported by EMS/Fire <input type="checkbox"/> ejected <input type="checkbox"/> extricated																																							
		<input type="checkbox"/> transported by EMS/Fire <input type="checkbox"/> ejected <input type="checkbox"/> extricated																																							
23		VEHICLE DAMAGED AREA(S) - (CIRCLE ALL THAT APPLY)					Unit #					0 - NONE 10 - UNDERCARRIAGE 51 - UNKNOWN					Unit #					0 - NONE 10 - UNDERCARRIAGE 51 - UNKNOWN																			
							1					[Diagram]					1					[Diagram]																			
24		Property Damaged (Other than Vehicles)					Owner Code					Inventory Tag No																													
							1 - Private (OC) 2 - Public Utility 3 - Federal Government 4 - State of Arizona 5 - County in Arizona 6 - City in Arizona 7 - Tribal Nation 51 - Unknown																																		
25		OC					Owner's Name					Address (or Bar Code ID Number)					City					State					Zip Code					Telephone Number									
							Praston D Lien																																		
26		Name					Address					City					State					Zip Code					Telephone Number					DOB									
27		UNIT #					A.R.S. NO. OR CITY CODE					UNIT #					A.R.S. NO. OR CITY CODE																								
28		Photos Taken					Photographer's Name, ID Number and Agency					Invest At Scene					Date Invest					Time Invest					Fire/EMS Incident No														
		<input checked="" type="checkbox"/> Yes <input type="checkbox"/> No					Officer Catherine Beers #972 Sedona PD					<input checked="" type="checkbox"/> Yes <input type="checkbox"/> No					9/5/20					1500					refused														
29		Officer's Name / Badge #					Supervisor's Signature					Agency Name					Date Completed																								
		Officer Catherine Beers 972										Sedona PD					9/5/20																								

ARIZONA CRASH REPORT

REPORT ID

Agency Report Number

1 CONTINUED POLICE ONLY - FORWARD COPY TO ADOT TRAFFIC RECORDS SECTION, 064R 206 S. 17TH AVE., PHOENIX, ARIZONA 85007-3233

YEAR MONTH DAY HOUR NCIC NO OFFICER ID NO

200011614

Total Number of Sheets 4

12 - ROAD SURFACE CONDITION

- 1 UNIT # 1 01 DRY 02 WET 03 SNOW/SLUSH 04 ICE/FROST 05 WATER (standing/moving) 06 MUD/DIRT/GRAVEL/SAND 07 50 OTHER 08 51 UNKNOWN

13 - ROAD GRADE

- 1 UNIT # 1 01 LEVEL 02 DOWNHILL 03 UPHILL 04 51 UNKNOWN

14 - RELATION TO JUNCTION

- 0 NOT JUNCTION RELATED 1 INTERSECTION (with) 2 INTERSECTION-RELATED 3 ENTRANCE/EXIT RAMP 4 RAILWAY GRADE CROSSING 5 7 DRIVEWAY or ALLEY ACCESS 6 50 OTHER 51 UNKNOWN

15 - TRAFFICWAY DESCRIPTION

- 01 ONEWAY TRAFFICWAY 02 TWO-WAY, NOT DIVIDED (no median present) 03 TWO-WAY, (NOT DIVIDED) WITH A CONTINUOUS LEFT TURN LANE 04 TWO-WAY, DIVIDED, UNPROTECTED MEDIAN 05 TWO-WAY, DIVIDED, POSITIVE MEDIAN BARRIER 51 UNKNOWN

16 - TRAFFIC CONTROL DEVICE

- 0 NO CONTROLS 1 SIGNAL 2 STOP SIGN 3 YIELD SIGN 4 WARNING SIGN 5 RAILROAD CROSSING SIGN 6 FLASHING TRAFFIC SIGNAL 7 PERSON (law enforcement, crossing guard, flagger, etc.) 8 TRAFFIC CIRCLE / ROUNDABOUT 9 PEDESTRIAN HYBRID BEACON/HAWK 50 OTHER 51 UNKNOWN

17 - MANNER OF CRASH IMPACT

- 01 SINGLE VEHICLE 02 ANGLE (front to side) (other than left turn) 03 LEFT TURN 04 REAR END (front-to-rear) 05 HEAD-ON (front-to-front) (other than left turn) 06 SIDESWIPE, SAME DIRECTION 07 SIDESWIPE, OPPOSITE DIRECTION 10 U-TURN 50 OTHER 51 UNKNOWN

18 - DIRECTION OF UNIT TRAVEL (Component)

- 01 NORTH 02 SOUTH 03 EAST 04 WEST 05 NORTHWEST 06 NORTHEAST 07 SOUTHWEST 08 SOUTHEAST 51 UNKNOWN

25 - ROADWAY ALIGNMENT

- 1 UNIT # 1 01 STRAIGHT 02 CURVE LEFT 03 CURVE RIGHT 04 51 UNKNOWN

26 - LANE

Please enter unit's number and lane of travel before first crash event

Table with columns UNIT 1 and UNIT

- 0 TWO-WAY CONTINUOUS LEFT TURN 1-9 1 = FIRST LANE NEXT TO A MEDIAN THRU B CROSSWALK 10 THRU LX - LEFT TURN ONLY LANES (L1 = 1st LEFT TURN AFTER MEDIAN/CENTERLINE) R1 THRU RX - RIGHT TURN LANES (R1 = 1st RIGHT TURN AFTER THROUGH LANES) SW SIDEWALK BL DEDICATED BIKE LANE HOV HIGH OCCUPANCY VEHICLE 49 NON-ROADWAY 50 OTHER 51 UNKNOWN

19 - CONTRIBUTING CIRCUMSTANCES

- UP TO TWO CHOICES PER UNIT 1 UNIT # 1 0 NO CONTRIBUTING CIRCUMSTANCE

ENVIRONMENTAL

- 1 GLARE 2 PHYSICAL OBSTRUCTION(S) 3 A STOPPED/PARKED VEHICLE 4 MOVING VEHICLE 5 LOAD ON VEHICLE 6 TRESSHRUB/BUSH 7 A SUNLIGHT 8 3 ROAD SURFACE CONDITION 9 4 DEBRIS 10 5 WORK ZONE 11 8 OBSTRUCTION IN ROADWAY 12 7 CHANGING ROAD WIDTH 13 8 NON-HIGHWAY WORK

MOTOR VEHICLE

- 12 T RES 50 OTHER 51 UNKNOWN POSSIBLE ROAD RAGE INCIDENT

20 - DISTRACTED DRIVING BEHAVIOR

- 0 NOT DISTRACTED/NOT APPLICABLE 1 TALKING ON HANDS FREE DEVICE 2 TALKING ON HAND HELD DEVICE 3 PASSENGER 4 OTHER ACTIVITY, ELECTRONIC DEVICE 5 MANUALLY OPERATING AN ELECTRONIC DEVICE 6 OTHER INSIDE THE VEHICLE (eating, drinking, etc.) 7 OUTSIDE THE VEHICLE (includes unseated distractions) 50 DISTRACTED, UNKNOWN REASON 51 UNKNOWN IF DISTRACTED

21 - CONDITION INFLUENCING Driver/Ped/Cyclist

- UP TO THREE CHOICES PER UNIT 0 NO APPARENT INFLUENCE 1 LILNESS OR PHYSICAL IMPAIRMENT 2 FELL ASLEEP/FATIGUED 3 ALCOHOL 4 ILLEGAL DRUGS 5 MEDICATIONS 6 MARIJUANA 7 MED MARIJUANA CARD PRESENTED 50 OTHER 51 UNKNOWN CONDITION 21 DRE (check all that apply) a DRE RESPONDED b SUSPECT EVALUATED c SUSPECT ARRESTED

24 - LOCATION OF PEDESTRIAN/CYCLIST

- 01 AT INTERSECTION-IN MARKED CROSSWALK 02 AT INTERSECTION-UNMARKED/UNKNOWN IF MARKED CROSSWALK 03 AT INTERSECTION-NOT IN CROSSWALK 04 AT INTERSECTION-UNKNOWN LOCATION 05 NOT AT INTERSECTION-IN MARKED CROSSWALK 06 NOT AT INTERSECTION-ON ROADWAY, NOT IN MARKED CROSSWALK 07 NOT AT INTERSECTION-ON ROADWAY, CROSSWALK AVAILABILITY UNKNOWN 08 SCHOOL CROSSWALK 09 PARKING LANE/ZONE

27 - SEQUENCE OF EVENTS

UP TO FOUR CRASH EVENTS FOR EACH UNIT IN THE ORDER OF OCCURRENCE

NON-COLLISION

- 1 OVERTURN/ROLLOVER 2 FIRE/EXPLOSION 3 CARGO/EQUIPMENT LOSS/SHIFT 6 FELL/JUMPED FROM VEHICLE 8 OTHER NON-COLLISION 9 EQUIPMENT FAILURE (wres, brakes) 10 SEPARATION OF UNITS 11 RAN OFF ROAD RIGHT 12 RAN OFF ROAD LEFT 13 CROSS MEDIAN 14 CROSS CENTERLINE 15 DOWNHILL RUNAWAY

COLLISION WITH PERSON, MOTOR VEHICLE, OR NON-FIXED OBJECT

- 16 MOTOR VEHICLE IN TRANSPORT 17 PEDESTRIAN 18 PEDALCYCLE 19 TRAIN 20 LIGHT RAILWAY/RAILCAR VEHICLE 21 ANIMAL 25 PARKED MOTOR VEHICLE 27 STRUCK BY FALLING SHIFTING CARGO OR ANYTHING SET IN MOTION BY ANOTHER VEHICLE 28 OTHER NON-FIXED OBJ

BLOCKS 12 - 26: CHECK ONLY ONE OR ONE BLOCK PER UNIT UNLESS NOTED

22 - VIOLATIONS/BEHAVIOR

- CHECK ALL THAT APPLY 01 NO IMPROPER ACTION 02 SPEED TOO FAST FOR CONDITIONS 03 EXCEEDED LAWFUL SPEED 04 FOLLOWED TOO CLOSELY 05 RAN STOP SIGN 06 DISREGARDED TRAFFIC SIGNAL 07 MADE IMPROPER TURN 08 DROVE LEFT OF CENTER LANE 09 WRONG WAY DRIVING 10 CROSSED MEDIAN 11 PASSED IN NO PASSING ZONE 12 UNSAFE LANE CHANGE 13 FAILED TO KEEP IN PROPER LANE 17 DID NOT USE CROSSWALK 20 FAILED TO YIELD RIGHT-OF-WAY 49 AGGRESSIVE DRIVING 50 OTHER 51 UNKNOWN

23 - TRAFFIC UNIT MANEUVER/ACTION

- 01 GOING STRAIGHT AHEAD 02 SLOWING IN TRAFFICWAY 03 STOPPED IN TRAFFICWAY 04 MAKING LEFT TURN 05 MAKING RIGHT TURN 06 MAKING U-TURN 07 OVERTAKING/PASSING 08 CHANGING LANES 09 NEGOTIATING A CURVE 10 BACKING 11 AVOIDING VEHICLE/OBJECT/PED/CYCLIST 12 ENTERING PARKING POSITION 13 LEAVING PARKING POSITION 14 PROPERLY PARKED 15 IMPROPERLY PARKED 16 MOVING VEHICLE - NO DRIVER 17 CROSSING ROAD 18 WALKING WITH TRAFFIC 19 WALKING AGAINST TRAFFIC 20 STANDING 21 LYING 22 GETTING ON/OFF VEHICLE 50 OTHER 51 UNKNOWN

COLLISION WITH FIXED OBJECT

- 29 IMPACT ATTENUATOR/CRASH CUSHION/GUARDRAIL END 33 CONCRETE CURB 36 GUARDRAIL FACE 38 MEDIAN BARRIER 39 CABLE BARRIER 41 TREE, BUSH, STUMP (standing) 42 TRAFFIC SIGN SUPPORT 43 TRAFFIC SIGNAL SUPPORT 44 UTILITY POLE/LIGHT SUPPORT 46 FENCE 50 OTHER FIXED OBJ 51 UNKNOWN

FIRST HARMFUL EVENT OF THE CRASH IS

SEQUENCE OF EVENTS PER TRAFFIC UNIT

Table with columns Unit 1 and Unit

ARIZONA CRASH REPORT

REPORT ID

Agency Report Number

1

CONTINUED

POLICE ONLY—FORWARD COPY TO
ADOT TRAFFIC RECORDS SECTION, 064R
206 S 17TH AVE, PHOENIX, ARIZONA 85007-3233

YEAR	MONTH	DAY	HOUR	NCIC NO	OFFICER ID NO
20	09	05	1500	0310	00972

200011614

28

CRASH DIAGRAM

MEASUREMENTS ARE APPROXIMATE AND NOT TO SCALE
 MEASUREMENTS ARE SCALED (SCALE = _____)

29 INDICATE NORTH

30

NARRATIVE

Describe what happened

On 9/5/20 at 1500 hours, Zachary Alexander Ross was driving vehicle #1; a rented ATV (belonging to Sedona ATV Rentals), on Dry Creek Rd in the area of the cross street of Gringo Rd.

Vehicle #1 was traveling southbound. Vehicle #1 was following too closely and agresively crossed the double yellow line to overtake the vehicle in front of it. Vehicle #1 then realized there was a truck coming northbound. Vehicle #1 then over compensated by pulling hard on the wheel to the right, causing it to roll over.

Vehicle #1 had damage to the entire left side from front to back, including the roll bars and roof.

The driver had apparent minor injuries to his left elbow and upper arm.

The passenger had suspected minor injuries/ contusions.

The driver was not cited based on the totality of the circumstances.

Witness statement provided.

Photos, audio and video added to an L3 case.

Officer Catherine Beers 972
9/5/20 1740 hours

Case Number: 200011614

Date: 09/05/20

Location: Dry Creek Rd & Gringo Rd

Description:

Vehicle roller over due to trying to over take a vehicle/ passing, into oncoming traffic

Gringo Rd

Dry Creek Rd

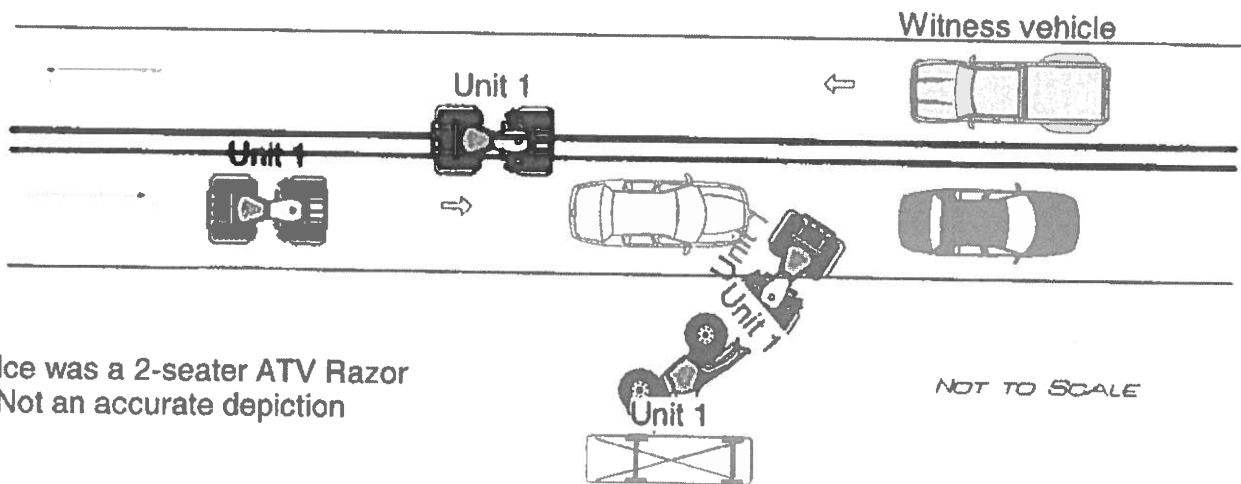

Vehicle was a 2-seater ATV Razor
Not an accurate depiction

NOT TO SCALE



SEDONA POLICE DEPARTMENT
Witness Statement

DR NUMBER
200011614

WITNESS IS Victim Relative Other
SUSPECT NAME (if known)?

LOCATION (STREET, HIGHWAY, MILEPOST, INTERSECTION)

Zachary Alexander Ross

Argus Creek / Girding

NAME, LAST

Lien

FIRST

Treston

MIDDLE

D

CURRENT MAILING ADDRESS

BUSINESS NAME / ADDRESS

CITY

STATE

ZIP CODE

CITY

STATE

ZIP CODE

HOME / CELL PHONE

BUSINESS PHONE

BIRTH DATE (MO/DA/YR)

DRIVER'S LICENSE NUMBER

STATE

SUSPECT DESCRIPTION

RACE: CAUCASIAN BLACK INDIAN HISPANIC ORIENTAL MIDDLE EASTERN OTHER

HEIGHT WEIGHT BUILD: SLIM MEDIUM HEAVY OBESE MUSCULAR OTHER

HAIR: BLACK BROWN RED BLOND GREY OR GREYING BALD OR BALDING

LEIGHT: LONG SHORT SHOULDER CREWCUT STRINGY OILY STRIGHT CURLY

EYES: BLUE BROWN GREEN HAZEL

SIZE: LARGE SMALL FARSET CLOSESET SOUINTY CROSSED BLOODSHOT

GLASSES OR CONTACTS

FACE ROUND OVAL EGG-SHAPED SQUARE NECK: LONG SHORT

MUSTACHE BEARD GOATEE SIDEBURNS CLEAN SHAVEN UNSHAVEN

EYEBROWS: THIN BUSHY JOINED OTHER EARS: LARGE SMALL PROTRUDING

NOSE: THIN LARGE BROKEN PUG WIDE

MOUTH: THIN LIPS FULL LIPS DIMPLES OTHER

TEETH: EVEN SPACED BROKEN MISSING METAL

BREATH: SWEET FOUL ALCOHOL SMOKERS

CHIN: JUTTING RECEDING DIMPLED POINTED SQUARED

COMPLEXION

PALE TANNED COFFEE RED SMOOTH OILY ACNE POCKED FRECKLED

SCARS:

FACE TORSO

LEFT ARM / HAND RIGHT ARM / HAND

TATTOOS:

FACE TORSO

LEFT ARM / HAND RIGHT ARM / HAND

WITNESS INFORMATION

SUSPECT DESCRIPTION

SEDONA POLICE DEPARTMENT
Witness Statement

DR NUMBER

-

SPEECH SLURRED LISP STUTTER CLEFT
PALLET RAPID DRAWL SOFT MUMBLED REFINED ACCENT OTHER

JEWELRY: EARRING(S) _____ WATCH _____

NECKLEACE _____ RINGS _____

CLOTHING NEAT MUSED CLEAN DIRTY MASK / DISGUISE

HAT _____

SCARF _____

SHORT / LONG SLEEVE SHIRT _____

SHORTS / LONG PANTS _____

BELT _____

GLOVES _____

VEST _____

COAT _____

SHOES / BOOTS _____

BAREFOOT _____

JEWELRY: EARRING(S) _____ WATCH _____

NECKLEACE _____ RINGS _____

WEAPON or INSTRUMENT: DESCRIBE, (LENGTH, FINISH, CALIBER, COLOR ETC)

AUTOMATIC: _____

REVOLVER: _____

SHOTGUN _____

RIFLE _____

KNIFE _____

OTHER _____

MODE OF TRAVEL: FOOT BICYCLE VEHICLE: DESCRIBE BELOW _____

DIRECTION OF TRAVEL: _____

WHAT WERE YOU DOING JUST PRIOR TO THE INCIDENT?

WHAT CALLED YOUR ATTENTION TO THE INCIDENT? (BREAKING GLASS, YELLING, SCREAMING, GUN SHOT, ETC)

HOW FAR FROM AWAY FROM INCIDENT WERE YOU WHEN IT OCCURRED?

HOW MANY PEOPLE WERE INVOLVED?

SEDONA POLICE DEPARTMENT
Witness Statement

DR NUMBER

20001641

STATEMENT

Male & female traveling in UTV attempted to
around a vehicle saw other vehicles coming to h
and swerved back into their lane causing the UTV
to roll.

SEDONA POLICE DEPARTMENT
Witness Statement

DR NUMBER

[Empty box for DR NUMBER]

PLEASE DESCRIBE ANY VEHICLES INVOLVED IN THE INCIDENT

VEHICLE	COLOR	MAKE (FORD, CHEVY, ETC.)	MODEL (MUSTANG, CAMARO)	BODY STYLE (STATION WAGON, ETC.)
1				
2				
3				

WEATHER CONDITIONS

CLEAR RAIN SNOW DUST FOG STRONG WINDS CLOUDY OTHER

STATEMENT

[Large area for handwritten statement]

ARIZONA CRASH REPORT

REPORT ID

Agency Report Number

POLICE ONLY - FORWARD COPY TO ADOT TRAFFIC RECORDS SECTION, 064R 208 S. 17TH AVE., PHOENIX, ARIZONA 85007-3233

YEAR MONTH DAY HOUR NCIC NO OFFICER ID NO

220002374

2 2 0 2 2 6 1 7 3 3 0 3 1 0 0 0 0 8 8 5

Total Number of Sheets 5

COMPLETE THE TRUCK/BUS SUPPLEMENT IF ANY (Circle) AND ANY (diamond) ARE CHECKED

Total Units 2 Total Injuries 2 Total Fatalities 0 Estimated Total Damage Compared To \$2,000 Limit Over Under Fatal Hit/Run Person Transported for Immediate Medical Care? Tow Away of At Least One Vehicle from Scene? District or Grid No

LOCATION On Highway/Road/Street Rodeo Rd Intersecting Street/Road/MP or R.P. AI From Bennet Way City Sedona County Yavapai

Light Condition 1 Daylight 2 Dawn 3 Dusk 4 Dark - Lighted 5 Dark - Not Lighted 6 Dark - Unknown Lighting 31 Unknown Weather Conditions 1 Clear 2 Cloudy 3 Sleet, Hail (freezing rain/sleet) 4 Rain 5 Snow or Blowing Snow 6 Blowing Sand, Soil, Dirt 7 Fog 8 Smog 9 Smoke 50 Other 51 Unknown

GLOBAL POSITION Latitude 34.855882 Longitude -113.800003 Is this a Secondary Collision? Yes No If YES, were any of the following 1st responders hit? Law Enforcement Fire EMS Tow Operator DOT Worker Other Roadway Clear Time: 1 7 3 3 Incident Clear: 1 7 3 3

Safety Devices (SD) 0 - Not Applicable 1 - None Used 2 - Lap Belt 3 - Shoulder and Lap Belt 4 - Child Restraint System 5 - Helmet Used 50 - Other 51 - Unknown Airbag (AB) 0 - Not Applicable 1 - Deployed - Front 2 - Deployed - Side (Door, seatback) 3 - Deployed - Curtain (roof) 4 - Deployed - Other (Aire, airbell, etc.) 5 - Deployed - Combination 6 - Deployed - Unknown Location 7 - Not Deployed Injury Severity (IS) 1 - No Injury 2 - Possible Injury 3 - Suspected Minor Injury 4 - Suspected Serious Injury 5 - Fatal Injury 51 - Unknown/Not Reported Seating Position 18 - Front Seat - Other (child in Lap) 28 or 38 - Additional passenger in vehicle by row 40 - In enclosed cargo area 41 - In enclosed cargo area 42 - Riding on Vehicle Exterior 50 - Other 51 - Unknown

TRAFFIC UNIT NO 1 DL# No Valid License/Permit State CA Class NA End NA Driver Pedestrian Driverless Pedalcyclist Name (First, Middle, Last) Mauricio B Moya Ejected Extricated Suffix Sex M Restrictions NA Address City State Zip Code Telephone Number Date of Birth Owner/Carrier Name Same as Driver Gov't Vehicle Address City State Zip Code NO RECORD NO RECORD NO RECORD NA NA Safety Devices 1 Airbag 0 Injury Severity 4 Posted Speed Limit 25 Ofc Est. Speed 50 Injured Transported To/By TAB009 Vehicle Removed to (Address/Storage Location Identifier) Sedona PD Evidence Vehicle Removed by Sedona PD Insurance Company NA Telephone Number NA Policy Number NA Exp Date NA

TRAFFIC UNIT NO 2 DL# No Valid License/Permit State NA Class NA End NA Driver Pedestrian Driverless Pedalcyclist Name (First, Middle, Last) David Nolan Steinecker Ejected Extricated Suffix Sex M Restrictions NA Address City State Zip Code Telephone Number Date of Birth Owner/Carrier Name Same as Driver Gov't Vehicle Address City State Zip Code Color Black Vehicle Year 2012 Make Honda Body Style 4DSD Plate Number CJX7163 State AZ Plate Mo/Yr 11/2022 Bus (8 or more seats) VIN JH1RM3H78CC009954 Autonomous Veh Control Man AV Unk Trailer (Other Unit) Plate No. NA State Year NA NA GWR/GCWR (Rtwd) Greater Than 10k pounds? No HazMat Placard? No Safety Devices 3 Airbag 7 Injury Severity 1 Posted Speed Limit 25 Ofc Est. Speed 15 Injured Transported To/By No Injury Vehicle Removed to (Address/Storage Location Identifier) Sedona PD Evidence Vehicle Removed by Sixmen Towing Insurance Company State Farm Telephone Number 6239742600 Policy Number 361 1430-801-03 Exp Date 02/01/2022

PASSENGERS Unit Seat Pos AB FB Name Address City State Zip Code Phone Sex D.O.B 1 42 1 0 4 transported by EMS/Fire Daniel Moya Ejected Extricated NA M

VEHICLE DAMAGED AREA(S) - (CIRCLE ALL THAT APPLY) 1 Unit # 2 3 4 5 6 0 - NONE 10 - UNDERCARRIAGE 51 - UNKNOWN 2 Unit # 1 2 3 4 5 6 0 - NONE 10 - UNDERCARRIAGE 51 - UNKNOWN

PROPERTY DAMAGED (Other than Vehicles) Owner Code 1 - Private 2 - Public Utility 3 - Federal Government 4 - State of Arizona 5 - County in Arizona 6 - City in Arizona 7 - Tribal Nation 8 - Unknown Inventory Tag No

OC Owner's Name Address (or Bar Code ID Number) City State Zip Code Telephone Number

WITNESSES Name Address City State Zip Code Telephone Number D.O.B.

CITATION UNIT # A.R.S. NO OR CITY CODE UNIT # A.R.S. NO OR CITY CODE

Photos Taken Yes No Photographer's Name, ID Number and Agency Name J. Reed #732 Invest. At Scene Yes No Date Invest 02/26/2022 Time Invest 1733 Fire/EMS Incident No 220000687 Officer's Name / Badge # R. Ramirez #885 Supervisor's Signature Agency Name Sedona PD Date Completed 02/26/2022

ARIZONA CRASH REPORT

REPORT ID

Agency Report Number

1 **CONTINUED**
POLICE ONLY - FORWARD COPY TO
ADOT TRAFFIC RECORDS SECTION 064R
206 S 17TH AVE., PHOENIX, ARIZONA 85007-3233

YEAR	MONTH	DAY	HOUR	NCIC NO.	OFFICER ID NO.
2020	02	02	17:33	0310	000885

220002374

Total Number of Streets 5

12 - ROAD SURFACE CONDITION

UNIT # 1

<input checked="" type="checkbox"/> <input type="checkbox"/> 1 DRY	<input type="checkbox"/> <input type="checkbox"/> 8 MUD/DIRT/GRAVEL/SAND
<input type="checkbox"/> <input type="checkbox"/> 2 WET	<input type="checkbox"/> <input type="checkbox"/> 9 SO OTHER
<input type="checkbox"/> <input type="checkbox"/> 3 SNOW/SLUSH	<input type="checkbox"/> <input type="checkbox"/> 10 ICE/FROST
<input type="checkbox"/> <input type="checkbox"/> 4 WATER (standing/moving)	<input type="checkbox"/> <input type="checkbox"/> 11 UNKNOWN

13 - ROAD GRADE

UNIT # 1

<input type="checkbox"/> <input type="checkbox"/> 1 LEVEL	<input type="checkbox"/> <input type="checkbox"/> 3 UPHILL
<input type="checkbox"/> <input type="checkbox"/> 2 DOWNHILL	<input type="checkbox"/> <input type="checkbox"/> 51 UNKNOWN

14 - RELATION TO JUNCTION

UNIT # 0

<input type="checkbox"/> <input type="checkbox"/> 0 NOT JUNCTION RELATED	<input type="checkbox"/> <input type="checkbox"/> 4 RAILWAY GRADE CROSSING
<input type="checkbox"/> <input type="checkbox"/> 1 INTERSECTION (within)	<input type="checkbox"/> <input type="checkbox"/> 7 DRIVEWAY or ALLEY ACCESS
<input type="checkbox"/> <input type="checkbox"/> 2 INTERSECTION-RELATED	<input type="checkbox"/> <input type="checkbox"/> 50 OTHER
<input type="checkbox"/> <input type="checkbox"/> 3 ENTRANCE/EXIT RAMP	<input type="checkbox"/> <input type="checkbox"/> 51 UNKNOWN

15 - TRAFFICWAY DESCRIPTION

UNIT # 1

<input type="checkbox"/> <input type="checkbox"/> 1 ONE WAY TRAFFICWAY
<input type="checkbox"/> <input type="checkbox"/> 2 TWO-WAY, NOT DIVIDED (no median present)
<input type="checkbox"/> <input type="checkbox"/> 3 TWO-WAY, (NOT DIVIDED) WITH A CONTINUOUS LEFT TURN LANE
<input type="checkbox"/> <input type="checkbox"/> 4 TWO-WAY, DIVIDED UNPROTECTED MEDIAN
<input type="checkbox"/> <input type="checkbox"/> 5 TWO-WAY, DIVIDED POSITIVE MEDIAN BARRIER
<input type="checkbox"/> <input type="checkbox"/> 61 UNKNOWN

16 - TRAFFIC CONTROL DEVICE

UNIT # 0

<input type="checkbox"/> <input type="checkbox"/> 0 NO CONTROLS	<input type="checkbox"/> <input type="checkbox"/> 7 PERSON (law enforcement, crossing guard, flagger etc.)
<input type="checkbox"/> <input type="checkbox"/> 1 SIGNAL	<input type="checkbox"/> <input type="checkbox"/> 8 TRAFFIC CIRCLE / ROUNDABOUT
<input type="checkbox"/> <input type="checkbox"/> 2 STOP SIGN	<input type="checkbox"/> <input type="checkbox"/> 9 PEDESTRIAN HYBRID BEACON/HAWK
<input type="checkbox"/> <input type="checkbox"/> 3 YIELD SIGN	<input type="checkbox"/> <input type="checkbox"/> 50 OTHER
<input type="checkbox"/> <input type="checkbox"/> 4 WARNING SIGN	<input type="checkbox"/> <input type="checkbox"/> 51 UNKNOWN
<input type="checkbox"/> <input type="checkbox"/> 5 RAILROAD CROSSING SIGN	
<input type="checkbox"/> <input type="checkbox"/> 6 FLASHING TRAFFIC SIGNAL	

17 - MANNER OF CRASH IMPACT

UNIT # 1

<input type="checkbox"/> <input type="checkbox"/> 1 SINGLE VEHICLE	<input type="checkbox"/> <input type="checkbox"/> 6 S-DES/WPVE SAME DIRECTION
<input type="checkbox"/> <input type="checkbox"/> 2 ANGLE (front to side) (other than left turn)	<input type="checkbox"/> <input type="checkbox"/> 7 S-DES/WPVE OPPOSITE DIRECTION
<input type="checkbox"/> <input type="checkbox"/> 3 LEFT TURN	<input type="checkbox"/> <input type="checkbox"/> 10 U-TURN
<input type="checkbox"/> <input type="checkbox"/> 4 REAR END (front-to-rear)	<input type="checkbox"/> <input type="checkbox"/> 51 UNKNOWN
<input type="checkbox"/> <input type="checkbox"/> 5 HEAD-ON (front-to-front) (other than left turn)	

18 - DIRECTION OF UNIT TRAVEL (Compass)

BEFORE 1ST CRASH EVENT
UNIT # 1

<input type="checkbox"/> <input type="checkbox"/> 1 NORTH	<input type="checkbox"/> <input type="checkbox"/> 6 NORTHEAST
<input type="checkbox"/> <input type="checkbox"/> 2 SOUTH	<input type="checkbox"/> <input type="checkbox"/> 7 SOUTHWEST
<input type="checkbox"/> <input type="checkbox"/> 3 EAST	<input type="checkbox"/> <input type="checkbox"/> 8 SOUTHEAST
<input type="checkbox"/> <input type="checkbox"/> 4 WEST	<input type="checkbox"/> <input type="checkbox"/> 51 UNKNOWN
<input type="checkbox"/> <input type="checkbox"/> 5 NORTHWEST	

NOTE: FOR PARKED OR STOPPED VEHICLES, INDICATE THE DIRECTION THE VEHICLE WAS FACING AT THE TIME OF THE CRASH

19 - ROADWAY ALIGNMENT

UNIT # 1

<input type="checkbox"/> <input type="checkbox"/> 1 STRAIGHT	<input type="checkbox"/> <input type="checkbox"/> 3 CURVE RIGHT
<input type="checkbox"/> <input type="checkbox"/> 2 CURVE LEFT	<input type="checkbox"/> <input type="checkbox"/> 51 UNKNOWN

20 - LANE

Please enter unit's number and lane of travel before first crash event

UNIT 1	UNIT 2
1	1

- 0 TWO-WAY CONTINUOUS LEFT TURN
- 1-9 1 = FIRST LANE NEXT TO A MEDIAN THRU 9 CROSSWALK
- L1 THRU LX - LEFT TURN ONLY LANES (L1 = 1ST LEFT TURN AFTER MEDIAN/CENTERLINE)
- R1 THRU RX - RIGHT TURN LANES (R1 = 1ST RIGHT TURN AFTER THROUGH LANES)
- SW SIDEWALK
- BL DEDICATED BIKE LANE
- HV HIGH OCCUPANCY VEHICLE
- 49 NON-ROADWAY
- 50 OTHER
- 51 UNKNOWN

19 - CONTRIBUTING CIRCUMSTANCES

UP TO TWO CHOICES PER UNIT
UNIT # 1

0 NO CONTRIBUTING CIRCUMSTANCE

ENVIRONMENTAL

UNIT # 1

<input type="checkbox"/> <input type="checkbox"/> 1 GLARE
<input type="checkbox"/> <input type="checkbox"/> 2 A SUNLIGHT
<input type="checkbox"/> <input type="checkbox"/> 2 PHYSICAL OBSTRUCTION S:
<input type="checkbox"/> <input type="checkbox"/> 2 A STOPPED/PARKED VEHICLE
<input type="checkbox"/> <input type="checkbox"/> 2 B MOVING VEHICLE
<input type="checkbox"/> <input type="checkbox"/> 2 C LOAD ON VEHICLE
<input type="checkbox"/> <input type="checkbox"/> 2 D TREES/SHRUB/BUSH

ROAD

UNIT # 1

<input type="checkbox"/> <input type="checkbox"/> 3 ROAD SURFACE CONDITION
<input type="checkbox"/> <input type="checkbox"/> 4 DEBRIS
<input type="checkbox"/> <input type="checkbox"/> 5 WORK ZONE
<input type="checkbox"/> <input type="checkbox"/> 6 OBSTRUCTION IN ROADWAY
<input type="checkbox"/> <input type="checkbox"/> 7 CHANGING ROAD WIDTH
<input type="checkbox"/> <input type="checkbox"/> 8 NON-HIGHWAY WORK

MOTOR VEHICLE

UNIT # 1

<input type="checkbox"/> <input type="checkbox"/> 12 TIRES
<input type="checkbox"/> <input type="checkbox"/> 50 OTHER
<input type="checkbox"/> <input type="checkbox"/> 51 UNKNOWN

POSSIBLE ROAD RAGE INCIDENT

20 - DISTRACTED DRIVING BEHAVIOR

UNIT # 1

<input type="checkbox"/> <input type="checkbox"/> 0 NOT DISTRACTED/NOT APPLICABLE
<input type="checkbox"/> <input type="checkbox"/> 1 TALKING ON HANDS FREE DEVICE
<input type="checkbox"/> <input type="checkbox"/> 2 TALKING ON HAND HELD DEVICE
<input type="checkbox"/> <input type="checkbox"/> 3 PASSENGER
<input type="checkbox"/> <input type="checkbox"/> 4 OTHER ACTIVITY ELECTRONIC DEVICE
<input type="checkbox"/> <input type="checkbox"/> 5 MANUALLY OPERATING AN ELECTRONIC DEVICE
<input type="checkbox"/> <input type="checkbox"/> 6 OTHER INSIDE THE VEHICLE (eating, drinking, etc.)
<input type="checkbox"/> <input type="checkbox"/> 7 OUTSIDE THE VEHICLE (includes unspecified distractions)
<input type="checkbox"/> <input type="checkbox"/> 50 DISTRACTED, UNKNOWN REASON
<input type="checkbox"/> <input type="checkbox"/> 51 UNKNOWN IF DISTRACTED

21 - CONDITION OF FLUORISCH Driver/Ped/Cyclist

UP TO THREE CHOICES PER UNIT
UNIT # 1

<input type="checkbox"/> <input type="checkbox"/> 0 NO APPARENT INFLUENCE
<input type="checkbox"/> <input type="checkbox"/> 1 ILLNESS OR PHYSICAL IMPAIRMENT
<input type="checkbox"/> <input type="checkbox"/> 2 FELL ASLEEP/FATIGUED
<input type="checkbox"/> <input type="checkbox"/> 3 ALCOHOL
<input type="checkbox"/> <input type="checkbox"/> 4 ILLEGAL DRUGS
<input type="checkbox"/> <input type="checkbox"/> 5 MEDICATIONS
<input type="checkbox"/> <input type="checkbox"/> 6 MEDICATIONS
<input type="checkbox"/> <input type="checkbox"/> 7 MARIJUANA
<input type="checkbox"/> <input type="checkbox"/> 8 MED MARIJUANA CARD PRESENTED
<input type="checkbox"/> <input type="checkbox"/> 50 OTHER
<input type="checkbox"/> <input type="checkbox"/> 51 UNKNOWN CONDITION

21 DRE (check all that apply)

UNIT # 1

<input type="checkbox"/> <input type="checkbox"/> a DRE RESPONDED
<input type="checkbox"/> <input type="checkbox"/> b SUSPECT EVALUATED
<input type="checkbox"/> <input type="checkbox"/> c SUSPECT ARRESTED

24 - LOCATION OF PEDESTRIAN/CYCLIST

UNIT # 1

<input type="checkbox"/> <input type="checkbox"/> 1 AT INTERSECTION-IN MARKED CROSSWALK
<input type="checkbox"/> <input type="checkbox"/> 2 AT INTERSECTION-UNMARKED/UNKNOWN IF MARKED CROSSWALK
<input type="checkbox"/> <input type="checkbox"/> 3 AT INTERSECTION-NOT IN CROSSWALK
<input type="checkbox"/> <input type="checkbox"/> 4 AT INTERSECTION-UNKNOWN LOCATION
<input type="checkbox"/> <input type="checkbox"/> 5 NOT AT INTERSECTION-IN MARKED CROSSWALK
<input type="checkbox"/> <input type="checkbox"/> 6 NOT AT INTERSECTION-ON ROADWAY, NOT IN MARKED CROSSWALK
<input type="checkbox"/> <input type="checkbox"/> 7 NOT AT INTERSECTION-ON ROADWAY, CROSSWALK AVAILABILITY UNKNOWN
<input type="checkbox"/> <input type="checkbox"/> 8 SCHOOL CROSSWALK
<input type="checkbox"/> <input type="checkbox"/> 9 PARKING LANE/ZONE

BLOCKS 12 - 26: CHECK ONLY ONE OR ONE BLOCK PER UNIT UNLESS NOTED

22 - VIOLATIONS/BEHAVIOR

CHECK ALL THAT APPLY
UNIT # 1

<input type="checkbox"/> <input type="checkbox"/> 1 NO IMPROPER ACTION
<input type="checkbox"/> <input type="checkbox"/> 2 SPEED TOO FAST FOR CONDITIONS
<input type="checkbox"/> <input type="checkbox"/> 3 EXCEEDED LAWFUL SPEED
<input type="checkbox"/> <input type="checkbox"/> 4 FOLLOWED TOO CLOSELY
<input type="checkbox"/> <input type="checkbox"/> 5 RAN STOP SIGN
<input type="checkbox"/> <input type="checkbox"/> 6 DISREGARDED TRAFFIC SIGNAL
<input type="checkbox"/> <input type="checkbox"/> 7 MADE IMPROPER TURN
<input type="checkbox"/> <input type="checkbox"/> 8 DROVE LEFT OF CENTER LINE
<input type="checkbox"/> <input type="checkbox"/> 9 WRONG WAY DRIVING
<input type="checkbox"/> <input type="checkbox"/> 10 CROSSED MEDIAN
<input type="checkbox"/> <input type="checkbox"/> 11 PASSED IN NO PASSING ZONE
<input type="checkbox"/> <input type="checkbox"/> 12 UNSAFE LANE CHANGE
<input type="checkbox"/> <input type="checkbox"/> 13 FAILED TO KEEP IN PROPER LANE
<input type="checkbox"/> <input type="checkbox"/> 17 DID NOT USE CROSSWALK
<input type="checkbox"/> <input type="checkbox"/> 20 FAILED TO YIELD RIGHT-OF-WAY
<input type="checkbox"/> <input type="checkbox"/> 49 AGGRESSIVE DRIVING
<input type="checkbox"/> <input type="checkbox"/> 50 OTHER
<input type="checkbox"/> <input type="checkbox"/> 51 UNKNOWN

23 - TRAFFIC UNIT MANEUVER/ACTION

UNIT # 1

<input type="checkbox"/> <input type="checkbox"/> 1 GOING STRAIGHT AHEAD
<input type="checkbox"/> <input type="checkbox"/> 2 SLOWING IN TRAFFICWAY
<input type="checkbox"/> <input type="checkbox"/> 3 STOPPED IN TRAFFICWAY
<input type="checkbox"/> <input type="checkbox"/> 4 MAKING LEFT TURN
<input type="checkbox"/> <input type="checkbox"/> 5 MAKING RIGHT TURN
<input type="checkbox"/> <input type="checkbox"/> 6 MAKING U-TURN
<input type="checkbox"/> <input type="checkbox"/> 7 OVERTAKING/PASSING
<input type="checkbox"/> <input type="checkbox"/> 8 CHANGING LANES
<input type="checkbox"/> <input type="checkbox"/> 9 NEGOTIATING A CURVE
<input type="checkbox"/> <input type="checkbox"/> 10 BACKING
<input type="checkbox"/> <input type="checkbox"/> 11 AVOIDING VEHICLE/OBJECT/PED/CYCLIST
<input type="checkbox"/> <input type="checkbox"/> 12 ENTERING PARKING POSITION
<input type="checkbox"/> <input type="checkbox"/> 13 LEAVING PARKING POSITION
<input type="checkbox"/> <input type="checkbox"/> 14 PROPERLY PARKED
<input type="checkbox"/> <input type="checkbox"/> 15 IMPROPERLY PARKED
<input type="checkbox"/> <input type="checkbox"/> 16 MOVING VEHICLE - NO DRIVER
<input type="checkbox"/> <input type="checkbox"/> 17 CROSSING ROAD
<input type="checkbox"/> <input type="checkbox"/> 18 WALKING WITH TRAFFIC
<input type="checkbox"/> <input type="checkbox"/> 19 WALKING AGAINST TRAFFIC
<input type="checkbox"/> <input type="checkbox"/> 20 STANDING
<input type="checkbox"/> <input type="checkbox"/> 21 LYING
<input type="checkbox"/> <input type="checkbox"/> 22 GETTING ON/OFF VEHICLE
<input type="checkbox"/> <input type="checkbox"/> 50 OTHER
<input type="checkbox"/> <input type="checkbox"/> 51 UNKNOWN

27 - SEQUENCE OF EVENTS

UP TO FOUR CRASH EVENTS FOR EACH UNIT IN THE ORDER OF OCCURRENCE

NON-COLLISION

- 1 OVERTURN/ROLLOVER
- 2 FIRE/EXPLOSION
- 3 CARGO/EQUIPMENT LOSS/SHIFT
- 4 FELL/JUMPED FROM VEHICLE
- 5 OTHER NON-COLLISION
- 6 EQUIPMENT FAILURE (tires, brakes)
- 7 SEPARATION OF UNITS
- 8 RAN OFF ROAD RIGHT
- 9 RAN OFF ROAD LEFT
- 10 CROSS MEDIAN
- 11 DOWNHILL RUNAWAY

COLLISION WITH PERSON, MOTOR VEHICLE, OR NON-FIXED OBJECT

- 16 MOTOR VEHICLE IN TRANSPORT
- 17 PEDESTRIAN
- 18 PEDALCYCLE
- 19 TRAIN
- 20 LIGHT RAILWAY/RAILCAR VEHICLE
- 21 ANIMAL
- 25 PARKED MOTOR VEHICLE
- 27 STRUCK BY FALLING, SHIFTING CARGO OR ANYTHING SET IN MOTION BY ANOTHER VEHICLE
- 28 OTHER NON-FIXED OBJ.

COLLISION WITH FIXED OBJECT

- 29 IMPACT ATTENUATOR/CRASH CUSHION/GUARDRAIL END
- 30 CONCRETE CURB
- 36 GUARDRAIL FACE
- 36 MEDIAN BARRIER
- 39 CABLE BARRIER
- 41 TREE, BUSH, STUMP (standing)
- 42 TRAFFIC SIGN SUPPORT
- 43 TRAFFIC SIGNAL SUPPORT
- 44 UTILITY POLE/LIGHT SUPPORT
- 46 FENCE
- 50 OTHER FIXED OBJ.
- 51 UNKNOWN

FIRST HARMFUL EVENT OF THE CRASH 16

SEQUENCE OF EVENTS PER TRAFFIC UNIT

	Unit 1	Unit 2
FIRST EVENT	16	16
SECOND EVENT		
THIRD EVENT		
FOURTH EVENT		

ARIZONA CRASH REPORT		REPORT ID										Agency Report Number							
1	CONTINUED POLICE ONLY--FORWARD COPY TO ADOT TRAFFIC RECORDS SECTION, 064R 206 S. 17TH AVE. PHOENIX, ARIZONA 85007-3233	YEAR	MONTH		DAY		HOUR		NCIC NO.		OFFICER ID NO.				220002374				
		2	2	0	2	2	6	1	7	3	3	0	3	1		0	0	0	0
28	CRASH DIAGRAM										<input type="checkbox"/> MEASUREMENTS ARE APPROXIMATE AND NOT TO SCALE <input checked="" type="checkbox"/> MEASUREMENTS ARE SCALED (SCALE = _____)				29				
											INDICATE NORTH				7				

30	NARRATIVE	Describe what happened
<p>Driver of Vehicle 1 (ATV) was south bound on Rodeo Rd and Driver of Vehicle 2 was north bound on Rodeo Rd. Driver of Vehicle 2 stated that he observed a rider and passenger on an ATV, Vehicle 1, "out of control and driving left and right of the centerline".</p> <p>Vehicle 1 collided with Vehicle 2 at a front to side angle impacting into the side wheel well and driver's side door. Vehicle 1 overturned on its right side near the roadway double yellow centerline, both driver and passenger were ejected and came to rest behind Vehicle 2.</p> <p>I observed heavy crush damage to the driver's side, front bumper, wheel well and front door.</p> <p>Driver of Vehicle 2 stated he reduced his speed from 25mph to approximately 15mph at the time of impact between both vehicles.</p> <p>Both driver and passenger of Vehicle 1 were transported to Flagstaff Medical Center for serious injuries.</p> <p>Both vehicles were towed to the Sedona PD Evidence Yard.</p>		

Case Number: 220002374

Date: 02/26/22

Location: Bennett Way & Rodeo Rd

Narrative:

A. Manhole Cover used for a permanent point of reference for Longitude and Latitude.

Case Number: 220002374 Date: 02/26/22

Location: Bennett Way & Rodeo Rd

Description:



NOT TO SCALE

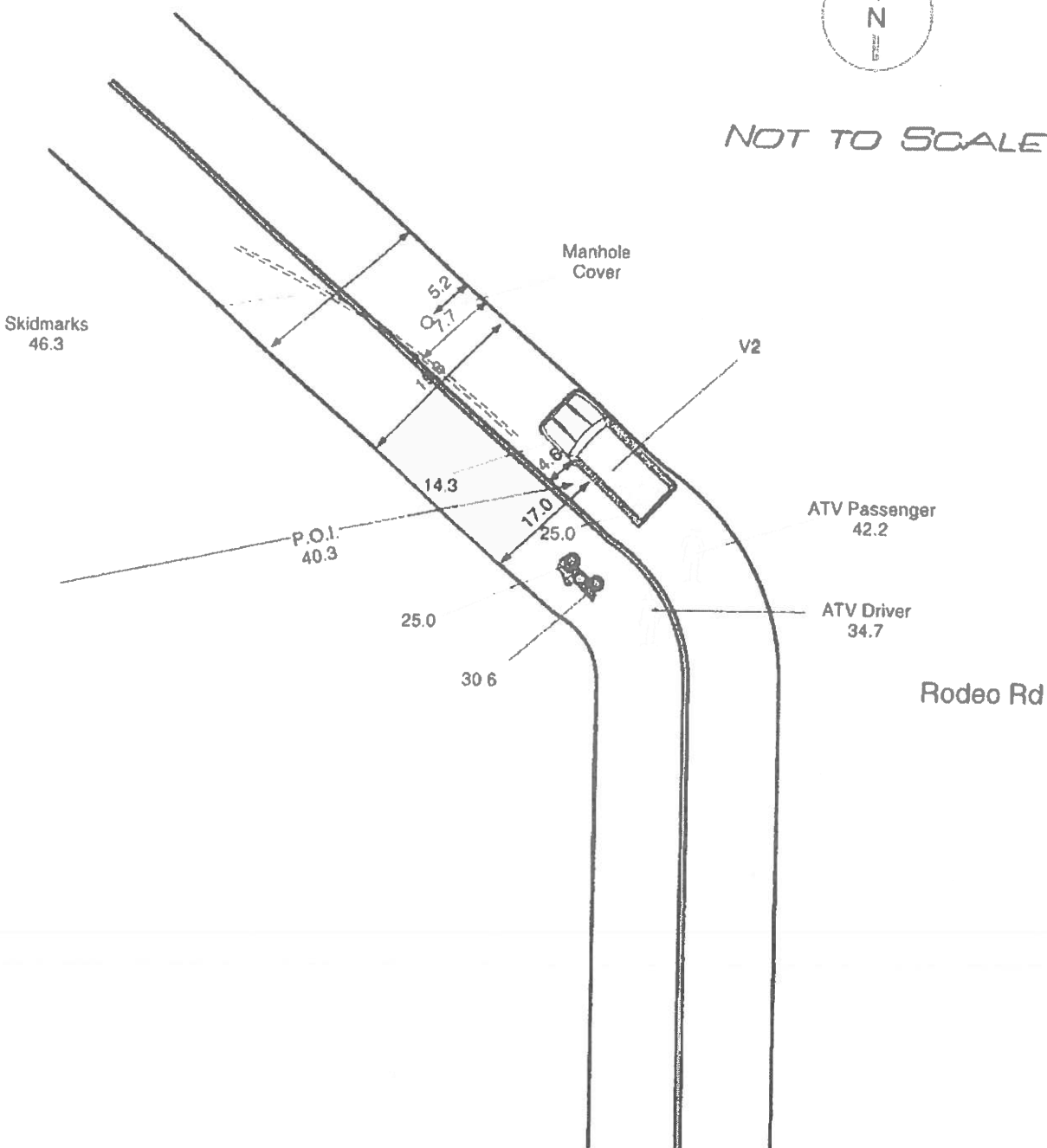

ARIZONA CRASH REPORT

REPORT ID

Agency Report Number

POLICE ONLY - FORWARD COPY TO ADOT TRAFFIC RECORDS SECTION, 064R 206 S 17TH AVE., PHOENIX, ARIZONA 85007-3233

YEAR MONTH DAY HOUR MIN SEC NOCC NO OFFICER ID NO

220003230

Total Number of Sheets 5

COMPLETE THE TRUCK/BUS SUPPLEMENT IF ANY (circle) AND ANY (diamond) ARE CHECKED

Total Units 1 Total Injuries 1 Total Fatalities 0 Estimated Total Damage Compared To \$2,000 Limit To \$2,000 Limit Over Under Fatal Injury Person Transported for Immediate Medical Care Tow Away of At Least One Vehicle from Scene?

Location On Highway/Road/Street Monte Vista Lane City Sedona County Yavapai

Light Condition Weather Conditions Global Position

Is this a Secondary Collision? Roadway Clear Time Incident Clear

Safety Devices (SD) Airbag (AB) Injury Severity (IS) Seating Position

Driver Information: Name, Address, Date of Birth, Vehicle Information: Color, Year, Make, Body Style, Plate Number

Insurance Company, Vehicle Removed to, Vehicle Removed by

PASSENGERS: Name, Address, City, State, Zip Code, Phone, Sex, D.O.B.

VEHICLE DAMAGED AREA(S) - (CIRCLE ALL THAT APPLY)

Property Damaged (Other than Vehicles) Owner Code

WITNESSES: Name, Address, City, State, Zip Code, Telephone Number, D.O.B.

CITATION: UNIT #, A.R.S. NO. OR CITY CODE

Photos Taken, Investigator Information: Name, Agency, Date Invest, Time Invest

ARIZONA CRASH REPORT REPORT ID

1	CONTINUED POLICE ONLY - FORWARD COPY TO ADOT TRAFFIC RECORDS SECTION, 064R 208 S. 17 TH AVE., PHOENIX, ARIZONA 85007-3233	YEAR	MONTH	DAY	HOUR	NCIC NO	OFFICER ID NO	Agency Report Number												
		2	2	0	3	1	6	1	6	5	9	0	3	1	0	0	0	0	8	8

Total Number of Sheets **5**

12 - ROAD SURFACE CONDITION UNIT # 1 <input type="checkbox"/> 01 DRY <input type="checkbox"/> 08 MUD/DIRT/GRAVEL/SAND <input type="checkbox"/> 02 WET <input type="checkbox"/> 09 OIL <input type="checkbox"/> 50 OTHER <input type="checkbox"/> 03 SNOW/SLEASH <input type="checkbox"/> 10 UNKNOWN <input type="checkbox"/> 04 ICE/FROST <input type="checkbox"/> 05 WATER (standing/moving)	19 - CONTRIBUTING CIRCUMSTANCES UP TO TWO CHOICES PER UNIT UNIT # 1 <input checked="" type="checkbox"/> 0 NO CONTRIBUTING CIRCUMSTANCE ENVIRONMENTAL 1. GLARE <input type="checkbox"/> 01 A SUNLIGHT <input type="checkbox"/> 03 ROAD SURFACE CONDITION <input type="checkbox"/> 02 B SHADOWS <input type="checkbox"/> 04 DEBRIS <input type="checkbox"/> 03 PASSENGER <input type="checkbox"/> 05 WORK ZONE <input type="checkbox"/> 04 OTHER ACTIVITY ELECTRONIC DEVICE <input type="checkbox"/> 06 OBSTRUCTION IN ROADWAY <input type="checkbox"/> 05 MANUALLY OPERATING AN ELECTRONIC DEVICE <input type="checkbox"/> 07 CHANGING ROAD WIDTH <input type="checkbox"/> 06 OTHER INSIDE THE VEHICLE (eating, drinking, etc.) <input type="checkbox"/> 08 NON-HIGHWAY WORK <input type="checkbox"/> 07 OUTSIDE THE VEHICLE (includes unspecified distractions) <input type="checkbox"/> 08 DISTRACTED, UNKNOWN REASON <input type="checkbox"/> 09 UNKNOWN IF DISTRACTED	22 - VIOLATIONS/BEHAVIOR CHECK ALL THAT APPLY UNIT # 1 <input type="checkbox"/> 01 NO IMPROPER ACTION <input type="checkbox"/> 02 SPEED TOO FAST FOR CONDITIONS <input type="checkbox"/> 03 EXCEEDED LAWFUL SPEED <input type="checkbox"/> 04 FOLLOWED TOO CLOSELY <input type="checkbox"/> 05 RAN STOP SIGN <input type="checkbox"/> 06 DISREGARDED TRAFFIC SIGNAL <input type="checkbox"/> 07 MADE IMPROPER TURN <input type="checkbox"/> 08 DROVE LEFT OF CENTER LINE <input type="checkbox"/> 09 WRONG WAY DRIVING <input type="checkbox"/> 10 CROSSED MEDIAN <input type="checkbox"/> 11 PASSED IN NO PASSING ZONE <input type="checkbox"/> 12 UNSAFE LANE CHANGE <input type="checkbox"/> 13 FAILED TO KEEP IN PROPER LANE <input type="checkbox"/> 14 DID NOT USE CROSSWALK <input type="checkbox"/> 15 FAILED TO YIELD RIGHT-OF-WAY <input type="checkbox"/> 16 AGGRESSIVE DRIVING <input type="checkbox"/> 17 OTHER Multiple Riders <input type="checkbox"/> 18 UNKNOWN
--	--	---

13 - ROAD GRADE UNIT # 1 <input type="checkbox"/> 01 LEVEL <input type="checkbox"/> 03 UPHILL <input type="checkbox"/> 02 DOWNHILL <input type="checkbox"/> 04 UNKNOWN	20 - DISTRACTED DRIVING BEHAVIOR UNIT # 1 <input type="checkbox"/> 00 NOT DISTRACTED/NOT APPLICABLE <input type="checkbox"/> 01 TALKING ON HANDS FREE DEVICE <input type="checkbox"/> 02 TALKING ON HAND HELD DEVICE <input type="checkbox"/> 03 PASSENGER <input type="checkbox"/> 04 OTHER ACTIVITY ELECTRONIC DEVICE <input type="checkbox"/> 05 MANUALLY OPERATING AN ELECTRONIC DEVICE <input type="checkbox"/> 06 OTHER INSIDE THE VEHICLE (eating, drinking, etc.) <input type="checkbox"/> 07 OUTSIDE THE VEHICLE (includes unspecified distractions) <input type="checkbox"/> 08 DISTRACTED, UNKNOWN REASON <input type="checkbox"/> 09 UNKNOWN IF DISTRACTED	23 - TRAFFIC UNIT MANEUVER/ACTION UNIT # 1 <input type="checkbox"/> 01 GOING STRAIGHT AHEAD <input type="checkbox"/> 02 SLOWING IN TRAFFICWAY <input type="checkbox"/> 03 STOPPED IN TRAFFICWAY <input type="checkbox"/> 04 MAKING LEFT TURN <input type="checkbox"/> 05 MAKING RIGHT TURN <input type="checkbox"/> 06 MAKING U-TURN <input type="checkbox"/> 07 OVERTAKING/PASSING <input type="checkbox"/> 08 CHANGING LANES <input type="checkbox"/> 09 NEGOTIATING A CURVE <input type="checkbox"/> 10 BACKING <input type="checkbox"/> 11 AVOIDING VEHICLE/OBJECT/PED/CYCLIST <input type="checkbox"/> 12 ENTERING PARKING POSITION <input type="checkbox"/> 13 LEAVING PARKING POSITION <input type="checkbox"/> 14 PROPERLY PARKED <input type="checkbox"/> 15 IMPROPERLY PARKED <input type="checkbox"/> 16 MOVING VEHICLE - NO DRIVER <input type="checkbox"/> 17 CROSSING ROAD <input type="checkbox"/> 18 WALKING WITH TRAFFIC <input type="checkbox"/> 19 WALKING AGAINST TRAFFIC <input type="checkbox"/> 20 STANDING <input type="checkbox"/> 21 LYING <input type="checkbox"/> 22 GETTING ON/OFF VEHICLE <input type="checkbox"/> 23 OTHER <input type="checkbox"/> 24 UNKNOWN
--	--	---

14 - RELATION TO JUNCTION <input type="checkbox"/> 00 NOT JUNCTION RELATED <input type="checkbox"/> 04 RAILWAY GRADE CROSSING <input type="checkbox"/> 01 INTERSECTION (within) <input type="checkbox"/> 05 DRIVEWAY or ALLEY ACCESS <input type="checkbox"/> 02 INTERSECTION-RELATED <input type="checkbox"/> 06 OTHER <input type="checkbox"/> 03 ENTRANCE/EXIT RAMP <input type="checkbox"/> 07 UNKNOWN	21 - CONDITION INFLUENCING Driver/Ped/Cyclist UP TO THREE CHOICES PER UNIT UNIT # 1 <input type="checkbox"/> 00 NO APPARENT INFLUENCE <input type="checkbox"/> 01 ILLNESS OR PHYSICAL IMPAIRMENT <input type="checkbox"/> 02 FELL ASLEEP/FATIGUED <input type="checkbox"/> 03 ALCOHOL <input type="checkbox"/> 04 MEDICATIONS <input type="checkbox"/> 05 MARIJUANA <input type="checkbox"/> 06 MED MARIJUANA CARD PRESENTED <input type="checkbox"/> 07 OTHER <input type="checkbox"/> 08 UNKNOWN CONDITION	24 - LOCATION OF PEDESTRIAN/CYCLIST UNIT # 1 <input type="checkbox"/> 01 AT INTERSECTION-W/ MARKED CROSSWALK <input type="checkbox"/> 02 AT INTERSECTION-UNMARKED/UNKNOWN IF MARKED CROSSWALK <input type="checkbox"/> 03 AT INTERSECTION-NOT IN CROSSWALK <input type="checkbox"/> 04 AT INTERSECTION-UNKNOWN LOCATION <input type="checkbox"/> 05 NOT AT INTERSECTION-IN MARKED CROSSWALK <input type="checkbox"/> 06 NOT AT INTERSECTION-ON ROADWAY, NOT IN MARKED CROSSWALK <input type="checkbox"/> 07 NOT AT INTERSECTION-ON ROADWAY, CROSSWALK AVAILABILITY UNKNOWN <input type="checkbox"/> 08 SCHOOL CROSSWALK <input type="checkbox"/> 09 PARKING LANE/ZONE
---	--	--

15 - TRAFFICWAY DESCRIPTION <input type="checkbox"/> 01 ONE WAY TRAFFICWAY <input type="checkbox"/> 02 TWO-WAY, NOT DIVIDED (no median present) <input type="checkbox"/> 03 TWO-WAY, (NOT DIVIDED) WITH A CONTINUOUS LEFT TURN LANE <input type="checkbox"/> 04 TWO-WAY, DIVIDED, UNPROTECTED MEDIAN <input type="checkbox"/> 05 TWO-WAY, DIVIDED, POSITIVE MEDIAN BARRIER <input type="checkbox"/> 06 UNKNOWN	16 - TRAFFIC CONTROL DEVICE UNIT # 1 <input type="checkbox"/> 00 NO CONTROLS <input type="checkbox"/> 07 PERSON (law enforcement, crossing guard, flagger etc.) <input type="checkbox"/> 01 SIGNAL <input type="checkbox"/> 08 TRAFFIC CIRCLE / ROUNDABOUT <input type="checkbox"/> 02 STOP SIGN <input type="checkbox"/> 09 PEDESTRIAN HYBRID BEACON/HAWK <input type="checkbox"/> 03 YIELD SIGN <input type="checkbox"/> 10 OTHER <input type="checkbox"/> 04 WARNING SIGN <input type="checkbox"/> 11 UNKNOWN <input type="checkbox"/> 05 RAILROAD CROSSING SIGN <input type="checkbox"/> 06 FLASHING TRAFFIC SIGNAL	25 - COLLISION WITH FIXED OBJECT 29 IMPACT ATTENUATOR/CRASH CUSHION/GUARDRAIL END 30 CONCRETE CURB 31 GUARDRAIL FACE 32 MEDIAN BARRIER 33 CABLE BARRIER 34 TREE BUSH, STUMP (standing) 35 TRAFFIC SIGN SUPPORT 36 TRAFFIC SIGNAL SUPPORT 37 UTILITY POLE/LIGHT SUPPORT 38 FENCE 39 OTHER FIXED OBJ 40 UNKNOWN
---	--	--

17 - MANNER OF CRASH IMPACT <input type="checkbox"/> 01 SINGLE VEHICLE <input type="checkbox"/> 06 SIDESWIPE, SAME DIRECTION <input type="checkbox"/> 02 ANGLE (front to side) <input type="checkbox"/> 07 SIDESWIPE, OPPOSITE DIRECTION <input type="checkbox"/> 03 LEFT TURN <input type="checkbox"/> 08 U-TURN <input type="checkbox"/> 04 REAR END (front-to-rear) <input type="checkbox"/> 09 OTHER <input type="checkbox"/> 05 HEAD-ON (front-to-front) <input type="checkbox"/> 10 UNKNOWN (other than left turn)	26 - ROADWAY ALIGNMENT UNIT # 1 <input type="checkbox"/> 01 STRAIGHT <input type="checkbox"/> 03 CURVE RIGHT <input type="checkbox"/> 02 CURVE LEFT <input type="checkbox"/> 04 UNKNOWN	27 - SEQUENCE OF EVENTS UP TO FOUR CRASH EVENTS FOR EACH UNIT IN THE ORDER OF OCCURRENCE NON-COLLISION 1 OVERTURN/ROLOVER 2 FIRE/EXPLOSION 3 CARGO/EQUIPMENT LOSS/SHIFT 4 FELL/JUMPED FROM VEHICLE 5 OTHER NON-COLLISION 6 EQUIPMENT FAILURE (brake brakes) 7 SEPARATION OF UNITS 8 RAN OFF ROAD RIGHT 9 RAN OFF ROAD LEFT 10 CROSS MEDIAN 11 CROSS CENTERLINE 12 DOWNHILL RUNAWAY
--	---	--

18 - DIRECTION OF UNIT TRAVEL (Compass) BEFORE 1ST CRASH EVENT UNIT # 1 <input type="checkbox"/> 01 NORTH <input type="checkbox"/> 06 NORTHEAST <input type="checkbox"/> 02 SOUTH <input type="checkbox"/> 07 SOUTHWEST <input type="checkbox"/> 03 EAST <input type="checkbox"/> 08 SOUTHEAST <input type="checkbox"/> 04 WEST <input type="checkbox"/> 09 UNKNOWN <input type="checkbox"/> 05 NORTHWEST	28 - LANE Please enter unit's number and lane of travel before first crash event <table border="1" style="width: 100%; border-collapse: collapse;"> <tr> <th style="width: 50%;">UNIT 1</th> <th style="width: 50%;">UNIT NA</th> </tr> <tr> <td style="text-align: center;">1</td> <td style="text-align: center;">1</td> </tr> </table>	UNIT 1	UNIT NA	1	1	28 - COLLISION WITH PERSON, MOTOR VEHICLE, OR NON-FIXED OBJECT 16 MOTOR VEHICLE IN TRANSPORT 17 PEDESTRIAN 18 PEDALCYCLE 19 TRAIN 20 LIGHT RAILWAY/RAILCAR VEHICLE 21 ANIMAL 22 PARKED MOTOR VEHICLE 23 STRUCK BY FALLING, SHIFTING CARGO OR ANYTHING SET IN MOTION BY ANOTHER VEHICLE 24 OTHER NON-FIXED OBJ
UNIT 1	UNIT NA					
1	1					

NOTE: FOR PARKED OR STOPPED VEHICLES, INDICATE THE DIRECTION THE VEHICLE WAS FACING AT THE TIME OF THE CRASH	29 - COLLISION WITH FIXED OBJECT 29 IMPACT ATTENUATOR/CRASH CUSHION/GUARDRAIL END 30 CONCRETE CURB 31 GUARDRAIL FACE 32 MEDIAN BARRIER 33 CABLE BARRIER 34 TREE BUSH, STUMP (standing) 35 TRAFFIC SIGN SUPPORT 36 TRAFFIC SIGNAL SUPPORT 37 UTILITY POLE/LIGHT SUPPORT 38 FENCE 39 OTHER FIXED OBJ 40 UNKNOWN	29 - COLLISION WITH FIXED OBJECT 29 IMPACT ATTENUATOR/CRASH CUSHION/GUARDRAIL END 30 CONCRETE CURB 31 GUARDRAIL FACE 32 MEDIAN BARRIER 33 CABLE BARRIER 34 TREE BUSH, STUMP (standing) 35 TRAFFIC SIGN SUPPORT 36 TRAFFIC SIGNAL SUPPORT 37 UTILITY POLE/LIGHT SUPPORT 38 FENCE 39 OTHER FIXED OBJ 40 UNKNOWN
--	--	--

29 - COLLISION WITH FIXED OBJECT 29 IMPACT ATTENUATOR/CRASH CUSHION/GUARDRAIL END 30 CONCRETE CURB 31 GUARDRAIL FACE 32 MEDIAN BARRIER 33 CABLE BARRIER 34 TREE BUSH, STUMP (standing) 35 TRAFFIC SIGN SUPPORT 36 TRAFFIC SIGNAL SUPPORT 37 UTILITY POLE/LIGHT SUPPORT 38 FENCE 39 OTHER FIXED OBJ 40 UNKNOWN	30 - SEQUENCE OF EVENTS PER TRAFFIC UNIT <table border="1" style="width: 100%; border-collapse: collapse;"> <thead> <tr> <th>Event</th> <th>Unit 1</th> <th>Unit NA</th> </tr> </thead> <tbody> <tr> <td>FIRST EVENT</td> <td style="text-align: center;">16</td> <td></td> </tr> <tr> <td>SECOND EVENT</td> <td style="text-align: center;">11</td> <td></td> </tr> <tr> <td>THIRD EVENT</td> <td style="text-align: center;">1</td> <td></td> </tr> <tr> <td>FOURTH EVENT</td> <td></td> <td></td> </tr> </tbody> </table>	Event	Unit 1	Unit NA	FIRST EVENT	16		SECOND EVENT	11		THIRD EVENT	1		FOURTH EVENT			31 - FIRST HARMFUL EVENT OF THE CRASH 16 MOTOR VEHICLE IN TRANSPORT 17 PEDESTRIAN 18 PEDALCYCLE 19 TRAIN 20 LIGHT RAILWAY/RAILCAR VEHICLE 21 ANIMAL 22 PARKED MOTOR VEHICLE 23 STRUCK BY FALLING, SHIFTING CARGO OR ANYTHING SET IN MOTION BY ANOTHER VEHICLE 24 OTHER NON-FIXED OBJ
Event	Unit 1	Unit NA															
FIRST EVENT	16																
SECOND EVENT	11																
THIRD EVENT	1																
FOURTH EVENT																	

30 - SEQUENCE OF EVENTS PER TRAFFIC UNIT <table border="1" style="width: 100%; border-collapse: collapse;"> <thead> <tr> <th>Event</th> <th>Unit 1</th> <th>Unit NA</th> </tr> </thead> <tbody> <tr> <td>FIRST EVENT</td> <td style="text-align: center;">16</td> <td></td> </tr> <tr> <td>SECOND EVENT</td> <td style="text-align: center;">11</td> <td></td> </tr> <tr> <td>THIRD EVENT</td> <td style="text-align: center;">1</td> <td></td> </tr> <tr> <td>FOURTH EVENT</td> <td></td> <td></td> </tr> </tbody> </table>	Event	Unit 1	Unit NA	FIRST EVENT	16		SECOND EVENT	11		THIRD EVENT	1		FOURTH EVENT			31 - FIRST HARMFUL EVENT OF THE CRASH 16 MOTOR VEHICLE IN TRANSPORT 17 PEDESTRIAN 18 PEDALCYCLE 19 TRAIN 20 LIGHT RAILWAY/RAILCAR VEHICLE 21 ANIMAL 22 PARKED MOTOR VEHICLE 23 STRUCK BY FALLING, SHIFTING CARGO OR ANYTHING SET IN MOTION BY ANOTHER VEHICLE 24 OTHER NON-FIXED OBJ	32 - FIRST HARMFUL EVENT OF THE CRASH 16 MOTOR VEHICLE IN TRANSPORT 17 PEDESTRIAN 18 PEDALCYCLE 19 TRAIN 20 LIGHT RAILWAY/RAILCAR VEHICLE 21 ANIMAL 22 PARKED MOTOR VEHICLE 23 STRUCK BY FALLING, SHIFTING CARGO OR ANYTHING SET IN MOTION BY ANOTHER VEHICLE 24 OTHER NON-FIXED OBJ
Event	Unit 1	Unit NA															
FIRST EVENT	16																
SECOND EVENT	11																
THIRD EVENT	1																
FOURTH EVENT																	

31 - FIRST HARMFUL EVENT OF THE CRASH 16 MOTOR VEHICLE IN TRANSPORT 17 PEDESTRIAN 18 PEDALCYCLE 19 TRAIN 20 LIGHT RAILWAY/RAILCAR VEHICLE 21 ANIMAL 22 PARKED MOTOR VEHICLE 23 STRUCK BY FALLING, SHIFTING CARGO OR ANYTHING SET IN MOTION BY ANOTHER VEHICLE 24 OTHER NON-FIXED OBJ	32 - FIRST HARMFUL EVENT OF THE CRASH 16 MOTOR VEHICLE IN TRANSPORT 17 PEDESTRIAN 18 PEDALCYCLE 19 TRAIN 20 LIGHT RAILWAY/RAILCAR VEHICLE 21 ANIMAL 22 PARKED MOTOR VEHICLE 23 STRUCK BY FALLING, SHIFTING CARGO OR ANYTHING SET IN MOTION BY ANOTHER VEHICLE 24 OTHER NON-FIXED OBJ	33 - FIRST HARMFUL EVENT OF THE CRASH 16 MOTOR VEHICLE IN TRANSPORT 17 PEDESTRIAN 18 PEDALCYCLE 19 TRAIN 20 LIGHT RAILWAY/RAILCAR VEHICLE 21 ANIMAL 22 PARKED MOTOR VEHICLE 23 STRUCK BY FALLING, SHIFTING CARGO OR ANYTHING SET IN MOTION BY ANOTHER VEHICLE 24 OTHER NON-FIXED OBJ
--	--	--

32 - FIRST HARMFUL EVENT OF THE CRASH 16 MOTOR VEHICLE IN TRANSPORT 17 PEDESTRIAN 18 PEDALCYCLE 19 TRAIN 20 LIGHT RAILWAY/RAILCAR VEHICLE 21 ANIMAL 22 PARKED MOTOR VEHICLE 23 STRUCK BY FALLING, SHIFTING CARGO OR ANYTHING SET IN MOTION BY ANOTHER VEHICLE 24 OTHER NON-FIXED OBJ	33 - FIRST HARMFUL EVENT OF THE CRASH 16 MOTOR VEHICLE IN TRANSPORT 17 PEDESTRIAN 18 PEDALCYCLE 19 TRAIN 20 LIGHT RAILWAY/RAILCAR VEHICLE 21 ANIMAL 22 PARKED MOTOR VEHICLE 23 STRUCK BY FALLING, SHIFTING CARGO OR ANYTHING SET IN MOTION BY ANOTHER VEHICLE 24 OTHER NON-FIXED OBJ	34 - FIRST HARMFUL EVENT OF THE CRASH 16 MOTOR VEHICLE IN TRANSPORT 17 PEDESTRIAN 18 PEDALCYCLE 19 TRAIN 20 LIGHT RAILWAY/RAILCAR VEHICLE 21 ANIMAL 22 PARKED MOTOR VEHICLE 23 STRUCK BY FALLING, SHIFTING CARGO OR ANYTHING SET IN MOTION BY ANOTHER VEHICLE 24 OTHER NON-FIXED OBJ
--	--	--

33 - FIRST HARMFUL EVENT OF THE CRASH 16 MOTOR VEHICLE IN TRANSPORT 17 PEDESTRIAN 18 PEDALCYCLE 19 TRAIN 20 LIGHT RAILWAY/RAILCAR VEHICLE 21 ANIMAL 22 PARKED MOTOR VEHICLE 23 STRUCK BY FALLING, SHIFTING CARGO OR ANYTHING SET IN MOTION BY ANOTHER VEHICLE 24 OTHER NON-FIXED OBJ	34 - FIRST HARMFUL EVENT OF THE CRASH 16 MOTOR VEHICLE IN TRANSPORT 17 PEDESTRIAN 18 PEDALCYCLE 19 TRAIN 20 LIGHT RAILWAY/RAILCAR VEHICLE 21 ANIMAL 22 PARKED MOTOR VEHICLE 23 STRUCK BY FALLING, SHIFTING CARGO OR ANYTHING SET IN MOTION BY ANOTHER VEHICLE 24 OTHER NON-FIXED OBJ	35 - FIRST HARMFUL EVENT OF THE CRASH 16 MOTOR VEHICLE IN TRANSPORT 17 PEDESTRIAN 18 PEDALCYCLE 19 TRAIN 20 LIGHT RAILWAY/RAILCAR VEHICLE 21 ANIMAL 22 PARKED MOTOR VEHICLE 23 STRUCK BY FALLING, SHIFTING CARGO OR ANYTHING SET IN MOTION BY ANOTHER VEHICLE 24 OTHER NON-FIXED OBJ
--	--	--

34 - FIRST HARMFUL EVENT OF THE CRASH 16 MOTOR VEHICLE IN TRANSPORT 17 PEDESTRIAN 18 PEDALCYCLE 19 TRAIN 20 LIGHT RAILWAY/RAILCAR VEHICLE 21 ANIMAL 22 PARKED MOTOR VEHICLE 23 STRUCK BY FALLING, SHIFTING CARGO OR ANYTHING SET IN MOTION BY ANOTHER VEHICLE 24 OTHER NON-FIXED OBJ	35 - FIRST HARMFUL EVENT OF THE CRASH 16 MOTOR VEHICLE IN TRANSPORT 17 PEDESTRIAN 18 PEDALCYCLE 19 TRAIN 20 LIGHT RAILWAY/RAILCAR VEHICLE 21 ANIMAL 22 PARKED MOTOR VEHICLE 23 STRUCK BY FALLING, SHIFTING CARGO OR ANYTHING SET IN MOTION BY ANOTHER VEHICLE 24 OTHER NON-FIXED OBJ	36 - FIRST HARMFUL EVENT OF THE CRASH 16 MOTOR VEHICLE IN TRANSPORT 17 PEDESTRIAN 18 PEDALCYCLE 19 TRAIN 20 LIGHT RAILWAY/RAILCAR VEHICLE 21 ANIMAL 22 PARKED MOTOR VEHICLE 23 STRUCK BY FALLING, SHIFTING CARGO OR ANYTHING SET IN MOTION BY ANOTHER VEHICLE 24 OTHER NON-FIXED OBJ
--	--	--

35 - FIRST HARMFUL EVENT OF THE CRASH 16 MOTOR VEHICLE IN TRANSPORT 17 PEDESTRIAN 18 PEDALCYCLE 19 TRAIN 20 LIGHT RAILWAY/RAILCAR VEHICLE 21 ANIMAL 22 PARKED MOTOR VEHICLE 23 STRUCK BY FALLING, SHIFTING CARGO OR ANYTHING SET IN MOTION BY ANOTHER VEHICLE 24 OTHER NON-FIXED OBJ	36 - FIRST HARMFUL EVENT OF THE CRASH 16 MOTOR VEHICLE IN TRANSPORT 17 PEDESTRIAN 18 PEDALCYCLE 19 TRAIN 20 LIGHT RAILWAY/RAILCAR VEHICLE 21 ANIMAL 22 PARKED MOTOR VEHICLE 23 STRUCK BY FALLING, SHIFTING CARGO OR ANYTHING SET IN MOTION BY ANOTHER VEHICLE 24 OTHER NON-FIXED OBJ	37 - FIRST HARMFUL EVENT OF THE CRASH 16 MOTOR VEHICLE IN TRANSPORT 17 PEDESTRIAN 18 PEDALCYCLE 19 TRAIN 20 LIGHT RAILWAY/RAILCAR VEHICLE 21 ANIMAL 22 PARKED MOTOR VEHICLE 23 STRUCK BY FALLING, SHIFTING CARGO OR ANYTHING SET IN MOTION BY ANOTHER VEHICLE 24 OTHER NON-FIXED OBJ
--	--	--

ARIZONA CRASH REPORT		REPORT ID										Agency Report Number							
1	CONTINUED POLICE ONLY--FORWARD COPY TO ADOT TRAFFIC RECORDS SECTION, 054R 206 S. 17TH AVE PHOENIX ARIZONA 85007-3233	YEAR	MONTH	DAY	HOUR				NCIC NO				OFFICER ID NO				220003230		
		2	2	0	3	1	6	1	6	5	9	0	3	1	0	0		0	0
28	CRASH DIAGRAM															29			
																INDICATE NORTH ↓			

MEASUREMENTS ARE APPROXIMATE AND NOT TO SCALE
 MEASUREMENTS ARE SCALED (SCALE = _____)

30	NARRATIVE	Describe what happened
<p>Vehicle 1 is a small 4 wheel ATV. Driver of Vehicle 1 have two passengers sitting left and right of him. Vehicle one was south bound on Monte Vista Lane at an estimated speed of 25-30mph. Witnesses stated that the vehicle was out of control after narrowly missing a tree on the west side of the Monte Vista cul-de-sac. The two passengers were able to jump off the vehicle before Vehicle 1 rolled over on it's left side pinning the rider underneath.</p> <p>As I arrived on scene the passengers stated they had already lifted the ATV off the Driver who was laying on his back screaming loudly in pain for what appeared to be an injury to his right leg. The Driver of Vehicle 1 was transported to Verde Valley Medical Center (VVMC) for his injuries.</p> <p>One of the other riders suffered a road abrasion to his left forearm, he was medically treated on scene for his injuries.</p>		

Case Number: 220003230

Date: 03/17/22

Location: 115 Monte Vista Lane

Narrative:

A. Gas Meters used for permanent point of refernce.

Case Number: 220003230 Date: 03/17/22

Location: 115 Monte Vista Lane

Description:



NOT TO SCALE

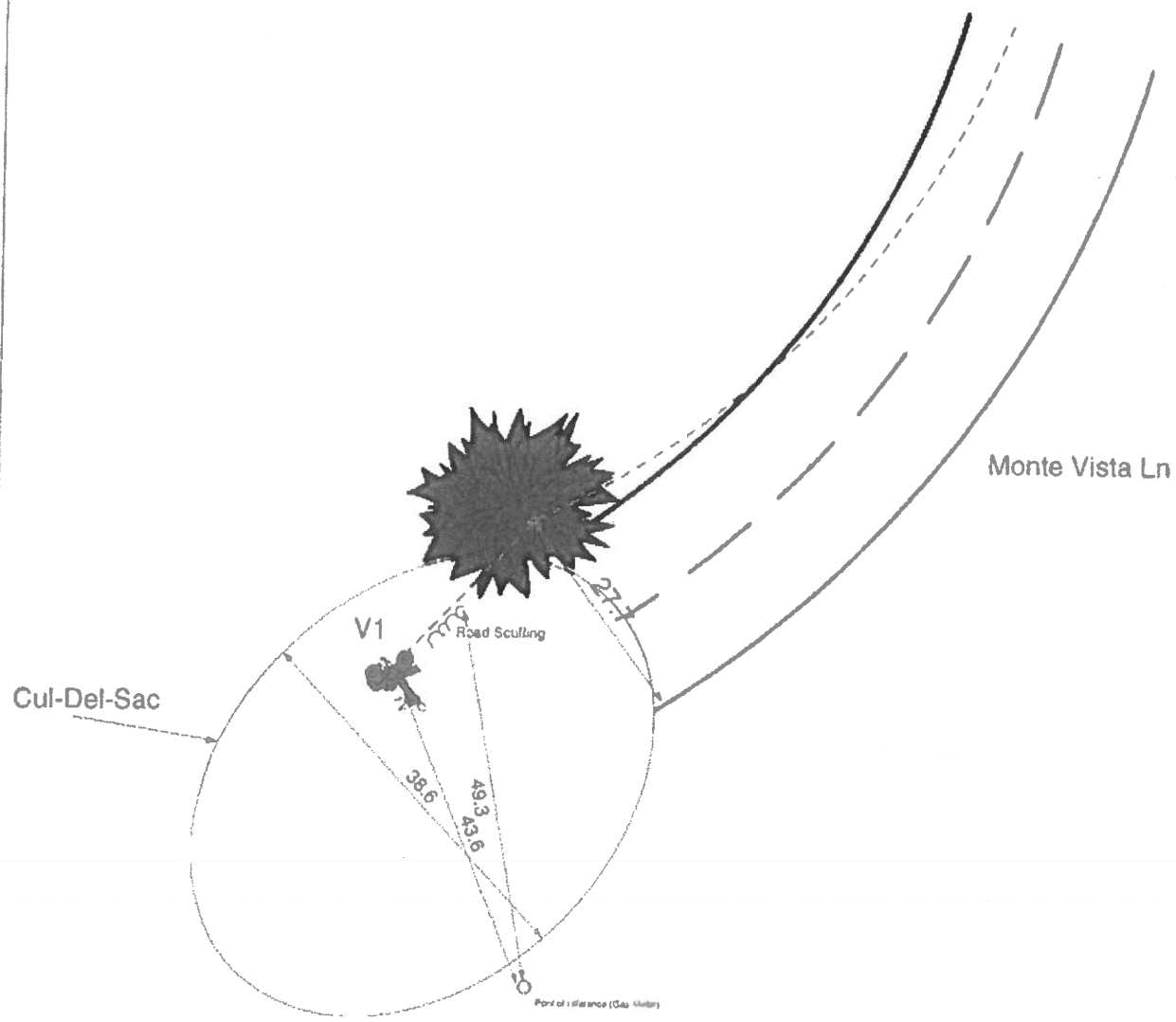



June 5, 2023

The Honorable Scott Jablow
Mayor
Sedona, Arizona
102 Roadrunner Drive
Sedona, AZ 86336-3710

Re: ROHVA opposes on-road ROV use

Dear Mayor Jablow:

Thank you for reaching out to discuss the Recreational Off-Highway Vehicle Association's (ROHVA)¹ opposition to the use of recreational off-highway vehicles (ROVs – sometimes referred to as side-by-sides or UTVs) on public roads.

ROHVA's primary goal is to promote safe and responsible use of ROVs. ROHVA opposes allowing ROVs on roads that are not part of a designated trail system because:

- ROV manufacturers design, test, and sell ROVs for *off-highway use only*.
- Unlike cars and trucks, ROVs do not meet Federal motor vehicle safety standards.

Allowing ROVs on roads falsely signals that this practice is safe. It is not. ROV manufacturers, along with the National Highway Traffic Safety Administration, stress that ROVs are not designed for use on public roadways. **The vehicles do not handle properly on paved roads. They also lack safety equipment required to protect occupants in the event of a collision. On-road ROV operators and passengers face increased risks of losing vehicle control. Collisions with cars and trucks also pose an increased risk of injury. These risks remain even when owners or aftermarket providers install different tires or modify ROV equipment in other ways.**

ROHVA urges states and localities to prohibit ROV use on public roads and strengthen law enforcement efforts to eliminate this dangerous practice. States and localities could prevent a substantial number of ROV-related injuries if laws kept ROVs off public roads, which ROHVA proposes in its model legislation.²

¹ ROHVA is a national, not-for-profit trade association formed to promote the safe and responsible use of recreational off-highway vehicles (ROVs) manufactured or distributed in North America. ROHVA is also accredited by the American National Standards Institute (ANSI) to serve as the Standards Developing Organization for ROVs. An ROV is a motorized off-highway vehicle that is compliant with the ANSI/ROHVA 1 standard. More information on the standard can be found at <https://rohva.org/ansi-standard/>. ROVs are designed to travel on four or more tires, intended by the manufacturer for use by one or more persons and having the following characteristics: a steering wheel for steering control; a Roll Over Protective Structure complying with ANSI/ROHVA-1; an Occupant Retention System complying with ANSI/ROHVA-1; non-straddle seating; maximum speed capability greater than 30 mph; less than 80 inches in overall width, exclusive of accessories; and engine displacement of less than 1,000cc. Current models are designed with seats for a driver and one or more passengers.

² <https://rohva.org/model-law/>

Thank you for your consideration. Should you have any questions, please contact me at 703-582-1202.

Sincerely:

A handwritten signature in black ink, appearing to read "Duane Taylor". The signature is fluid and cursive, with a large initial "D" and a long horizontal stroke at the end.

Duane Taylor
Director of Safe and Responsible Use Programs



**CITY COUNCIL
AGENDA BILL**

**AB 2986
August 22, 2023
Regular Business**

Agenda Item: 8d
Proposed Action & Subject: Discussion/possible action regarding an Ordinance amending the Sedona City Code Title 13 (Public Services and Utilities) Division II (Storm Water) by amending Chapter 13.50 (Storm Water Discharge). *(First Public Meeting)*

Department	Public Works/Engineering/City Attorney
Time to Present	5 minutes
Total Time for Item	15 minutes
Other Council Meetings	None
Exhibits	A. Draft Ordinance

City Attorney Approval	Reviewed 8/15/23 KWC	Expenditure Required	\$ 0
City Manager's Recommendation	Adopt an ordinance amending Sedona City Code Title 13 Public Services and Utilities) Chapter 13.50 (Storm Water Discharge).	Amount Budgeted	\$ 0
		Account No. (Description)	N/A
		Finance Approval	<input checked="" type="checkbox"/>

SUMMARY STATEMENT

Background:

Sedona City Code Chapter 13.50 provides guidance for review and administration of illicit and permitted stormwater discharge. Although stormwater runoff is a permitted discharge, it does not specify a property owner's responsibility to maintain the historic manner of discharge or flows. There has been an increase in complaints to the City by residents who have been negatively impacted by unpermitted changes to their neighbors' properties. Although damages or issues resulting from private lot-to-lot drainage is generally a civil matter in which the City does not generally provide enforcement, this code provides clearer guidance to all involved including reviewers and residents.

The addition of Section 13.50.070 (Lot Drainage) more clearly defines the prohibition to alter surface runoff and lot-to-lot drainage by erecting fences, walls, berms, and other modifications or new development that would change the manner by which surface water enters and exits real property.

There is also an addition to Section 13.50.100 (Plan review, inspections, access, and reports), Item G., which is a liability waiver absolving the City of Sedona from insufficient design or construction.

This is the first public meeting. Unless an emergency requires otherwise, this ordinance will be brought back to Council at a subsequent public meeting for adoption.

Climate Action Plan/Sustainability Consistent: Yes - No - Not Applicable

Board/Commission Recommendation: Applicable - Not Applicable

Alternative(s): None

MOTION

(First Public Meeting)

I move to: adopt Ordinance No. 2023-__ an ordinance of the Mayor and Council of the City of Sedona, Arizona adopting amendments to the Sedona City Code Title 13 Public Services and Utilities) by amending Chapter 13.50 (Storm Water Discharge).

ORDINANCE NO. 2023-____

AN ORDINANCE OF THE CITY OF SEDONA, ARIZONA, ADOPTING AN AMENDMENT TO THE CITY CODE TITLE 13 (PUBLIC SERVICES AND UTILITIES) BY AMENDING CHAPTER 13.50 (STORM WATER DISCHARGE); PROVIDING FOR LOT DRAINAGE AND A LIABILITY WAIVER; AND ESTABLISHING AN EFFECTIVE DATE.

WHEREAS the City seeks to provide for the general health, safety and welfare of the public;

WHEREAS the City has become aware that some property owners have altered their properties to affect storm water and non-storm water runoff;

WHEREAS such alternations sometimes negatively affect adjacent properties and the need for safe and efficient runoff drainage;

WHEREAS the City needs to ensure proper storm water and non-storm water runoff;

WHEREAS, the City deems it necessary to adopt certain Amendments to the City Code and to protect the health, safety, and welfare of the City residents and the public.

BE IT ORDAINED BY THE MAYOR AND CITY COUNCIL OF THE CITY OF SEDONA, ARIZONA, as follows:

Section 1. Amendment of Sedona City Code Chapter 13.50 (STORM WATER DISCHARGE)

Title 13 (Public Utilities and Services) of the City Code of the City of Sedona is hereby amended by amending Section 13.50 (Storm Water Discharge) as follows:

**Chapter 13.50
STORM WATER DISCHARGE**

Sections:

- 13.50.010 Finding of fact.**
- 13.50.020 Purpose and intent.**
- 13.50.030 Definitions.**
- 13.50.040 Applicability.**
- 13.50.050 Responsibility for administration.**
- 13.50.060 Severability.**

13.50.070	080	Lot Drainage.
13.50.070	080	Discharge prohibitions.
13.50.080	090	Permitted non-storm water discharges.
13.50.090	100	Plan review, inspections, access, and reports.
13.50.100	110	Suspension of MS4 access.
13.50.110	120	Industrial or construction activity discharges.
13.50.120	130	Suspension due to the detection of illicit discharge.
13.50.130	140	Watercourse protection.
13.50.140	150	Notification of spills.
13.50.150	160	Enforcement.

13.50.010 Finding of fact.

Illicit discharges occur due to illicit connections to the municipal separate storm sewer system (“MS4”) from residential, business, industrial or commercial establishments. As a result of illicit connections, contaminated storm water, wastes or wastewater enters into storm drains or directly into local waters without receiving treatment from a wastewater treatment plant. Illicit connections may be intentional or may be unknown to the property or business owner. Illicit discharges to the city storm water system can cause excessive discharges of pollutants to surface waters and groundwater. These discharges can negatively impact public health, welfare, and the environment by transporting and depositing pollutants. [Code 2006 § 14-1-1. Ord. 2007-17, 11-13-2007; Ord. 2014-06 § 1, 5-27-2014; Res. 2014-10 Exh. A, 5-27-2014].

13.50.020 Purpose and intent.

A. The purposes of this chapter ~~is~~ are:

13.50.021 To provide for health, safety, and general welfare within the city through the regulation of non-storm water discharges to the MS4 to the maximum extent practicable (“MEP”) as required by federal and state law. To this end this chapter requires that unless expressly authorized or exempted by this chapter, no person shall cause, participate in, or allow the discharge to a public right-of-way or public storm drain system of any substance that is not composed entirely of storm water. To further this

end, this chapter establishes authority to conduct and require inspection, monitoring, reporting, and enforcement activities to address the prevention, identification, and remediation of illicit discharges to the MS4.

[13.50.022 To provide for health, safety, and general welfare within the city through the regulation of stormwater runoff and lot drainage.](#)

B. It is the intent of this chapter to comply with AZPDES regulations for storm water discharges, to be consistent with the storm water quality provisions of the Federal Clean Water Act ([33](#) U.S.C. Section [1342](#)), and to enable the city to comply with all applicable storm water quality provisions of federal, state, and local laws and regulations to ensure the future health, safety, and general welfare within the city, as well as the protection and preservation of the local environment.

C. It is the intent of this chapter that the standards promulgated by this chapter are minimum standards; therefore, it is not intended or implied that compliance with the provisions of this chapter by any person will ensure that there will be no contamination, pollution, or unauthorized discharge of pollutants. [Code 2006 § 14-1-2. Ord. 2007-17, 11-13-2007; Ord. 2014-06 § 1, 5-27-2014; Res. 2014-10 Exh. A, 5-27-2014].

13.50.030 Definitions.

Unless the context specifically indicates otherwise, the meaning of words and terms used in this chapter shall be as set forth below:

“Arizona Department of Environmental Quality” or “ADEQ” means the Arizona state agency established pursuant to A.R.S. Section [49-102](#).

“Arizona Pollutant Discharge Elimination System (AZPDES)” means the program established by the state of Arizona by provisions in A.R.S. Title [49](#), Chapter 2, Article 3.1 to control the discharge of pollutants to waters in Arizona.

“AZPDES general permit” means a general permit issued by the ADEQ under authority delegated pursuant to [33](#) U.S.C. [1342\(b\)](#).

“Best management practices (BMPs)” means schedules of activities, prohibitions of practices, maintenance procedures, and other management practices to prevent or

reduce the discharge of pollutants to the MS4. BMPs also include treatment requirements, operating procedures, design requirements, and practices to control runoff, spillage, leaks, waste disposal, or pollution of storm drainage flows.

“City” means the city of Sedona, Arizona.

“Combined sewer” means an enclosed sewer system that conveys both sanitary sewage and storm water flows.

“Construction general permit” means a permit issued by the permitting authority that allows discharges to storm water from construction activities as defined in [40 C.F.R. Section 122.26](#).

“Construction site operator” means the primary operator of a construction site within the corporate limits of the city.

“CWA” means the Clean Water Act or the Federal Pollution Control Act, [22 U.S.C. Section 1251](#) et seq.

“Designee” means a person designated for a specific purpose by the city engineer.

“Discharge” means any spilling, leaking, pumping, pouring, emitting, emptying, injecting, placing, releasing, leaching, dumping, or disposing into or on any land in a manner that may cause pollution, when used without qualification.

“EPA” means the United States Environmental Protection Agency.

“Erosion” means the wearing away of land due to the actions of water, other liquid, and/or wind.

“Facility” means any land, building, installation, structure, equipment, device, conveyance, area, source, activity or practice from which there is, or with reasonable probability may be, a discharge.

“Illicit connection” means any manmade conveyance connecting an illicit discharge directly to an MS4.

“Illicit discharge” means any discharge to the MS4 that is not composed entirely of storm water, except for discharges allowed under the AZPDES Permit No. AZG2002-002.

“Maximum extent practicable (MEP)” means the technology based discharge standard for municipal separate storm sewer systems to reduce pollutants in storm water discharges. A discussion of MEP as it applies to small MS4s is found at [40 CFR 122.34](#). CWA Section 402(p)(3)(B)(iii) requires that a municipal permit shall require controls to reduce the discharge of pollutants to the maximum extent practicable, including best management practices, control techniques and system design, and engineering methods, and other provisions that the state determines appropriate for the control of such pollutants.

“Municipal separate storm sewer system” or “MS4” means a publicly owned conveyance or system of conveyances designed or used for collecting or conveying storm water which is not a combined sewer and which is not part of a publicly owned treatment works.

“Municipal storm water permit” means the AZPDES general permit Arizona Pollutant Discharge Elimination System (AZPDES) storm water permit for discharge from small municipal separate storm sewer systems (MS4s) to waters of the United States. This permit is issued by the Arizona Department of Environmental Quality (ADEQ) under authority delegated pursuant to [33 U.S.C. Section 1342\(b\)](#).

“National Pollutant Discharge Elimination System (NPDES)” means a permit issued by EPA (or by a state under authority delegated pursuant to [33 U.S.C. Section 1342\(b\)](#)).

“Non-storm water discharges” means a discharge not consisting entirely of storm water.

“Notice of intent” or “NOI” means that document submitted to the permitting authority in order to obtain coverage under a general permit.

“Permitting authority” means the NPDES-authorized state agency or EPA regional office that administers the NPDES storm water permit program.

“Person” means an individual, employee, officer, managing body, trust, firm, joint stock company, consortium, public or private corporation, including a government corporation, partnership, association or state, a political subdivision of this state, a commission, the United States government or any federal facility, interstate body or other entity.

“Pollutant” means anything that causes or contributes to pollution. Pollutants may include, but are not limited to: contaminants, toxic wastes, chemicals, petroleum products, biological materials, wrecked or discarded equipment, rocks, sand, paints,

varnishes and solvents, oil and other automotive fluids, nonhazardous liquid and solid wastes and yard wastes, refuse, rubbish, garbage, litter, or other discarded or abandoned objects, floatables, pesticides, herbicides, and fertilizers, hazardous substances and wastes, heat, sewage, fecal coliform and pathogens, dissolved and particulate metals, animal wastes, wastes and residues that result from constructing a building or structure, noxious or offensive matter of any kind, or any other liquid, solid, gaseous, or hazardous substance.

“Pollution” means the alteration of the physical, thermal, chemical, or biological quality of, or the contamination of, any water of the state or waters of the United States, that renders the water harmful, detrimental, or injurious to humans, animal life, vegetation, or property, or to the public health, safety, or welfare, or impairs the usefulness or the public enjoyment of the water for any lawful or reasonable purpose.

“Public storm drain system” means all or any part of the publicly owned and maintained roads, streets, catch basins, curbs, gutters, ditches, manmade channels, storm drains, and dry wells located within public easements, right-of-way, parks, common areas, retention areas, or other publicly owned or maintained real property designed or used for collecting, holding, treating, or conveying storm water.

“Publicly owned treatment works (POTW)” means any device or system used in the treatment (including recycling and reclamation) of municipal sewage or industrial wastes of a liquid nature that is owned by a state or municipality. This definition includes sewers, pipes, or other conveyances only if they convey wastewater to a POTW providing treatment.

“Receiving waters” means a river, ocean, stream, or other watercourse into which wastewater, storm water or treated effluent is discharged.

“Storm water” means any surface flow, runoff, or drainage consisting entirely of water from any form of natural precipitation, and resulting from such precipitation and which is being managed in accordance with BMPs appropriate to the facility, pollutant, and quantity of water. “Appropriate to the facility” shall mean consideration shall be given to the size, location, zoning, and use.

“Storm water management plan” means a document which describes the best management practices and activities to be implemented by the city to identify sources of pollution or contamination at a site and the actions to eliminate or reduce pollutant

discharges to storm water, storm water drainage systems, and/or receiving waters to the maximum extent practicable. This document may also be designated “storm water quality management plan.”

“Storm water pollution prevention plan (SWPPP)” means a document which describes the best management practices, including but not limited to processes, devices, and activities, to be implemented by a person or business to identify sources, potential or actual, of pollution or contamination at a site and the action to eliminate or reduce pollutant discharges to storm water, MS4, and/or receiving waters to the maximum extent practicable (MEP).

“Wastewater” means any water or other liquid, other than uncontaminated storm water, discharged from a facility.

“Watercourse” means any body of water, including, but not limited to, lakes, ponds, rivers, streams, and washes whether perennial, intermittent or ephemeral.

Waters of the United States. Notwithstanding the determination of an area’s status by the city, state or federal agency, for the purposes of the Clean Water Act, the final authority regarding Clean Water Act jurisdiction remains with EPA. Subject to other determination by EPA, “waters of the United States” shall be deemed to be traditionally navigable waters and their tributaries that have at a minimum continuous seasonal flow or have a significant nexus regarding the chemical, physical or biological integrity of the navigable water. Generally roadside ditches and small washes and gullies characterized by low, infrequent, or low duration flows will not be considered “waters of the United States.” [Code 2006 § 14-1-3. Ord. 2007-17, 11-13-2007; Ord. 2014-06 § 1, 5-27-2014; Res. 2014-10 Exh. A, 5-27-2014].

13.50.040 Applicability.

The provisions of this chapter are applicable to all water entering the public storm drain system, waters of the United States, and water watercourses within the city limits, whether generated on any developed or undeveloped lands, unless explicitly exempted by an AZPDES general permit. [Code 2006 § 14-1-4. Ord. 2007-17, 11-13-2007; Ord. 2014-06 § 1, 5-27-2014; Res. 2014-10 Exh. A, 5-27-2014].

13.50.050 Responsibility for administration.

The city engineer shall administer, implement, and enforce the provisions of this chapter. The city engineer may designate other employees to exercise powers and perform duties under the provisions of this chapter. The authorities granted to the city engineer under the provisions of this section are subject to SCC [2.55.010\(B\)](#) as to relationship to the city manager. In the case of overlapping authority regarding wastewater discharge as defined in Division [I](#) of this title and the authority regarding discharge under this chapter, the director of wastewater is authorized to act on behalf of the city engineer. [Code 2006 § 14-1-5. Ord. 2007-17, 11-13-2007; Ord. 2014-06 § 1, 5-27-2014; Res. 2014-10 Exh. A, 5-27-2014].

13.50.060 Severability.

The provisions of this chapter are hereby declared to be severable. If any provision, clause, sentence, or paragraph of this chapter or the application thereof to any person, establishment, or circumstances shall be held invalid, such invalidity shall not affect the other provisions or application of this chapter. [Code 2006 § 14-1-6. Ord. 2007-17, 11-13-2007; Ord. 2014-06 § 1, 5-27-2014; Res. 2014-10 Exh. A, 5-27-2014].

13.50.070 Lot Drainage.

13.50.071 It shall be unlawful for any person or entity to alter any natural drainage course, topography, or existing drainage facility in such a way as to damage or endanger by flooding, erosion, nuisance water or any other means, any public or private property or improvements without written approval of the City Engineer. For purposes of this subsection, "alter" includes to change any surface sheet flow by obstruction or diversion through the erection of fences, berms, curbs, or any other excavation, fill or structure, if such modification will change flow in any existing drainage course or facility.

13.50.072 It shall be unlawful to change the quality, flow rates or flow patterns of surface runoff where it enters or exits a parcel, unless authorized in writing by the City Engineer.

Formatted: Font: Arial, Bold, Font color: Red

Formatted: Font: Arial, Bold, Font color: Red

Formatted: Font: Arial, 12 pt, Font color: Red, Strikethrough, Pattern: Clear

~~13.50.070~~080 Discharge prohibitions.

A. All illicit discharges to the public storm drain system are prohibited. These include, but are not limited to:

1. Discharges that are a source of pollutants, including discharges through connections that are a source of pollutants.
2. Discharge of soil, rock, trash, garbage and other waste.
3. Maintaining, establishing, or using a connection that allows a discharge.
4. Discharge from commercial car washing, mobile car washing, or impervious surface pressure washing operations.
5. Discharge from concrete washing.
6. Discharge of oils, fuels, paints, greases.
7. Discharge of grit and sand from grinding.
8. Discharge from carpet cleaning.
9. Discharge of chlorinated water from spas, swimming pools and similar facilities.
10. Discharge resulting from misrepresentation of the nature of discharge on an application, a plan, permit, or certification.
11. Discharge not disclosed on an application, plan, permit or certification.
12. Discharge of wastewater as defined in Division 1 of this title and this chapter.
13. Continuing a discharge that has not been permitted by the city.

B. The prohibition regarding illicit discharge includes, without limitation, illicit connections made in the past, regardless of whether the connection was permissible under law or practices applicable or prevailing at the time of construction. [Code 2006 § 14-1-7. Ord. 2007-17, 11-13-2007; Ord. 2014-06 § 1, 5-27-2014; Res. 2014-10 Exh. A, 5-27-2014].

13.50.~~089090~~ Permitted non-storm water discharges.

A. The city has determined that the following discharges are not significant contributors of pollutants to the municipal MS4s and are considered allowable non-storm water discharges, unless the city determines in specific instances that the discharge

contributes to a violation of the AZPDES general permit or other permit(s) under which the city is permitted to operate its MS4:

1. Water line flushing;
2. Landscape irrigation;
3. Diverted stream flows;
4. Rising groundwaters;
5. Uncontaminated groundwater infiltration;
6. Uncontaminated pumped groundwater;
7. Discharges from potable water sources;
8. Foundation drains;
9. Air conditioning condensate;
10. Irrigation water;
11. Springs;
12. Water from crawl space pumps;
13. Footing drains;
14. Lawn watering;
15. Individual residential car washing;
16. Discharges from riparian habitats and wetlands;
17. De-chlorinated swimming pool and spa discharges;
18. Street wash water; and
19. Discharges of flows from emergency fire fighting activities.

B. The city permits discharges allowed under the AZPDES de minimis general permit, and the city will rely on the state to enforce the provisions regarding these discharges under that permit. The city may, however, require a person to demonstrate that a

discharge is subject to that permit and that such discharge does not result in creation of a nuisance or other condition that violates the city of Sedona City Code.

C. Discharge allowed under separate permits issued by ADEQ are allowed; provided, that the permit conditions are adhered to.

D. Discharges which have been managed using BMPs that are appropriate to the facility at the time of the discharge and properly maintained shall be considered allowable.

E. It shall be the responsibility of the person discharging to demonstrate through testing, records, plans and other documents that the discharge is allowable under this chapter. The city may require such demonstration for any facility connected to the MS4 directly or indirectly. [Code 2006 § 14-1-8. Ord. 2007-17, 11-13-2007; Ord. 2014-06 § 1, 5-27-2014; Res. 2014-10 Exh. A, 5-27-2014].

13.50.~~099~~100 Plan review, inspections, access, and reports.

A. The city shall require that any person submitting a grading, building, or other improvement plan disclose if illicit discharge, storm water, or permitted non-storm water discharge of any type to the MS4 may occur as a result of, or in conjunction with, the implementation of the plan. To the extent that the discharge would be an illicit discharge, if connected to the MS4, the plan shall include BMP measures to remove or prevent the illicit discharge during and after construction of the improvement or project. The BMPs shall be subject to approval of the city engineer.

B. Persons shall maintain the BMPs during and after construction. This shall apply to persons initiating a project and to heirs and assigns. Changes to the BMPs approved at the time of a project implementation shall be sent to the city in writing. The revised BMPs shall be at least as effective in preventing pollution as the original BMPs or as then currently required by the city. The city reserves the right to require changes in BMPs as necessary to assure that discharges to the MS4 are of a quantity and quality that the city will not be in violation of the permits under which it is allowed to discharge storm water.

C. The city shall be granted access to all facilities and lands discharging any water or other material to the MS4.

D. Persons further developing parcels and/or lots that are part of a larger development, regardless of the time elapsed, shall utilize current BMP methods that are at least as effective as those identified in the storm water pollution prevention plan for the larger development or necessary to comply with regulations, laws, and codes current at the time of further developing, whichever is more stringent. Appropriate permits required by the state shall be acquired by further developers.

E. Site-specific storm water pollution prevention plans shall be developed for all construction projects one acre or greater in size. The site-specific plan shall identify the minimum BMPs to be utilized upon further development of the project area, when the person submitting the plan will not develop the entire project through building occupancy or other full development intent. Smaller areas may develop a site-specific plan or provide a notice of intent to abide by the city's general storm water pollution guidelines. The notice of intent shall be of a format approved by the city engineer and shall at minimum contain the following:

1. The name of the development as applicable;
2. The name of the property owner;
3. The name of the person responsible for compliance with the pollution prevention plan;
4. The anticipated time frame for constructing the project;
5. A statement to be signed by the responsible person and the property owner stating:

The responsible person and the person owning the property for which this notice of intent is submitted agrees to require that all construction work and related activity be conducted in accordance with the Sedona City Code requires and the requirements of the city of Sedona General Storm Water Pollution Prevention Guidelines. Persons further understands that failure to meet the mentioned requirements will be sufficient cause for the City to restrict or stop work on the property until the requirements are met. Also Persons shall additionally be subject to other actions under law.

F. The city engineer shall develop, publish, and update from time to time general storm water pollution guidelines. These guidelines shall at minimum address pollution caused by soil erosion, motor oil, trash, and landscape debris. [Code 2006 § 14-1-9. Ord. 2007-17, 11-13-2007; Ord. 2014-06 § 1, 5-27-2014; Res. 2014-10 Exh. A, 5-27-2014].

G. Drainage reports and construction plans for development and/or improvement of properties within the City of Sedona are reviewed and approved by the City for general conformance with the City's Ordinances, policies and standards. The City assumes no responsibility or liability for insufficient design and/or improper construction. Review and approval by the City does not absolve the owner, developer, design engineer, or contractor of liability for inadequate design or poor construction. The design engineer has the responsibility to design graded Improvements and drainage facilities that meet the standards of practice for the industry and promote public safety. Compliance with the regulatory elements, policies, and design standards documented herein, does not imply a guarantee that properties will be free from flood, geologic, and geotechnical related damage and failures. The City and its officials, employees, and contract reviewers, assume no liability for information, data, or conclusions prepared by private engineers and makes no warranty expressed or implied in its review/approval of grading and drainage projects.

13.50.~~400~~110 Suspension of MS4 access.

The city may, without prior notice, suspend MS4 discharge access when such suspension is necessary to stop an actual or threatened discharge, which presents or may present imminent and substantial danger to the environment, or to the health or welfare of persons, or to the MS4. If the violator fails to comply with a suspension order issued in an emergency, the city may take such steps as deemed necessary to prevent or minimize damage to the MS4, or to minimize danger to persons. [Code 2006 § 14-1-10. Ord. 2007-17, 11-13-2007; Ord. 2014-06 § 1, 5-27-2014; Res. 2014-10 Exh. A, 5-27-2014].

13.50.~~440~~120 Industrial or construction activity discharges.

Any person subject to an industrial or construction activity AZPDES/NPDES storm water discharge permit shall comply with all provisions of such permit. Proof of compliance with said permit may be required. An authorized representative of the city shall be permitted to enter and inspect facilities subject to regulation under industrial or construction activity permits at reasonable times and as often as may be necessary to determine compliance with this chapter. If a discharger has security measures in effect which require proper identification and clearance before entry into its premises, the

discharger shall make the necessary arrangements to allow access to representatives of the city. [Code 2006 § 14-1-11. Ord. 2007-17, 11-13-2007; Ord. 2014-06 § 1, 5-27-2014; Res. 2014-10 Exh. A, 5-27-2014].

13.50.~~120~~130 Suspension due to the detection of illicit discharge.

Any person discharging to the MS4 in violation of this chapter may be subject to MS4 access termination if such termination would abate or reduce an illicit discharge. The city will notify a violator of the proposed termination date of its MS4 access. The violator may petition the city storm water management section for a reconsideration and hearing. A person commits an offense if the person reinstates MS4 access to premises terminated pursuant to this section, without the prior approval of the city. [Code 2006 § 14-1-12. Ord. 2007-17, 11-13-2007; Ord. 2014-06 § 1, 5-27-2014; Res. 2014-10 Exh. A, 5-27-2014].

13.50.~~130~~140 Watercourse protection.

Every person owning property through which a watercourse passes, or such person's lessee, shall keep and maintain that part of the watercourse within the property free of trash, debris, excessive vegetation, and other obstacles that would pollute, contaminate, or significantly retard the flow of water through the watercourse. In addition, the owner or lessee shall maintain existing privately owned structures within or adjacent to a watercourse, so that such structures will not become a hazard to the use, function, or physical integrity of the watercourse. All maintenance activities must be in compliance with federal, state and municipal regulations. [Code 2006 § 14-1-13. Ord. 2007-17, 11-13-2007; Ord. 2014-06 § 1, 5-27-2014; Res. 2014-10 Exh. A, 5-27-2014].

13.50.~~140~~150 Notification of spills.

The owner, operator, or the person who has control of the source or location of any potential spill or release, which may result in a discharge that is not in compliance with this chapter, shall:

- A. Have a written storm water pollution plan or a written corrective action plan utilizing BMPs for the involved facility.
- B. Post notices to employees containing information about whom to contact and what procedures to follow in the event of an accidental discharge or spill.
- C. In the event of a spill, promptly take all reasonable safety precautions including, if appropriate, calling 911 and completing the following steps:
 - 1. Proceed with containment and cleanup in accordance with:
 - a. The orders of an involved health and safety agency, or if no such orders have been issued;
 - b. The orders of an authorized representative, or if no such orders have been issued;
 - c. The storm water pollution prevention plan or approved corrective action plan utilizing best management practices for the involved facility.
 - 2. Notify the city engineer and the Arizona Department of Environmental Quality of the release by telephone before noon of the next working day.
 - 3. Provide written notification, within five working days, to the city engineer of the type, volume, cause of the discharge, corrective actions taken, and measures to be taken to prevent future occurrences. [Code 2006 § 14-1-14. Ord. 2007-17, 11-13-2007; Ord. 2014-06 § 1, 5-27-2014; Res. 2014-10 Exh. A, 5-27-2014].

13.50.150160 Enforcement.

- A. *Notice of Violation, Corrective Action, and Penalties.*
 - 1. Upon discovery of a violation of this chapter, the city engineer, or authorized representative, may issue to the violator a written notice stating the nature of the violation, the corrective action required, the time frame for corrective action, and the penalties for continued noncompliance. The statement shall inform the owner or occupant that failure to pay the penalties will result in a lien against the property. The notice shall be served either by personal service or certified mail, upon the

owner, the owner's agent, the occupant, or the lessee. The notice may also be delivered by posting upon the facility at location(s) where it is likely to be seen. The notice may also require the violator to:

- a. Submit a corrective action plan to the city engineer indicating the cause of the violation, corrective actions to prevent recurrence, and a proposed compliance schedule;
 - b. Pay all costs of sampling and analysis, as well as costs for laboratory sample analysis;
 - c. Clean up any material that has left the property or has the potential to impact storm water runoff, ensure that the cleanup has been completed, and make changes in operations to prevent future releases;
 - d. Obtain and pay for the services of a qualified person to oversee and certify that corrective actions needed to resolve the violation have been completed;
 - e. Prepare and implement a best management practices plan to prevent storm water pollution, regardless of AZPDES/NPDES requirements;
 - f. Stop work on clearing, dredging, grading, excavating, storing, transporting, and/or filling of land, new construction, improvements, alterations, or additions;
 - g. Stop any activity that is in violation of this chapter;
 - h. Abate, within the time specified in the notice, any condition that is in violation of this chapter; and
 - i. Abate immediately any condition in violation of this chapter, if the city engineer or authorized representative determines that such condition presents an immediate threat to public health, safety, or the environment.
2. If violator refuses or is unable to immediately abate a condition that presents an immediate threat to public health, safety or the environment, the city may use all means necessary to abate the incident to protect the public health, safety or the environment and the city may charge all costs of such abatement to the violator.
 3. The city may approve the compliance schedule or corrective action plan utilizing best management practices submitted by the violator, or may require an alternative

compliance schedule or corrective action plan utilizing best management practices. This shall be done within the period specified in the notice. If the city discovers a condition that is likely to cause or is causing a discharge that threatens public health, safety or the environment, mitigation may include an immediate cessation of activity and abatement.

4. The remedies in this section are cumulative and the city may seek one or more such remedies.

5. It is a civil infraction for any person to violate this section or fail to comply with a notice of violation issued under this section.

6. Any person violating this section shall be liable to the city for all damages, costs, fines and penalties incurred by the city as a result, and shall defend, indemnify, and hold harmless the city against any resulting claims, liabilities or damages.

B. *Appeal of Violation.* Any person receiving a notice of violation may appeal the determination. The notice of appeal must be received by the city engineer within 10 calendar days from the date of the notice:

1. The appeal must be in writing, state the objection to the notice of violation, provide a mailing address for a response, and be mailed or delivered to the city engineer.

2. The city engineer may, within 10 working days of the receipt of an appeal, provide a written response to the person appealing which shall be delivered either by mail or by personal delivery. No response within 10 working days shall be deemed to be a denial of the appeal.

3. Appeal of the city engineer response or lack thereof to the notice of appeal shall be in accordance with Chapter [3.10](#) SCC if the claim is monetary in nature. The cause of action shall be deemed the notice of violation.

4. If the claim or demand is other than solely monetary in nature, appeal of the city engineer response or lack thereof shall be made to the city manager. Notice of such appeal shall be mailed to the city attorney who shall schedule a hearing to be conducted by the city manager, who shall admit all probative and reliable evidence without regard to formal rules of evidence or procedure. The person requesting an appeal may be heard in person and/or by an authorized representative at such

hearing. Following the hearing, the city manager shall issue a decision as to whether the notice of violation was supported by the evidence.

5. Appeal of the city manager decision may be made in a court of competent jurisdiction.

C. *Cost of Abatement of the Violation.* Within 30 calendar days after abatement of the violation, the owner of the property will be notified of the cost of abatement, including administrative costs. The property owner may file a written protest objecting to the amount of the assessment within 15 calendar days. If the amount due is not paid within 15 calendar days or by the time in which to file for an appeal is expired, the charges shall become a special assessment against the property and shall constitute a lien on the property for the amount of the assessment. The assessment shall be recorded in the office of the Yavapai County recorder or Coconino County recorder, including the date, amount of the assessment, and the legal description of the property against which the assessment is made. From the date of its recording, the assessment shall be a lien on the property and shall accrue interest at the rate prescribed by A.R.S. Section [44-1201](#). The city shall have the right to bring an action to enforce the lien in the superior court of Yavapai County at any time after the recording of the assessment, but failure to enforce the lien by such action shall not affect its validity. The recorded assessment shall be prima facie evidence of the truth of all matters recited therein, and of the regularity of all proceedings prior to the recording of the assessment.

D. *Injunctive Relief.* It shall be unlawful for any person to violate any provisions or to fail to comply with any of the requirements of this chapter. If a person has violated or continues to violate any provisions of this chapter, the city may petition the Yavapai County superior court for a preliminary or permanent injunction restraining the person from activities which would create further violations or compelling the person to perform abatement or remediation of the violation.

E. *Violations Deemed a Public Nuisance.* In addition to the enforcement processes and penalties provided herein, if any condition caused or permitted to exist in violation of any of the provisions of this chapter is a threat to public health, safety, and welfare, and is declared and deemed a nuisance by the city, such condition may be immediately abated or restored at the violator's expense, and/or a civil action to abate, enjoin, or otherwise compel the cessation of such nuisance may be taken. Nuisances under this chapter are also subject to enforcement under Chapter [8.10](#) SCC, Article I.

F. *Remedies Not Exclusive.* The remedies listed in this chapter are not exclusive of any other remedies available under any applicable federal, state or local law and it is within the discretion of the city to seek cumulative remedies. The city may recover all attorneys' fees, court costs, and other expenses associated with enforcement of this chapter, including sampling and monitoring expenses. [Code 2006 § 14-1-15. Ord. 2007-17, 11-13-2007; Ord. 2014-06 § 1, 5-27-2014; Res. 2014-10 Exh. A, 5-27-2014].

The Sedona City Code is current through Ordinance 2023-03, passed April 25, 2023.

Disclaimer: The city clerk's office has the official version of the Sedona City Code. Users should contact the city clerk's office for ordinances passed subsequent to the ordinance cited above.

[City Website: www.SedonaAZ.gov](http://www.SedonaAZ.gov)

[Code Publishing Company, A General Code Company](#)

Section 2. Savings Clause

If any section, subsection, sentence, clause, phrase, or portion of this Ordinance is for any reason held to be invalid or unconstitutional by the decision of any court of competent jurisdiction, such decision shall not affect the validity of the remainder of this Ordinance.

Section 3. Repeal

All other code provisions, ordinances or parts of ordinances in conflict with the provisions of this Ordinance are hereby repealed to the extent of such conflict as of the effective date hereof. Except as expressly amended herein, the provisions of the Chapter 13.50 shall be, and remain in full force and effect.

Section 4. Effective Date

The effective date of this Ordinance shall be 30 days following adoption by the City Council.

PASSED AND ADOPTED by the Mayor and Council of the City of Sedona, Arizona, this 22nd day of August, 2023.

Scott M. Jablow, Mayor

ATTEST:

JoAnne Cook, CMC, City Clerk

APPROVED AS TO FORM:

Kurt W. Christianson, City Attorney