



To Whom It May Concern:

The City of Sedona, Arizona is issuing Addendum #3 for the **PR-09 Posse Grounds Pickleball Courts Project**. For any proposal to be considered responsible and responsive, receipt of this Addendum must be acknowledged.

This Addendum contains 15 pages including this page, 0 changed bid sheets, 5 plan sheets, and 4 additional Technical Specification. Any changed bid sheets shall be used in lieu of the originally issued bid sheets in order to submit a responsive bid.

This Addendum changes, adds, or clarifies the following:

1. Section 2.2.2.11 of the technical specification's states Contractor shall have a USTC & TBA Certified Tennis Court/Pickleball Builder on staff. Proof of certification shall **not** be required of the successful bidder.
2. Contractor Shall install a 6-millimeter vapor barrier under concrete post tension slab.
3. The bid documents refer to two tone surface color. The bid schedule references three tone surfacing. Pickleball courts to be **three tone** surface color.
4. The court construction / surfacing guidelines the ASBA adheres to recommends Plexipave surfacing. The city approves Plexipave surfacing or approved equal. See attached Plexipave product information and installation instructions.
5. Contractor shall review changes to irrigation plan set sheets LOO, LO1, L-1, L-2 and L-3.

102 Roadrunner Dr.
Sedona, AZ 86336
(928) 204-7111
sedonaaz.gov
FAX (928) 282-5348

Public Works

Acknowledgement

I have received Addendum #3 for the **PR-09 Posse Grounds Pickleball Courts Project** as described above and acknowledge it as part of the Contract Documents for the project.

Signature

Date

Print Business Name

Addendum #3 issued by:



Kurt Harris, PE Director of Public Works / City Engineer

City of Sedona Pickleball Courts at Posse Grounds Park Irrigation Improvements

LOCATED IN A PORTION OF SECTION 12, TOWNSHIP 17 NORTH,
RANGE 5 EAST, GILA AND SALT RIVER MERIDIAN,
YAVAPAI COUNTY, ARIZONA.

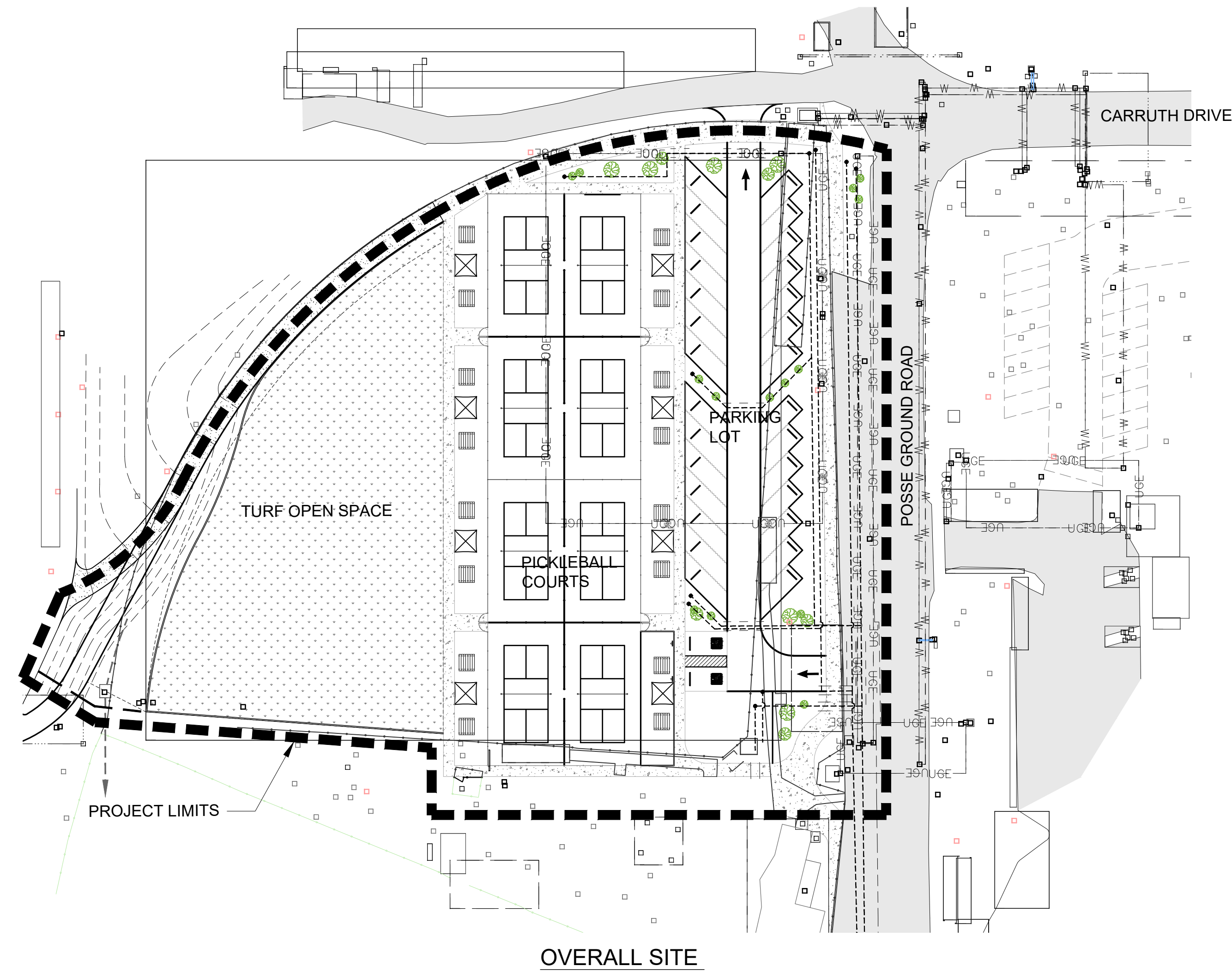

CONTACT INFORMATION:

OWNER
CITY OF SEDONA
PUBLIC WORKS DEPARTMENT
102 ROADRUNNER DRIVE
SEDONA, AZ 86336
PHONE: 928-204-7111
CONTACT:
EMAIL:

LANDSCAPE ARCHITECTURE:
NEILL + YOUNG ASSOCIATES, LLC.
3295 NORTH DRINKWATER BLVD., SUITE #12
SCOTTSDALE, ARIZONA 85251
CONTACT: TODD NEILL
PHONE: 480.949.2721
CELL: 602.617.2721
EMAIL: tneill@neillandyoung.com

SHEET INDEX

SHEET NO.	SHEET DESCRIPTION
1	L00 COVER SHEET
2	L01 KEY MAP / NOTES
3	L-1 IRRIGATION PLAN
4	L-2 IRRIGATION DETAILS
5	L-3 IRRIGATION DETAILS

APPROVALS

APPROVED:

BY: _____ DATE _____
KURT HARRIS
DIRECTOR OF PUBLIC WORKS/CITY ENGINEER

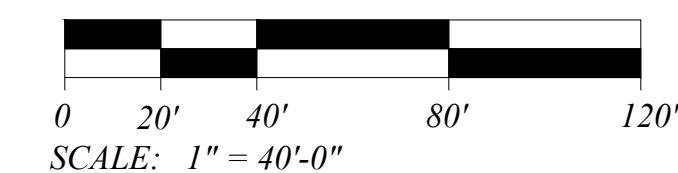
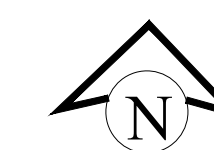

Landscapes Architecture
Landscape Planning
Urban Design
Phone 480.949.7127
Fax 480.949.2655
tneill@neillandyoung.com
3295 north drinkwater blvd
suite 12
scottsdale, arizona 85251



City of Sedona Posse Grounds Park
Pickleball Court Irrigation
102 Roadrunner Dr.
Sedona, AZ 86336

DATE: 04-08-24

JOB NO:

DRAWN BY: NYA

DESIGNED BY: NYA

SCALE:

REVISIONS: DATE:

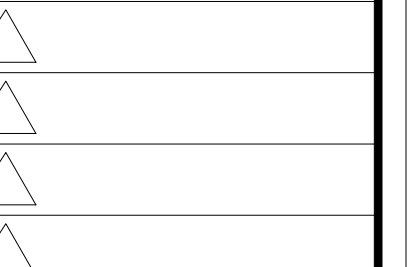

SUBMITTED FOR:

Not For Construction

SHEET NO.

L00

X OF

GENERAL NOTES:

1. THESE NOTES ARE TO BE USED FOR GENERAL REFERENCE IN CONJUNCTION WITH AND AS A SUPPLEMENT TO THE WRITTEN SPECIFICATIONS, APPROVED ADDENDUM, AND CHANGE ORDERS ASSOCIATED WITH THESE LANDSCAPE DRAWINGS.
2. A QUALIFIED SUPERVISOR SHALL BE PRESENT ON SITE AT ALL TIMES DURING CONSTRUCTION.
3. BEFORE WORK BEGINS ON THE PROJECT, THE LANDSCAPE CONTRACTOR SHALL REVIEW THE PROJECT WITH THE LANDSCAPE ARCHITECT AND/OR OWNER'S AUTHORIZED REPRESENTATIVE. THE LANDSCAPE ARCHITECT AND/OR OWNER'S AUTHORIZED REPRESENTATIVE IS TO APPROVE ANY OR ALL CHANGES PRIOR TO THE START OF ANY WORK.
4. LANDSCAPE CONTRACTOR SHALL INSPECT WITH THE OWNER'S AUTHORIZED REPRESENTATIVE ALL SIDEWALK AND CURB DEFECTS PRIOR TO BEGINNING WORK. ALL HARDSCAPE SHALL BE RE-INSPECTED DURING THE FINAL WALK-THRU. ANY DAMAGED AREAS SHALL BE REPAIRED AT THE CONTRACTOR'S EXPENSE.
5. VERIFY CRITICAL DIMENSIONS, REFERENCE POINT LOCATIONS, AND CONSTRUCTION CONDITIONS PRIOR TO INITIATING CONSTRUCTION., NOTIFY THE OWNER AND LANDSCAPE ARCHITECT IMMEDIATELY SHOULD CONFLICTS ARISE.
6. IT IS THE RESPONSIBILITY OF THE CONTRACTOR TO COORDINATE ALL CONSTRUCTION ELEMENT LOCATIONS WITH OTHER TRADES PRIOR TO INSTALLATION. THE CONTRACTOR SHALL BECOME FAMILIAR WITH THE LOCATIONS OF EXISTING AND FUTURE UNDERGROUND SERVICES AND IMPROVEMENTS WHICH MAY CONFLICT WITH THE WORK TO BE DONE. CONTACT BLUE STAKE AT 602-263-1100, 72 HOURS MINIMUM PRIOR TO INITIATING CONSTRUCTION. NOTIFY THE OWNER AND LANDSCAPE ARCHITECT IMMEDIATELY SHOULD CONFLICT ARISE.
7. OBSERVATION VISITS TO THE JOB SITE BY THE LANDSCAPE ARCHITECT DO NOT INCLUDE INSPECTIONS OF CONSTRUCTION METHODS AND SAFETY CONDITIONS AT THE WORK SITE. THESE VISITS SHALL NOT BE CONSTRUED AS CONTINUOUS AND DETAILED INSPECTIONS.
8. UNLESS OTHERWISE NOTED ON PLANS, DECOMPOSED GRANITE SHALL EXTEND UNDER SHRUBS AND BE RAKED UNIFORMLY ALONG WALK, SIDEWALK, AND CURBS.
9. LANDSCAPE CONTRACTOR SHALL PROVIDE BARRICADES AND TRAFFIC CONTROL ALONG PUBLIC STREETS IF REQUIRED DURING INSTALLATION.
10. REFER TO THE ENGINEERING DRAWINGS FOR DRAINAGE FLOWS. THE LANDSCAPE CONTRACTOR SHALL BE RESPONSIBLE THAT THESE ARE PROVIDED AND NOT IMPAIRED WITH OBSTRUCTIONS.
11. LANDSCAPE CONTRACTOR TO CONTACT LANDSCAPE ARCHITECT AND/OR OWNER'S AUTHORIZED REPRESENTATIVE BEFORE EACH APPLICATION OF PRE-EMERGENT FOR VERIFICATION.
12. BOULDERS TO BE SURFACE SELECT BOULDERS. ANY EXPOSED SURFACE SCARRING THAT MAY HAVE OCCURRED DURING TRANSPORTING OR CONSTRUCTION IS TO BE EONITED.

IRRIGATION NOTES:

1. ALL IRRIGATION EQUIPMENT TO BE LOCATED IN LANDSCAPE AREAS WITHIN PROPERTY BOUNDARIES OF THE PROJECT - ALL LINES AND EQUIPMENT ARE SCHEMATIC AND ARE SOMETIMES SHOWN IN ROADWAYS, SIDEWALKS, OR OUTSIDE PROPERTY LINES. THIS IS DONE FOR CLARITY PURPOSES ONLY.
2. DO NOT INSTALL THE IRRIGATION SYSTEM AS SHOWN ON THE DRAWINGS WHEN IT IS OBVIOUS IN THE FIELD THAT UNKNOWN OBSTRUCTIONS, GRADE DIFFERENCES, OR DIFFERENCES IN AREA DIMENSIONS EXIST THAT MIGHT NOT HAVE BEEN CONSIDERED IN THE ENGINEERING. SUCH OBSTRUCTIONS OR CONFLICTS SHOULD BE BROUGHT TO THE ATTENTION OF THE OWNER AND LANDSCAPE ARCHITECT IMMEDIATELY. IN THE EVENT THIS NOTIFICATION IS NOT PERFORMED, THE CONTRACTOR SHALL ASSUME FULL RESPONSIBILITY FOR ANY REVISIONS NECESSARY.
3. THE IRRIGATION SYSTEM DESIGN IS BASED ON A MINIMUM SOURCE PRESSURE OF 60 PSI, A MINIMUM OPERATING PRESSURE OF 30 PSI AND A MAXIMUM FLOW DEMAND OF 26 GPM. THE CONTRACTOR SHALL VERIFY WATER PRESSURES PRIOR TO CONSTRUCTION AND REPORT ANY DISCREPANCIES BETWEEN THE WATER PRESSURE INDICATED ON THE DRAWINGS AND THE ACTUAL PRESSURE READING AT THE IRRIGATION POINT OF CONNECTION TO THE LANDSCAPE ARCHITECT IMMEDIATELY.
4. ALL MATERIAL USED SHALL BE INSTALLED AS DETAILED. ALL IRRIGATION EQUIPMENT NOT OTHERWISE DETAILED OR SPECIFIED SHALL BE INSTALLED PER MANUFACTURER'S RECOMMENDATIONS AND SPECIFICATIONS. OWNER'S REPRESENTATIVE AND/OR LANDSCAPE ARCHITECT SHALL APPROVE ALL DEVIATION'S FROM DRAWINGS OR MATERIALS USED.
5. THE OWNER'S REPRESENTATIVE MAY, AT ANY TIME, TAKE AND ANALYZE SAMPLES OF MATERIALS AND EQUIPMENT FOR CONFORMITY TO SPECIFICATIONS. THE CONTRACTOR SHALL MAKE SUCH SAMPLES AVAILABLE UPON REQUEST. REJECTED MATERIAL SHALL BE IMMEDIATELY REMOVED FROM THE SITE AND REPLACED AT THE CONTRACTOR'S EXPENSE.
6. INSTALL BACKFLOW PREVENTION UNIT(S) PIPING BETWEEN THE POINT OF CONNECTION AND THE BPU PER LOCAL CODES. THE OWNER'S AUTHORIZED REPRESENTATIVE SHALL APPROVE THE FINAL LOCATION OF THE BPU. BACKFLOW PREVENTOR MUST BE SCREENED FROM VIEW.
7. CONTRACTOR SHALL BE RESPONSIBLE FOR SUPPLYING MATERIALS AND LABOR TO PROVIDE SPECIFIED ELECTRICAL SERVICE TO ALL CONTROLLER LOCATIONS. ALL ELECTRICAL WORK TO BE PER MANUFACTURER'S SPECIFICATIONS AND PER LOCAL CODE.
8. 24 VOLT WIRE SHALL BE 600V, UF, UL APPROVED, #14 GAUGE, SINGLE STRAND, PLASTIC INSULATED, COPPER WIRE. COMMON WIRE IS TO BE WHITE, CONTROL WIRE IS TO BE RED (USE NO BLACK WIRE). TAPE AND BUNDLE WIRE AT 10' ON CENTER. LAY BESIDE MAINLINE. SPLICE IN VALVE BOXES ONLY, USING MANUFACTURED EPOXY OR RESIN FILLED WIRE CONNECTORS. PROVIDE 18" SLACK AT EACH ELBOW IN MAIN LINE AND AT EACH REMOTE CONTROL VALVE. PULL ONE ADDITIONAL SPARE WIRE TO THE MOST DISTANT VALVE LOCATION FOR POTENTIAL FUTURE USE. COLOR OF EXTRA WIRE SHALL BE YELLOW.

PLANTING NOTES:

1. CLARIFICATION OF DISCREPANCIES BETWEEN THE CONSTRUCTION DOCUMENTS AND THE SITE SHOULD BE BROUGHT TO THE ATTENTION OF THE LANDSCAPE ARCHITECT.
2. ALL PLANT MATERIAL MUST MEET ANA SPECIFICATIONS.
3. THE LANDSCAPE ARCHITECT AND/OR OWNER'S REPRESENTATIVE RESERVES THE RIGHT TO REFUSE ANY PLANT MATERIAL HE DEEMS UNACCEPTABLE. ALL PLANT MATERIAL SHALL BE INSPECTED PRIOR TO INSTALLATION.
4. PLANTS TO BE LOCATED AWAY FROM OBSTACLES SUCH AS FIRE HYDRANTS, TRANSFORMERS, POWER POLES, AND LIGHT FIXTURES AS NECESSARY. DO NOT INSTALL PLANT MATERIAL IN ANY AREA WHICH WILL CAUSE HARM TO ADJACENT IMPROVEMENTS.
5. VERIFY PLANT QUANTITIES PRIOR TO INSTALLATION. QUANTITIES ARE LISTED FOR CONVENIENCE ONLY, THE ACTUAL NUMBER OF SYMBOLS INDICATED ON THE PLANTING PLANS SHALL HAVE PRIORITY OVER QUANTITIES DESIGNATED. NOTIFY THE LANDSCAPE ARCHITECT OF QUANTITY DISCREPANCIES OR UNLEVELED MASSINGS IMMEDIATELY.
6. PLANT TREES, SHRUBS, AND CACTI PLUMB, AND FACED TO GIVE THE BEST APPEARANCE OR RELATIONSHIP TO ADJACENT PLANTS OR VIEWS.
7. NOTIFY OWNER AND LANDSCAPE ARCHITECT IMMEDIATELY SHOULD SOIL CONDITIONS BE PRESENT WHICH WOULD PREVENT PROPER SOIL DRAINAGE AND ALLOW WATER TO STAND IN PLANTING PITS.
8. DOUBLE STAKE ALL TREES OUTSIDE ROOTBALL., EXCEPT FOR SALVAGED TREES.
9. LANDSCAPE CONTRACTOR TO PERFORM A SOILS TEST PRIOR TO LANDSCAPE CONSTRUCTION TO DETERMINE ANY NUTRIENT DEFICIENCIES. IF ANY DEFICIENCIES EXIST, IT SHALL BE THE RESPONSIBILITY OF THE CONTRACTOR TO AMEND THE SOIL ACCORDINGLY.
10. SIGNS REQUIRE SEPARATE APPROVALS AND PERMITS.
11. PLANTS IN THE RIGHT-OF-WAY SHALL NOT EXCEED THREE FEET IN HEIGHT, OR IN THE CASE OF TREES, BRANCHES SHALL BE PRUNED UP TO A HEIGHT OF SIX FEET.

COPYRIGHT © 2024 NEILL+YOUNG ASSOCIATES, LLC. ALL RIGHTS RESERVED. NO ALTERATIONS TO THESE PLANS ARE ALLOWED OTHER THAN AUTHORIZED NEILL+YOUNG EMPLOYEES. THIS DOCUMENT IS THE SOLE PROPERTY OF NEILL+YOUNG ASSOCIATES, LLC.

Landscape Architecture
 Land Planning
 Urban Design
 phone 480.949.7127
 fax 480.949.2655
 hne@neillyoung.com
 3295 north drinkwater blvd
 suite 12
 scottsdale, arizona 85251

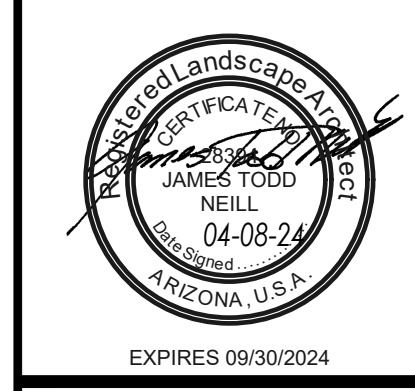
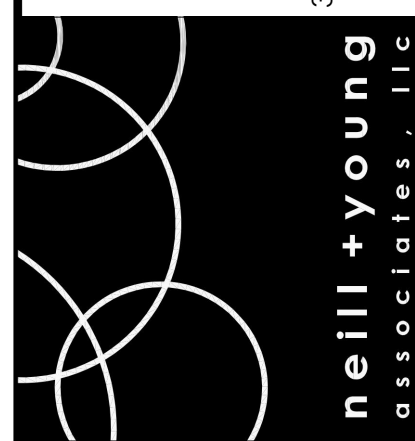

City of Sedona Posse Grounds Park
Pickleball Court Irrigation
 102 Roadrunner Dr.
 Sedona, AZ 86336

DATE:	04-08-24
JOB NO:	
DRAWN BY:	NYA
DESIGNED BY:	NYA
SCALE:	
REVISIONS:	DATE:
△	
△	
△	
△	
SUBMITTED FOR:	
	Not For Construction

SHEET NO.
L01
 X OF



CONTRACTOR SHALL VERIFY ALL EXISTING UTILITIES PRIOR TO CONSTRUCTION. NO ALTERATIONS TO THESE PLANS ARE ALLOWED OTHER THAN AUTHORIZED NEILL+YOUNG EMPLOYEES.
 THIS DOCUMENT IS THE SOLE PROPERTY OF NEILL+YOUNG ASSOCIATES.

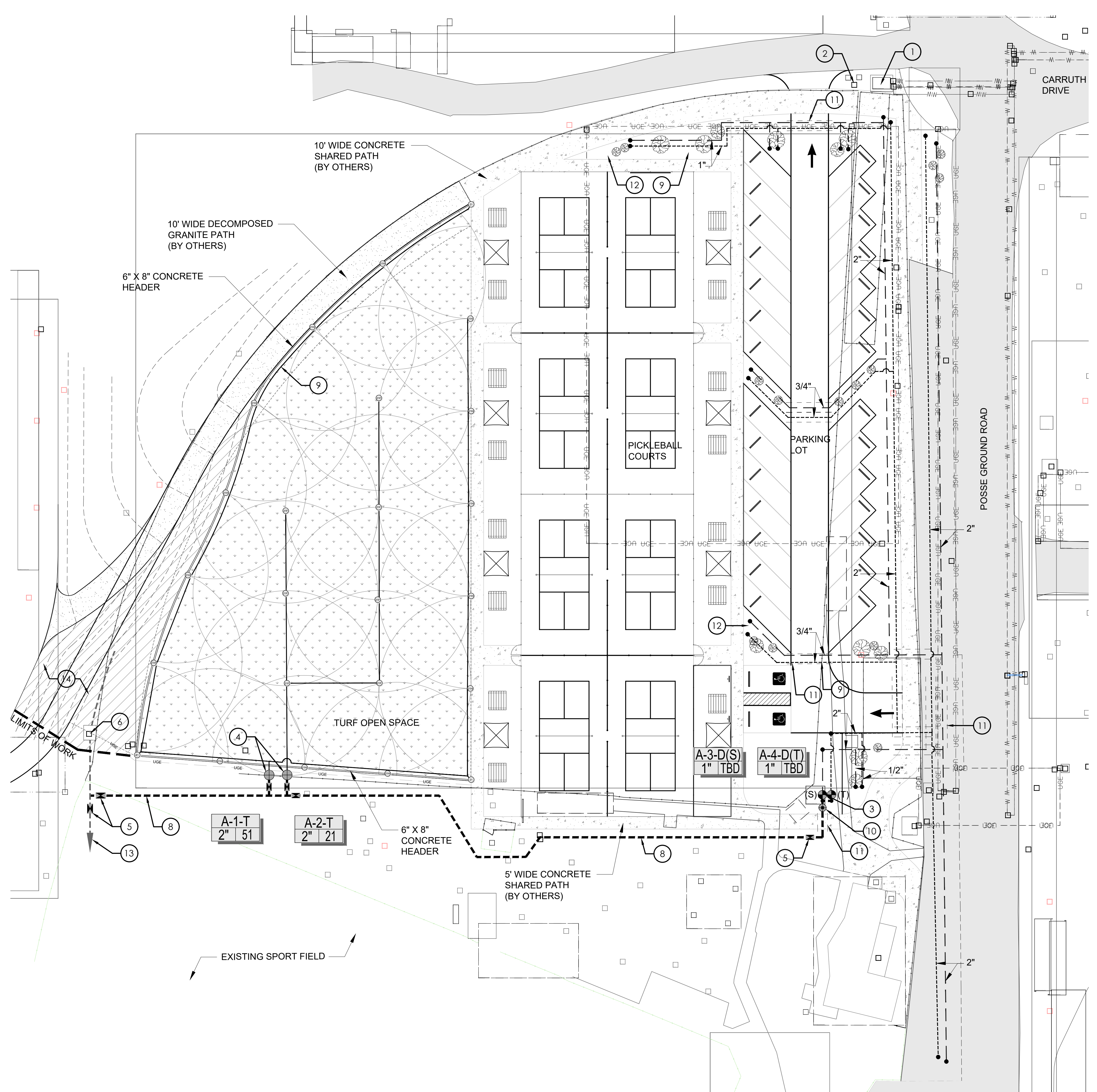

IRRIGATION SCHEDULE

SYMBOL	ITEMS	DESCRIPTION	REMARKS
MA	IRRIGATION METER	EXISTING (THE CONTRACTOR SHALL VERIFY SIZE OF IRRIGATION METER PRIOR TO CONSTRUCTION).	
BOOSTER PUMP	BOOSTER PUMP	T.B.D.	
NOT SHOWN	SECURITY ENCLOSURE	GUARDIAN ENCLOSURES Backflow Cage - GE-3, CONTRACTOR TO VERIFY SIZE WITH BACKFLOW	COLOR-TAN
	GATE VALVE	3" BRONZE GATE VALVE	INTAN BOX
	DRIP VALVE	RAIN BIRD (BRASS VALVE); 100-EBBCP-PRS-D (DRIP), ADD PRESSURE REGULATING FILTER; 1" PRBY FILTER	INTAN VALVE BOX
	TURF VALVE	RAIN BIRD (BRASS VALVE); 200-EBBCP-PRS-D (TURF)	INTAN VALVE BOX
	QUICK COUPLER	RAIN BIRD; 33-DRC 3/4" QUICK COUPLER WITH VINYL AND LASCO G13T-SWING JOINT.	
NOT SHOWN	EMITTERS	RAIN BIRD XBT-10-6-BLACK, RAIN BIRD XBT-20-6-RED	SEE EMITTER SCHEDULE
	TURF ROTORS	HUNTER I-20 (I-20-04-S5-PRD); BLUE 3.0 NOZZLE	
	PVC SLEEVING	SLEEVING SHALL BE PROVIDED FOR ALL MAINLINE PIPE, LATERAL PIPE, CONTROL WIRING, and DRIP LATERAL PIPE. COORDINATE WITH GENERAL CONTRACTOR FOR PLACEMENT UNDER PAVED SURFACES, TYP.	SEE SLEEVING SCHEDULE
	3" PVC MAINLINE	3" SCH 40 PVC MAINLINE	
	DRIP LATERAL (TREE)	PVC LATERAL, CLASS 200	SEE PIPE SCHEDULE
	DRIP LATERAL (SHRUB)	PVC LATERAL, CLASS 200	SEE PIPE SCHEDULE
	TURF LATERAL	SCH 40 PVC TURF LATERAL	SEE PIPE SCHEDULE
	END CAP	CARSON END CAP	SEE SCHEDULE

WATER PRESSURE NOTES

THE SYSTEM HAS BEEN DESIGNED FOR A REQUIRED MINIMUM STATIC PRESSURE OF 55 PSI AT METER. THE CONTRACTOR IS RESPONSIBLE FOR VERIFYING THE PSI PRIOR TO CONSTRUCTION. THE CONTRACTOR IS RESPONSIBLE FOR NOTIFYING THE OWNER'S REPRESENTATIVE OF ANY DISCREPANCY BETWEEN THE DESIGN PRESSURE OF THE IRRIGATION SYSTEM AND ANY DIFFERENCE FROM THE ORIGINAL FIELD MEASURED PSI NOTED ABOVE. IF THE CONTRACTOR FAILS TO NOTIFY THE OWNER'S REPRESENTATIVE OF SUCH DISCREPANCIES, THEN THE CONTRACTOR ASSUMES ALL LIABILITY AND COSTS ASSOCIATED WITH SYSTEM MODIFICATIONS TO ACCOMMODATE THE DESIGN PRESSURE. LOCATIONS OF MAINLINE AND LATERALS ARE SHOWN SCHEMATICALLY. COORDINATE FINAL LOCATION WITH THE CONTRACTOR AND OTHER TRADES PRIOR TO BREAKING GROUND. THE CONTRACTOR SHALL ENSURE THE LAYOUT OF ALL TURF HEADS/ROTORS TO HAVE HEAD-TO-HEAD COVERAGE.

IRRIGATION KEY NOTES

- EXISTING METER - SEE IRRIGATION SCHEDULE
- BACKFLOW PREVENTER - SEE IRRIGATION SCHEDULE
- AUTOMATIC IRRIGATION DRIP VALVE - SEE IRRIGATION SCHEDULE
- AUTOMATIC TURF VALVE - SEE IRRIGATION SCHEDULE
- GATE VALVE - SEE IRRIGATION SCHEDULE
- BOOSTER PUMP - SEE IRRIGATION SCHEDULE
- EXISTING IRRIGATION CONTROLLER - SEE IRRIGATION SCHEDULE
- MAINLINE - (LOCATIONS AS SHOWN ARE SCHEMATIC) COORDINATE FINAL LOCATION WITH GENERAL CONTRACTOR and OTHER TRADES PRIOR TO BREAKING GROUND.
- LATERAL LINES - (LOCATIONS AS SHOWN ARE SCHEMATIC) COORDINATE FINAL LOCATION WITH GENERAL CONTRACTOR AND OTHER TRADES PRIOR TO BREAKING GROUND.
- QUICK COUPLER - SEE IRRIGATION SCHEDULE
- PVC IRRIGATION SLEEVE - SEE IRRIGATION SCHEDULE (GENERAL CONTRACTOR SHALL PROVIDE SCH 80 PVC SLEEVING UNDER ALL NEW STREETS PER CITY OF SEDONA STANDARDS).
- FLUSH END CAP - SEE IRRIGATION SCHEDULE.
- EXISTING MAINLINE - THE CONTRACTOR SHALL VERIFY LOCATION AND SIZE OF MAINLINE PRIOR TO CONSTRUCTION).
- DECOMPOSED GRANITE TOP DRESSING TO MATCH TO EXISTING.

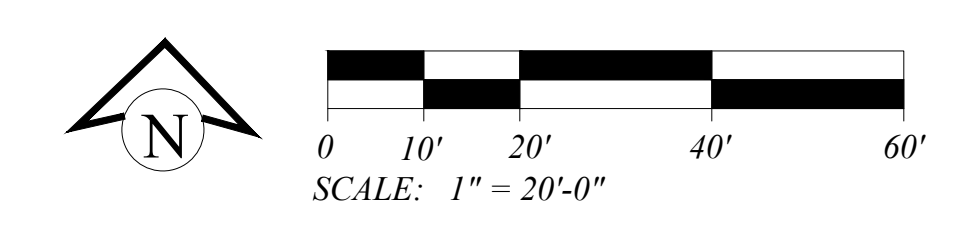
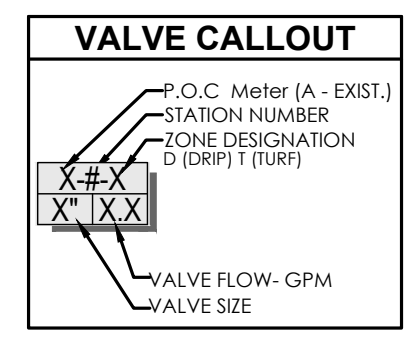

Landscape Architecture
 Land Planning
 Urban Design
 phone 480.949.7127
 fax 480.949.2655
 neill@neillyoung.com
 3295 north drinkwater bvd
 suite 12
 scottsdale, arizona 85251
neill + young
 associates, llc

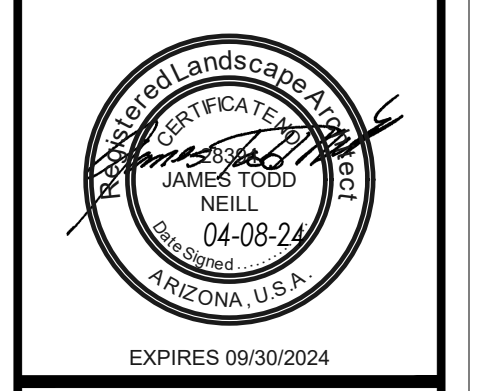

City of Sedona Posse Grounds Park
Pickleball Court Irrigation
 102 Roadrunner Dr.
 Sedona, AZ 86336

DATE:	04-08-24
JOB NO:	
DRAWN BY:	NYA
DESIGNED BY:	NYA
SCALE:	
REVISIONS:	DATE:
SUBMITTED FOR:	Not For Construction
SHEET NO.	L-1
	X OF

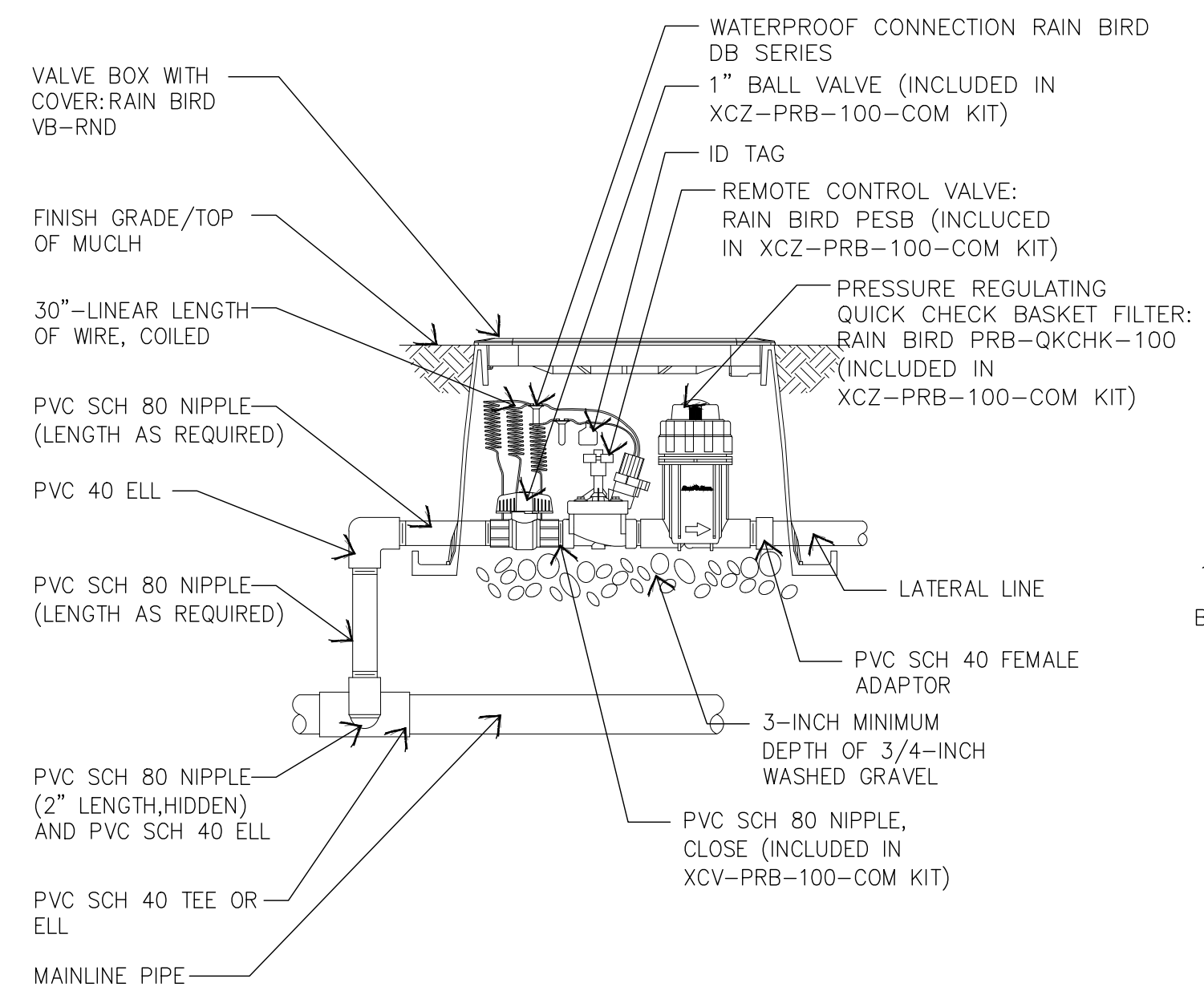

1 AUTOMATIC VALVE ASSEMBLY
SCALE: N.T.S. ID-16

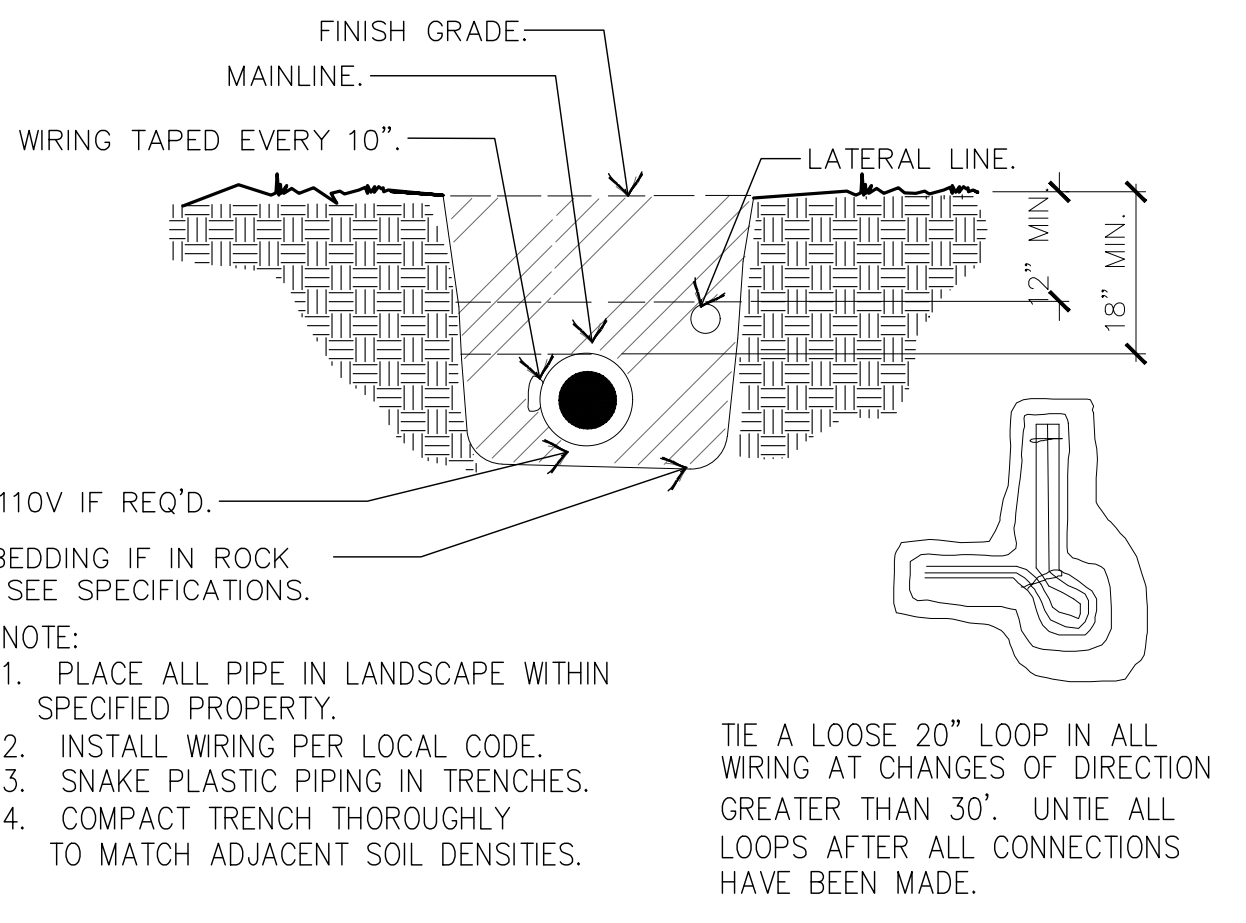

2 TRENCHING DEPTH DETAIL
SCALE: N.T.S.

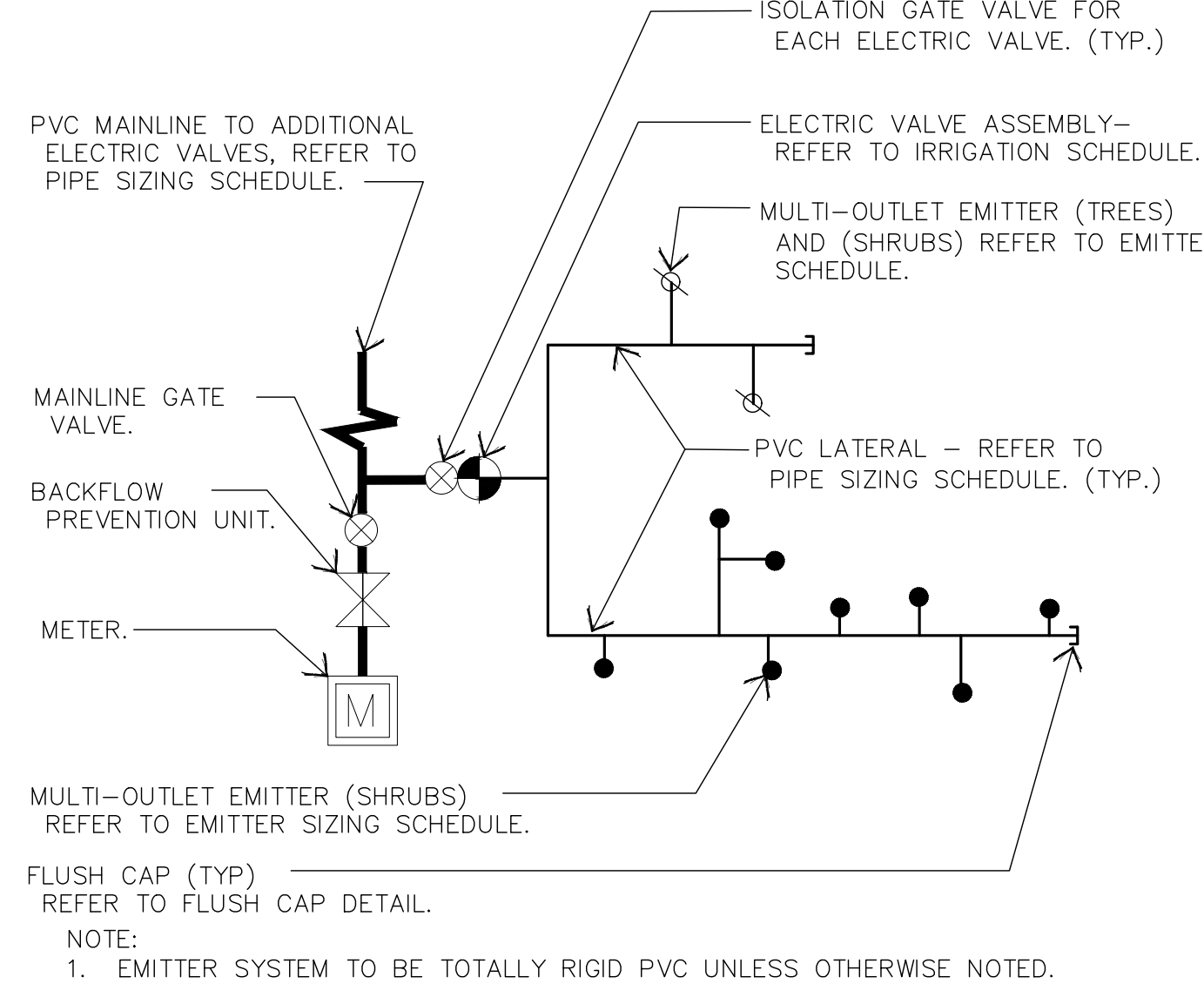

3 PIPE LAYOUT DETAIL
SCALE: N.T.S. ID-2

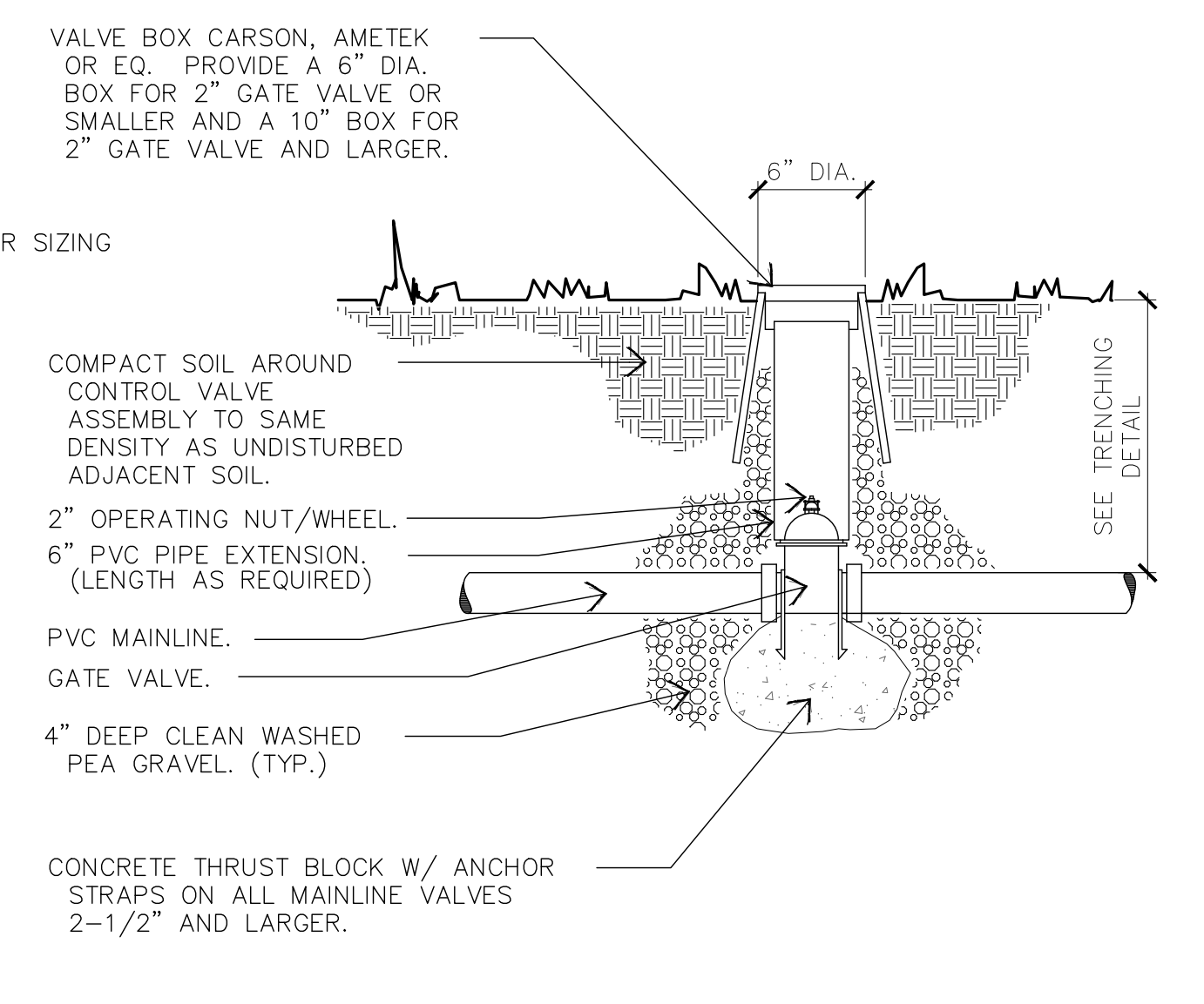

4 GATE VALVE DETAIL
SCALE: N.T.S. ID-20

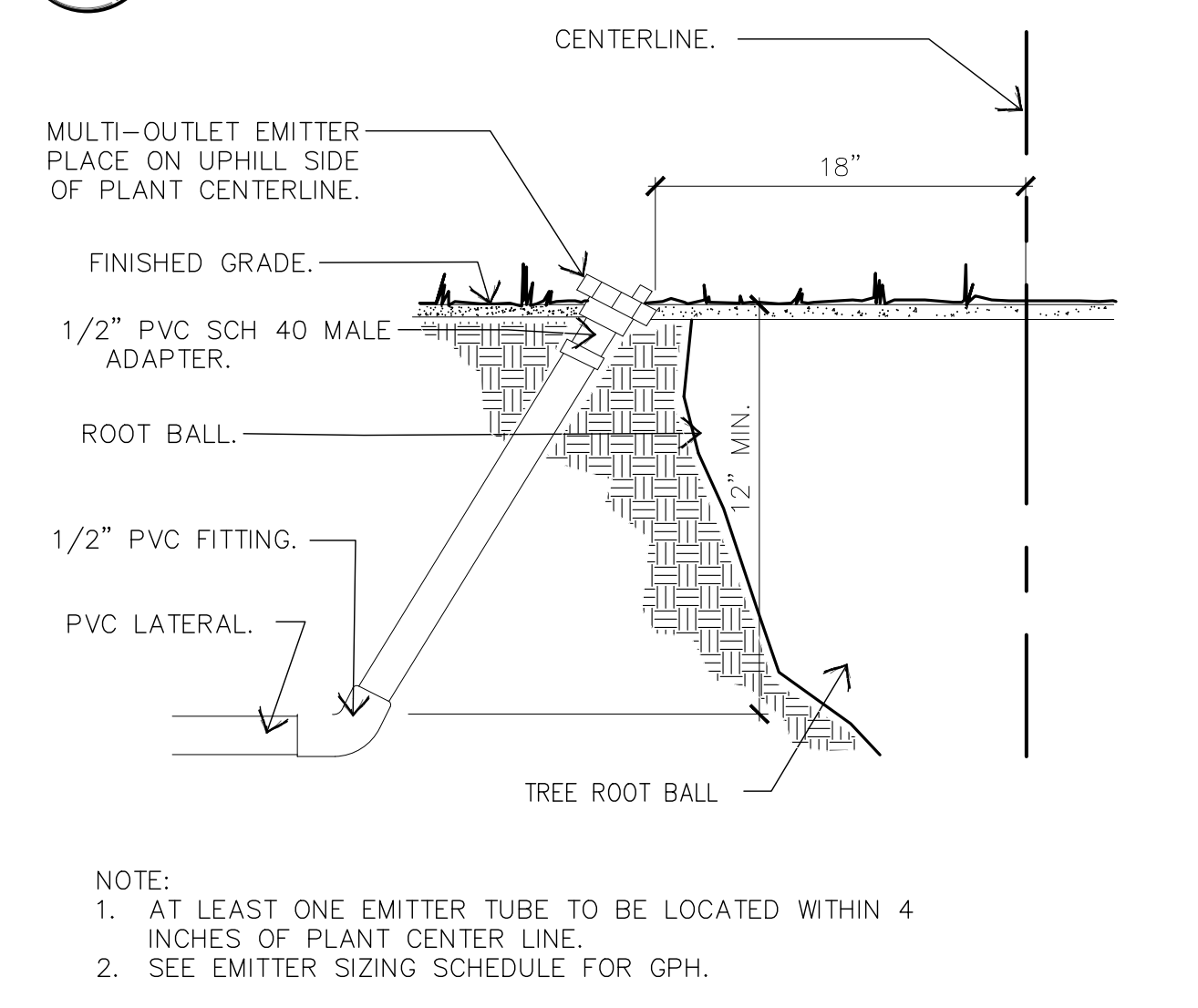

5 MULTI OUTLET EMITTER @ TREES
SCALE: N.T.S. ID-15

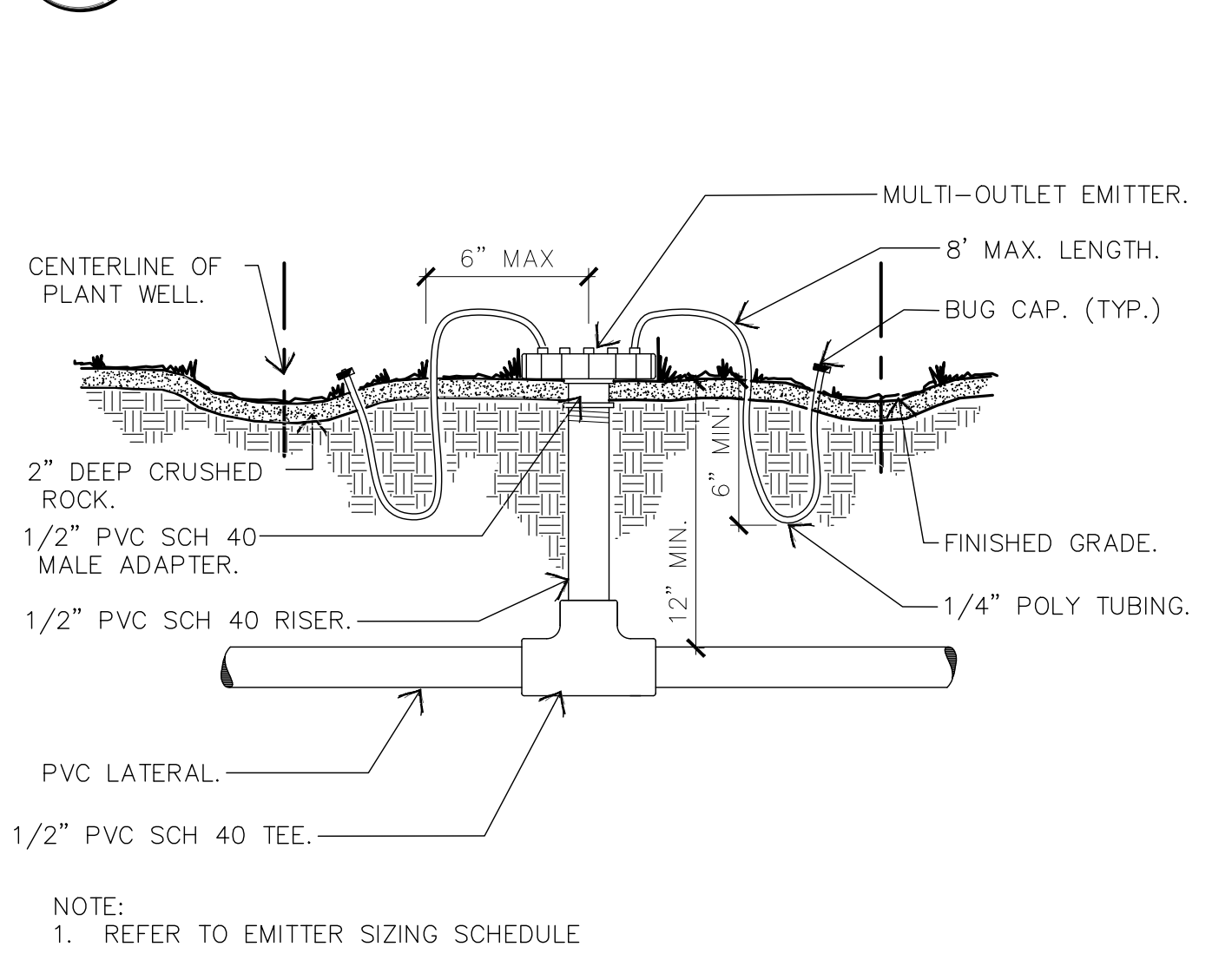

6 MULT-OUTLET EMITTER @ SHRUBS
SCALE: N.T.S. ID-9

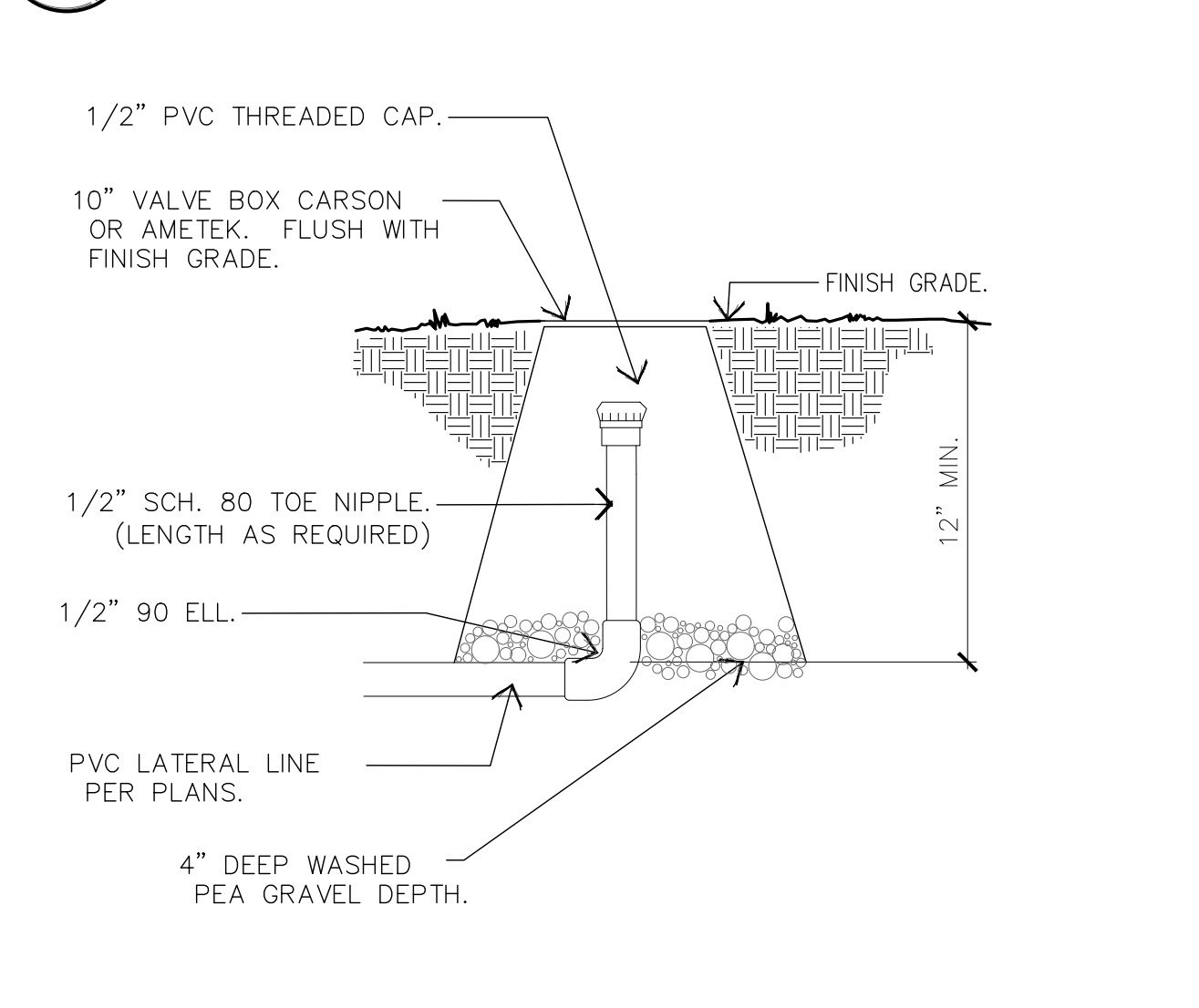

7 FLUSH CAP DETAIL
SCALE: N.T.S. ID-10

8 EMITTER SIZING SCHEDULE
SCALE: N.T.S. ID-13

PLANT SIZE	FLOW/PER PLANT	EMITTER/BUBBLER	QTY
ACCENTS	1 GPH	Rain Bird XBT-10-6:Black	1 - 1 GPH Outlet
1 GAL PLANTS	1 GPH	Rain Bird XBT-10-6:Black	1 - 1 GPH Outlet
5 GAL PLANTS	2 GPH	Rain Bird XBT-10-6:Black	2 - 1 GPH Outlets
DESERT TREES	6 GPH	Rain Bird XBT-10-6:Black	6 - 1 GPH Outlets
RED PUSH-TREES	24 GPH	Rain Bird XBT-20-6:Red	12 - 2 GPH Outlets

NOTE:
1. PROVIDE IRRIGATION TO 4-5 SHRUBS MAX PER MULTI PORT EMITTERS. (TYP.)
2. DO NOT PROVIDE IRRIGATION TO CACTUS.

NOTE:
ALL PIPE SLEEVES SHALL BE SCHEDULE 40 PVC AND INSTALLED WITH A MINIMUM OFFSET AT THE JOINTS TO PERMIT EASY INSTALLATION AND REMOVAL OF THE IRRIGATION LINES.
ALL PIPE SLEEVES INSTALLED UNDER NEW STREETS SHALL BE SCHEDULE 80 PVC PER CITY OF BUCKEYE STANDARDS. SLEEVES SHALL EXTEND AT LEAST 12" BEYOND THE EDGES OF THE PAVEMENT. SIZE OF SLEEVES SHALL BE AS FOLLOWS:

SLEEVING SCHEDULE

PIPE SIZE	MIN. SLEEVE SIZE	PIPE SIZE	MIN. SLEEVE SIZE
1/2"	2"	2", 2-1/4"	4"
3/4"	2-1/2"	3", 4"	6"
1", 1-1/4", 1-1/2"	3"		

PIPE SIZING SCHEDULE

PIPE SIZE	FLOW (GPM)	PIPE SIZE	FLOW (GPM)
1/2"	0 - 5	2"	36 - 80
3/4"	6 - 10	2-1/2"	61 - 60
1"	11 - 15	3"	81 - 120
1-1/4"	16-25	3 1/2"	121 - 150
1-1/2"	26 - 35	4"	151 - 200

NOTE:
ALL MAINLINE PIPE 2" AND LARGER SHALL BE SCHEDULE 40 PVC RING-TIGHT PIPE. ALL DRIP LATERAL PIPE ABOVE 1/2" SHALL BE MINIMUM CLASS 200 AND ALL 1/2" LATERAL PIPE SHALL BE CLASS 315. ALL TURF LATERAL SHALL BE SCHEDULE 40 PVC.

9 SLEEVE/PIPE SIZE
SCALE: N.T.S. ID-8

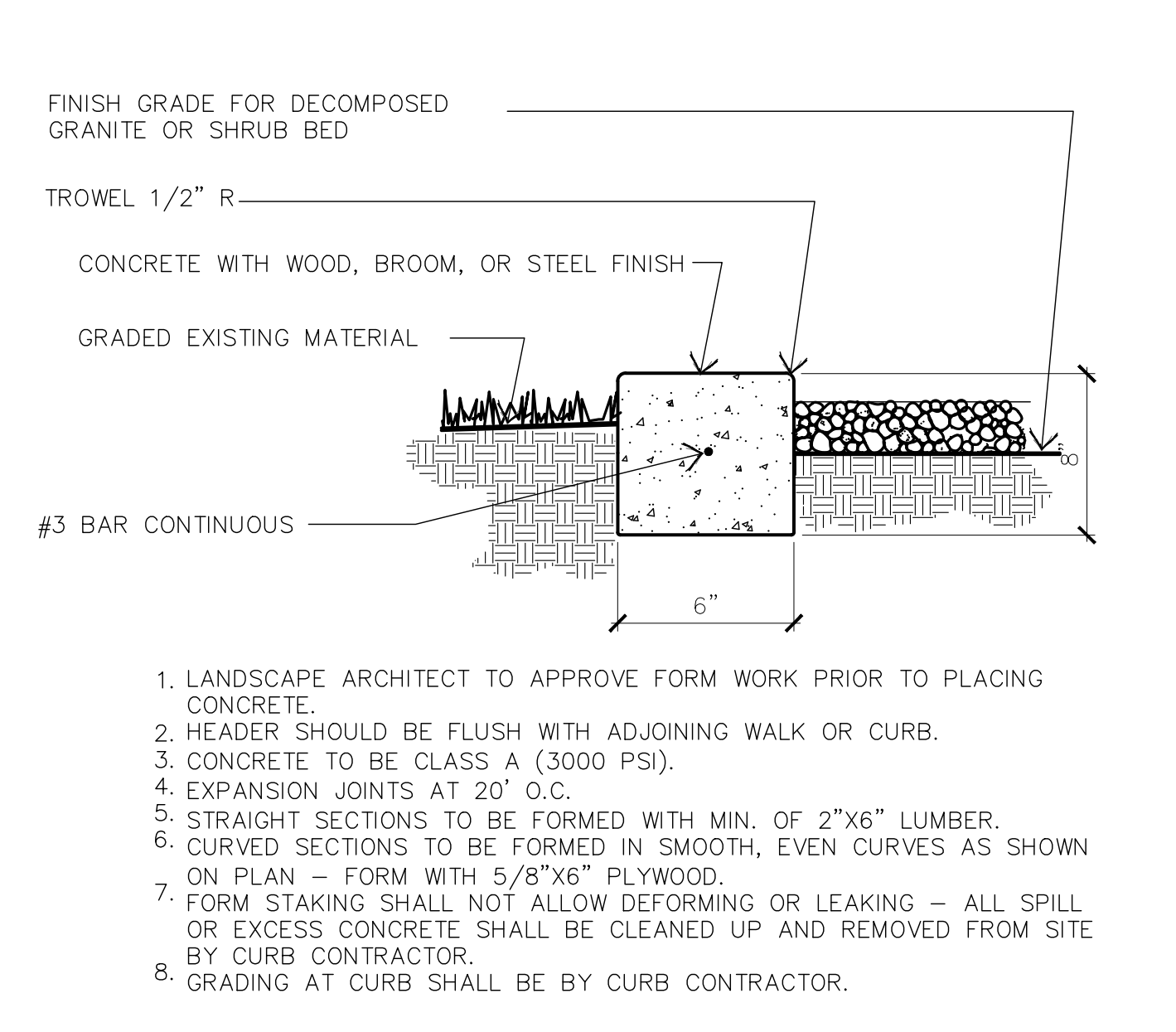

10 CONCRETE HEADER
SCALE: N.T.S. LD-2

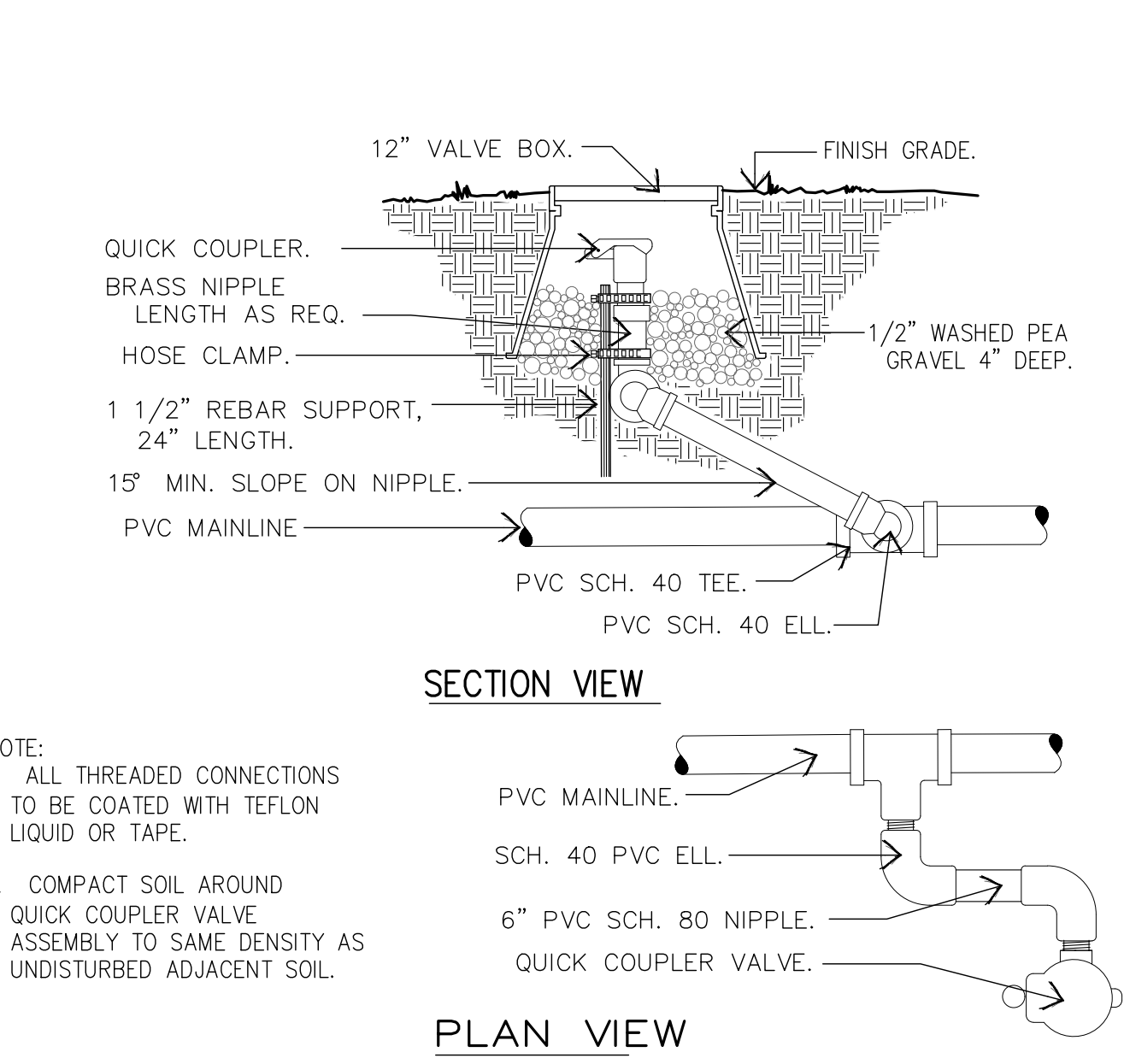

11 QUICK COUPLER DETAIL
SCALE: N.T.S. ID-1

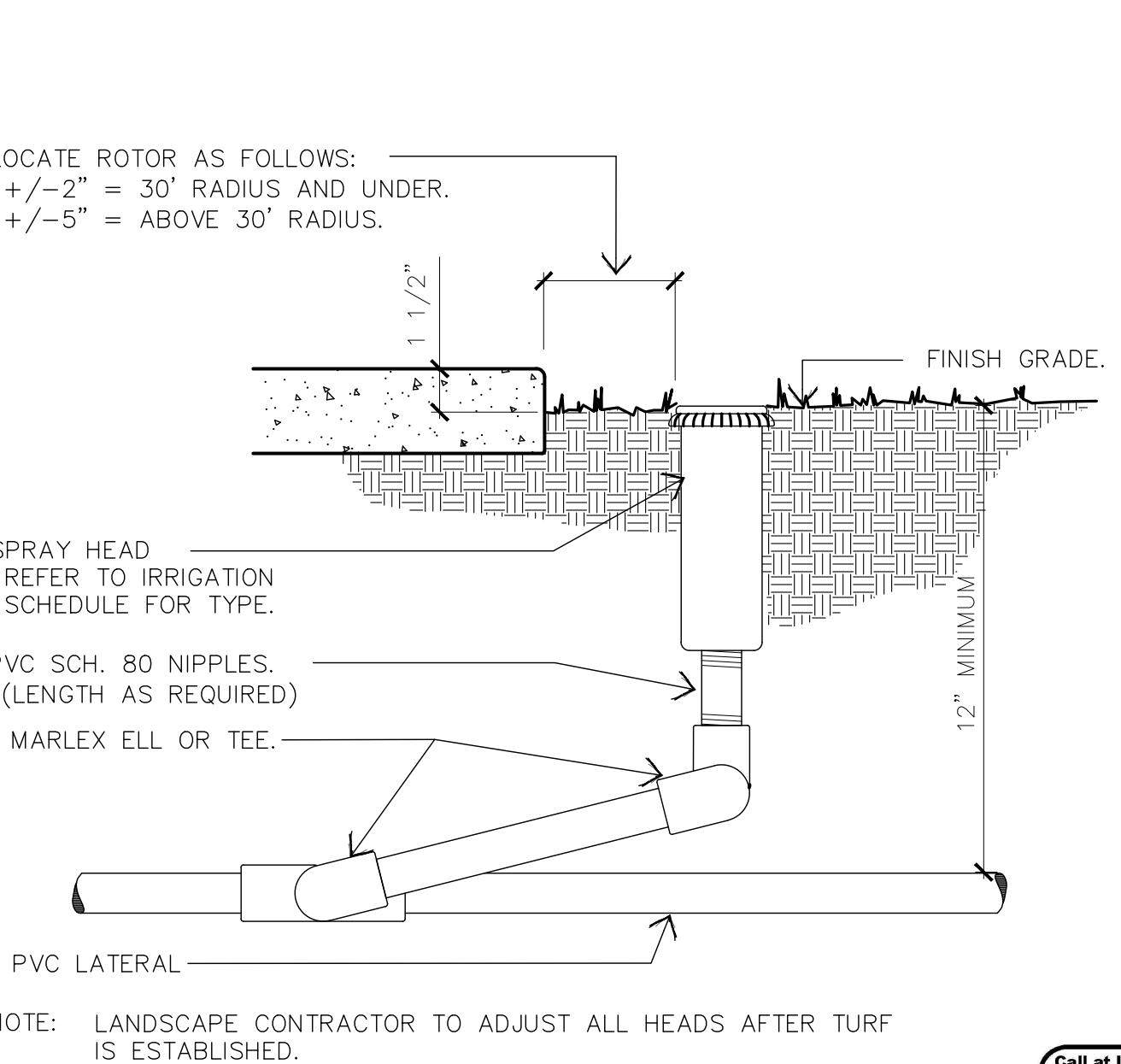

12 ROTOR POP-UP
SCALE: N.T.S.



Landscape Architecture
Land Planning
Urban Design
phone 480.949.7127
fax 480.949.2655
neill@neillandyoung.com
3295 north drinkwater blvd
suite 112
scottsdale, arizona 85251

neill + young
a s s o c i a t e s , l l c



City of Sedona Posse Grounds Park
Pickleball Court Irrigation
102 Roadrunner Dr.
Sedona, AZ 86336

DATE: 04-08-24
JOB NO:
DRAWN BY: NYA
DESIGNED BY: NYA
SCALE:
REVISIONS: DATE:
SUBMITTED FOR: Not For Construction
SHEET NO. **L-2**
X OF

COPYRIGHT © 2015 BY NEILL AND YOUNG ASSOCIATES, L.L.C. ALL RIGHTS RESERVED. NO ALTERATIONS TO THESE PLANS ARE ALLOWED OTHER THAN AUTHORIZED NEILL AND YOUNG EMPLOYEES. THIS DOCUMENT IS THE SOLE PROPERTY OF NEILL AND YOUNG ASSOCIATES, L.L.C.

COPYRIGHT © 2024 BY NEILL+YOUNG ASSOCIATES. NO ALTERATIONS TO THESE PLANS ARE ALLOWED OTHER THAN AUTHORIZED NEILL+YOUNG EMPLOYEES. THIS DOCUMENT IS THE SOLE PROPERTY OF NEILL+YOUNG ASSOCIATES.

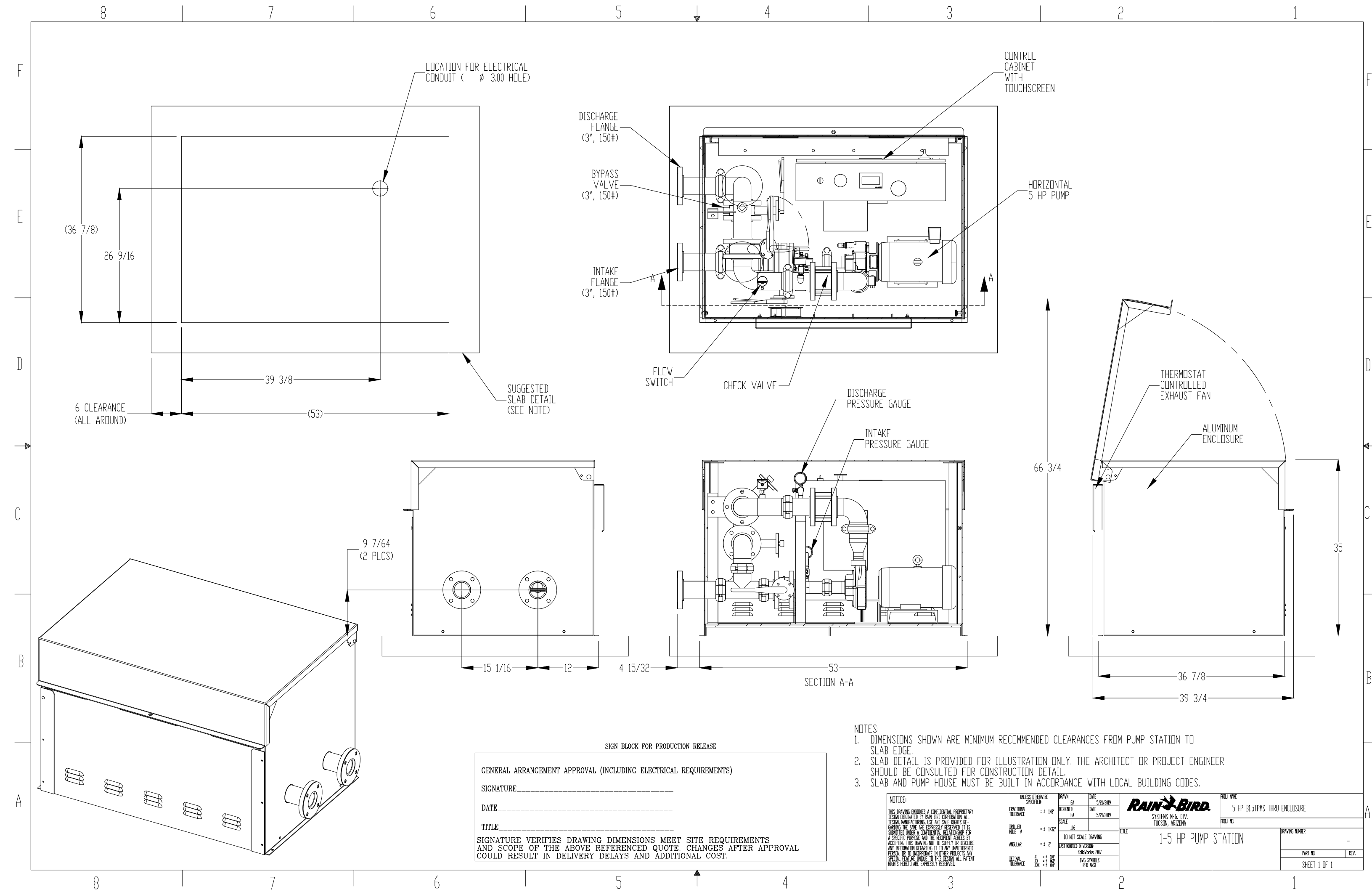

THE CONTRACTOR SHALL BE RESPONSIBLE FOR SCHEDULING AN ONSITE VISIT WITH A REPRESENTATIVE FROM THE MANUFACTURER OF THE IRRIGATION BOOSTER PUMP TO REVIEW, INSPECT, AND CERTIFY THE PUMPS 100% COMPLETE OPERATION. NO SUBSTANTIAL COMPLETION WILL BE GRANTED BY THE PROJECT LANDSCAPE ARCHITECT UNTIL THIS SCOPE ITEM HAS BEEN SUCCESSFULLY ACHIEVED AND WRITTEN DOCUMENTATION HAS BEEN PROVIDED BY MANUFACTURER REPRESENTATIVE.

CONTACT FOR RAIN BIRD
 NAME: MATTHEW HAITH
 PHONE: 1 (914) 573-2552
 EMAIL: mhaith@rainbird.com

1 RAIN BIRD IRRIGATION BOOSTER PUMP
 SCALE: N.T.S.

Landscape Architecture
 Land Planning
 Urban Design
 phone 480.949.7127
 fax 480.949.2655
 neill@neillyoung.com
 3295 north drinkwater blvd
 suite 12
 scottsdale, arizona 85251
neill + young
 associates, llc

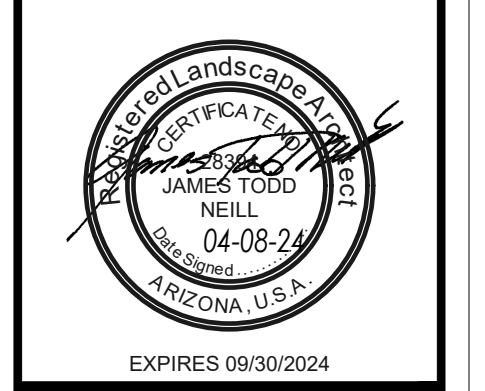

City of Sedona Posse Grounds Park
Pickleball Court Irrigation
 102 Roadrunner Dr.
 Sedona, AZ 86336

DATE:	04-08-24
JOB NO:	
DRAWN BY:	NYA
DESIGNED BY:	NYA
SCALE:	
REVISIONS:	DATE:
△	
△	
△	
△	
SUBMITTED FOR:	Not For Construction

SHEET NO.
L-3
 X OF



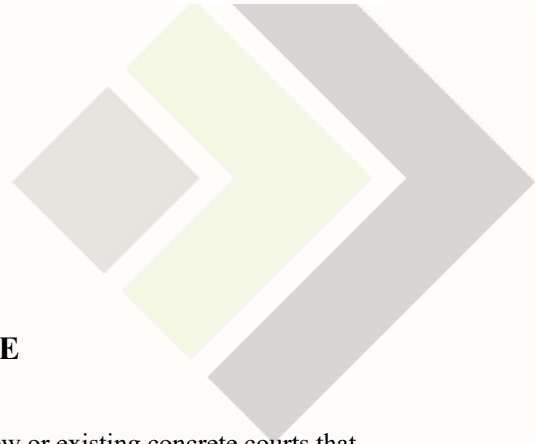

PLEXIPAVE INSTALLATION GUIDE

DESCRIPTION

This specification covers the application of a new Plexipave athletic surface on new or existing concrete courts that have a sound, well-drained base of adequate thickness and stability.

ACCEPTABLE BASE SPECIFICATION

The success of the all-weather characteristics of resurfacing is dependent on a sound base (with good drainage) and asphalt or concrete meeting the requirements of American Sports Builders Association. Surface variation should not exceed 1/8 inch in ten feet when measured in any direction with a straightedge and a slope of 1 inch in 10 feet, all in one plane. Surfaces should be properly sloped for good drainage, and free from cracks.

New Concrete- CSS requires a minimum cure time of 28 days on new concrete. Concrete must have vapor barrier installed below the slab to prevent moisture transmission. Concrete should have a medium-broom finish to allow for proper adhesion. Absolutely no concrete curing compounds may be used. Lightweight concrete is not an acceptable substrate. If water-proofing products are installed on the concrete, the supplier needs to guarantee that their system is compatible with acrylic coatings.

CONCRETE PREPARATION

New concrete must be acid-etched with either phosphoric, muriatic acid and must be thoroughly rinsed to remove laitance and salt and to reduce alkalinity. California Concrete Preparer is a self-neutralizing alternative.

California Ti-Coat Epoxy should be installed as an adhesion promoter prior to the Acrylic Resurfacer.

Ti-Coat Part 'A'	Ti-Coat Part 'B'
Equal parts	Equal parts
Let mix stand for 20 minutes prior to application.	
Coverage rate is approximately 300-400 square feet per gallon (28-37 m ² /gal)per coat, depending on the porosity of the surface.	

Use a short nap phenolic core roller. Apply a thin, wet coat. Be careful to remove any fat spots. Use all mixed material within 4 hours.

Ti-Coat will dry within three hours of the application. Acrylic Resurfacer applied within one to three hours of the application of Ti-Coat, while still tacky to the fingertip touch will provide maximum adhesion. Ti-Coat will dry faster on a hot day and slower on a cool day, but **in all cases Acrylic Resurfacer must be applied the same day.**

Existing Courts- Should be free of dirt, debris and any blistering or delamination of the existing coatings. Surface should be cleaned and pressure-washed to remove any loose coatings or contaminants. Any depressions or low spots should be repaired to bring the court to proper uniformity.

WEATHER LIMITATIONS

No part of the installation shall be conducted during rainfall, or when rainfall is imminent. The air and surface temperature must be a minimum of 50°F (10°C) and rising. Do not apply when surface temperature is above 140°F (60°C).

COURT PATCHING - The surface to be coated must be sound, smooth, and free from dust, dirt or oily materials. Prior to the application of surfacing materials, the entire surface should be flooded and left in direct sunlight for one hour under ideal conditions and checked for minor depressions or irregularities. Any puddled area that exceeds 1/8 inch in depth shall be marked and repaired with Court Patch Binder using the following mix:

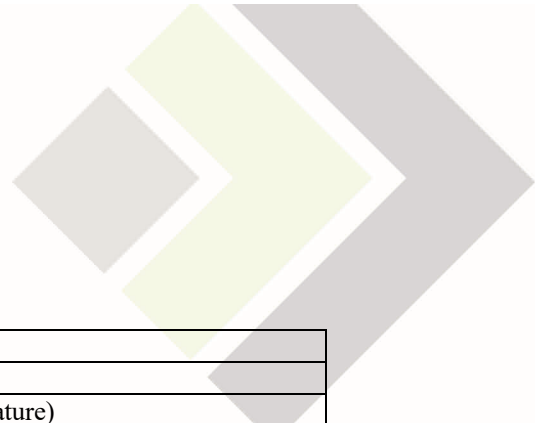

100 lbs. (45kg) of 60-80 mesh silica sand (dry)
3 gallons (10L) Court Patch Binder
12-24 lbs. (5.5-11 kg) dry Portland Cement (depending on humidity and temperature)
Tack coat consisting of 1-part Court Patch Binder and 2 parts water shall be applied to the patch areas and allowed to dry thoroughly prior to patching. After patching, the surface shall not vary more than 1/8 inch in ten feet measured in any direction. Edges of the patch should be sanded down, as necessary, to avoid ridges.

CRACK FILLING

California Crack Filler may be applied by hand trowel or small broad knife to force crack filler into cracks. Do not dilute. Cracks need to be cleaned and free of moisture. Will not prevent the reappearance of cracks in the substrate.

ACRYLIC RESURFACER

In order to provide a uniform, textured surface for the Plexipave system, Acrylic Resurfacer shall be applied to obtain a coverage rate of .05-.07 gallons per square yard (.16-.22 liters per square meter) per coat, prior to any dilution. On new or rough asphalt, a second coat may be necessary. No application shall be covered by a succeeding application until thoroughly cured. Dilution with water and sand is required utilizing the following mix ratio:

Acrylic Resurfacer	Sand 40-60 mesh	Mix	Clean, potable Water	Mix
18 gallons	225-250	5 minutes or until uniform	8-12 gals	5 mins or until uniform
Mix should not sit more than 20 minutes prior to application.				
Cure time is approximately 2-4 hours under ideal conditions.				
Liquid Yield 37-46 gallons (141-177L)				

Application methods:

- Use a 50-70 durometer rubber squeegee to level material across the court.
- After initial pour, acrylics should not be poured onto dry surface. Pour additional materials into existing wet windrow.
- Care should be taken not to leave ridges where adjoining applications overlap.
- Under hot conditions, application is improved by keeping surface damp with a fine mist water spray. Do not allow water to puddle.

FORTIFIED PLEXIPAVE (FIELD-MIXED)

Fortified Plexipave shall be applied to a clean, dry surface in a minimum of 2 applications to obtain a total quantity of not less than .10 gallons per square yard (.32 liters per square meter), prior to any dilution. No application shall be covered by a succeeding application until thoroughly cured.

Plexichrome Ultra Performance	Color Base	Mix	Clean, potable Water	Mix
10 gallons	15 gallons	5 minutes or until uniform	10 gallons	5 mins or until uniform
Mix should not sit more than 20 minutes prior to application.				
Cure time is roughly 4 hours under ideal conditions.				
Liquid Yield 35 gallons (133L)				

The diluted material shall be homogenous. The finished surface shall have a uniform appearance.



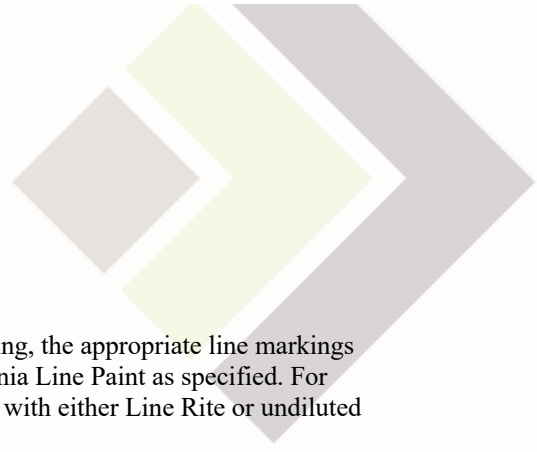

PLAYING LINES – Four hours minimum after completion of the color resurfacing, the appropriate line markings for the desired sport shall be accurately located, marked, and painted with California Line Paint as specified. For cleaner, sharper line markings, it is recommended that the masking tape be sealed with either Line Rite or undiluted Plexichrome Ultra Performance, prior to the application of the Line Paint.

Allow finished surface to cure a minimum of 24 hours before opening surface to use.

LIMITATIONS

Will not prevent surface or structural cracks from occurring or reoccurring

Will not prevent metal or organic staining if there are contaminants in the subsurface.

Do not allow product to freeze.

Do not store in direct sunlight.

Indoor applications will require a minimum constant temperature of 70°F (21°C) and proper air ventilation.



PLEXIPAVE HARDCOURT SURFACE SYSTEM

Tennis players everywhere attest to the superior playability of the Plexipave System. Plexipave's speed of play makes it possible for all types of players to excel, and its distinctive qualities of consistently true bounce and sure footing enhance coaching, training and competition.

Available Versions: Plexi Standard • Plexi H.U. (slower, more textured version) • Plexi I.W. (the slowest of all versions)

1. Concrete or Asphalt

2. Acrylic Resurfacer

Acrylic Resurfacer blended with approved silica sand

3. Plexipave

Sand-fortified Plexipave color provides a uniform surface texture and determines the speed of play and traction of the court

4. Line Paint

A heavy bodied acrylic latex

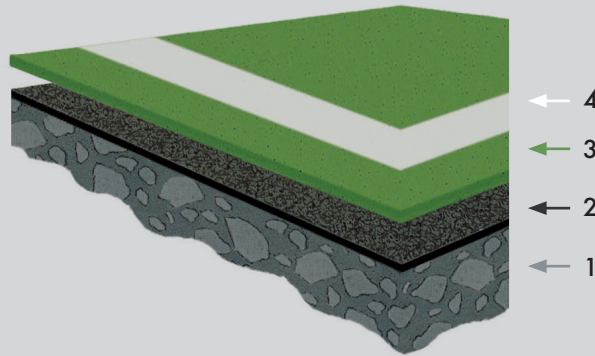

Diagram not to scale

- The #1 selling acrylic sports surface in the world
- Easy to clean and maintain
- Chosen for use on athletic courts in public parks, schools, clubs, colleges and private residential courts
- Can be customized to meet preferred court pace rating
- Chosen by the BNP Paribas Open (Indian Wells, CA) for nearly 20 years
- Can be used for tennis, basketball, volleyball, pickleball, netball and whole variety of athletic uses
- 14 standard colors that are durable, vibrant and long-lasting colors. Custom colors available upon request
- Provides uniform bounce, long lasting color and sure footing



MULTI-SPORT SURFACE SOLUTIONS FOR:



BASKETBALL



PICKLEBALL



ROLLER SPORTS



TENNIS



NETBALL



MULTI-PURPOSE

Plexipave[®]

Plexipave®

Meet the champion of tennis surfacing systems

we take great pride in creating surfaces ideal for professional sports and recreation use. From athletic tracks to netball courts to multi-purpose sports, we offer a wide range of unique, decorative solutions that will enhance the quality of your project in every way.

PLEXIPAVE TENNIS SURFACES ARE AVAILABLE IN THIS ITF COURT PACE RATING CATEGORY

They can also be customized based on your personal preferences.



Top image:
BN Paribas Open
Indian Well Tennis Garden

Bottom image:
2018 Australian Open
Melbourne, Australia



OUR COMMITMENT TO QUALITY

Since 1953, California Sports Surfaces has provided customers with a premier offering of acrylic surface systems. Our products include DecoTurf, Plexipave, Rebound Ace, Premier Sports Coatings, Plexitrac, SignaSports, Sport Tough and StreetScape. We provide the world with comfortable, high-performance cushioned surfaces for a variety of professional, collegiate and recreational sports as well as decorative projects, bike lanes, parking lots and more.

United States: 150 Dascomb Rd., Andover, MA 01810 • Phone 978.623.9980
Australia: 30 – 32 Assembly Drive, Tullamarine, Victoria, 3043 • Phone (Toll Free) 1800 786 617 • In Australia: +61 3 9338 9851

www.icpgroup.com
©2023 ICP Group



Plexipave[®]

MORE COLORS, MORE POSSIBILITIES



CALIFORNIA[®]
SPORTS SURFACES

Plexipave®

NEW COLORS. NEW POSSIBILITIES.

Our surfaces are superior in every way — even when it comes to style. Our team actively collaborates with owners, governing bodies and event organizers in selecting colors that help balance visibility, aesthetics and surface temperature.

Plexipave Ultra Performance formulation provides an all-weather, durable, quick-drying color surface engineered to resist deterioration from UV rays. Even if you're applying to asphalt or concrete, we'll make your project a hit.

PLEXIPAVE® TENNIS SURFACES ARE AVAILABLE IN THESE ITF COURT PACE RATING CATEGORIES

They can also be customized based on your personal preferences.

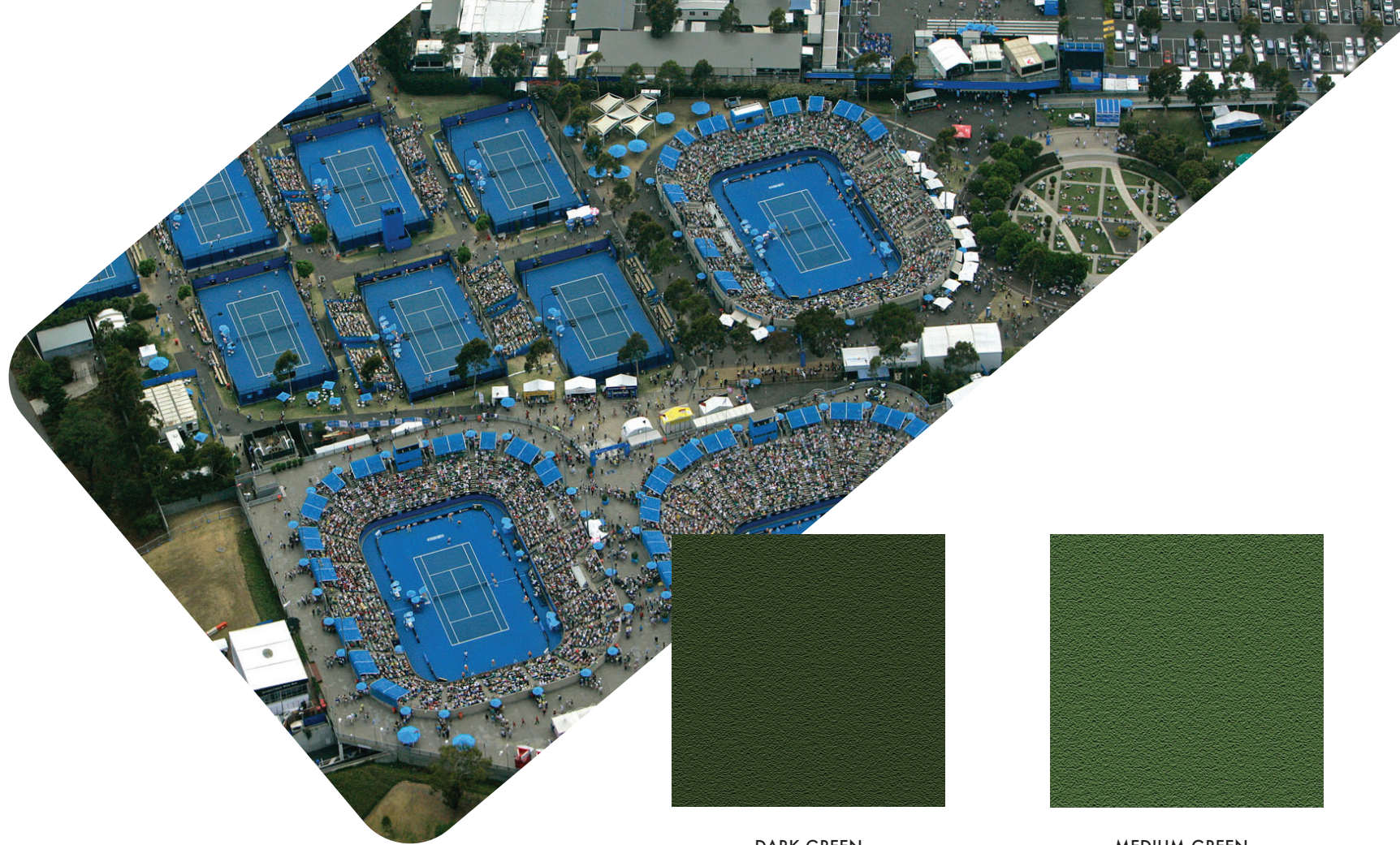

LINE PAINT

Also available in White and Textured White.

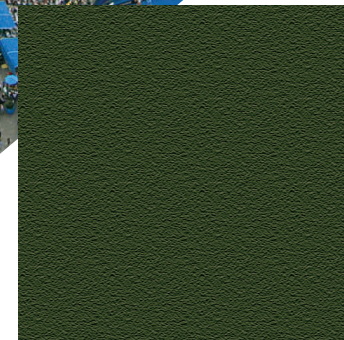
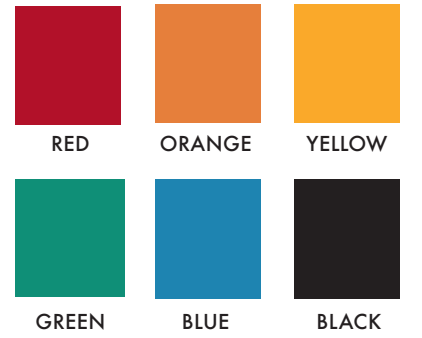

DARK GREEN

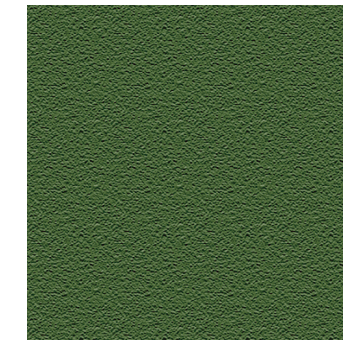

MEDIUM GREEN

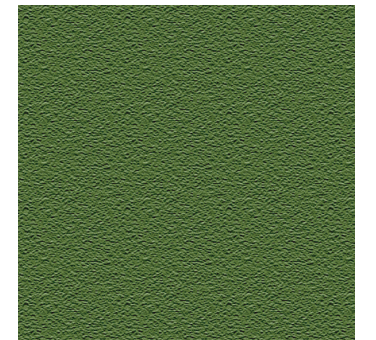

LIGHT GREEN

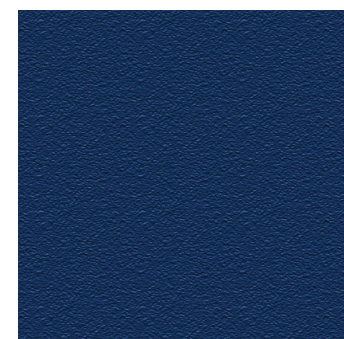

DARK BLUE

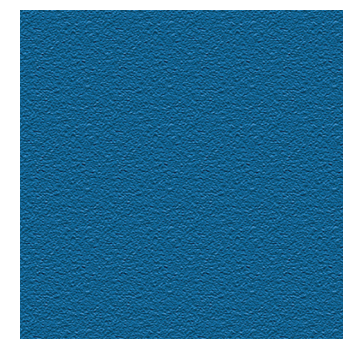

LIGHT BLUE



PURPLE

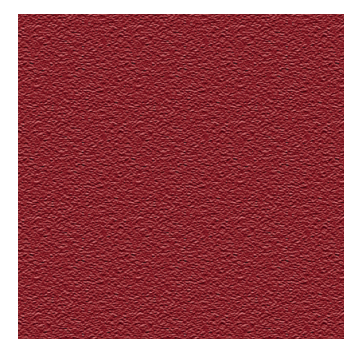

RED



GRAY

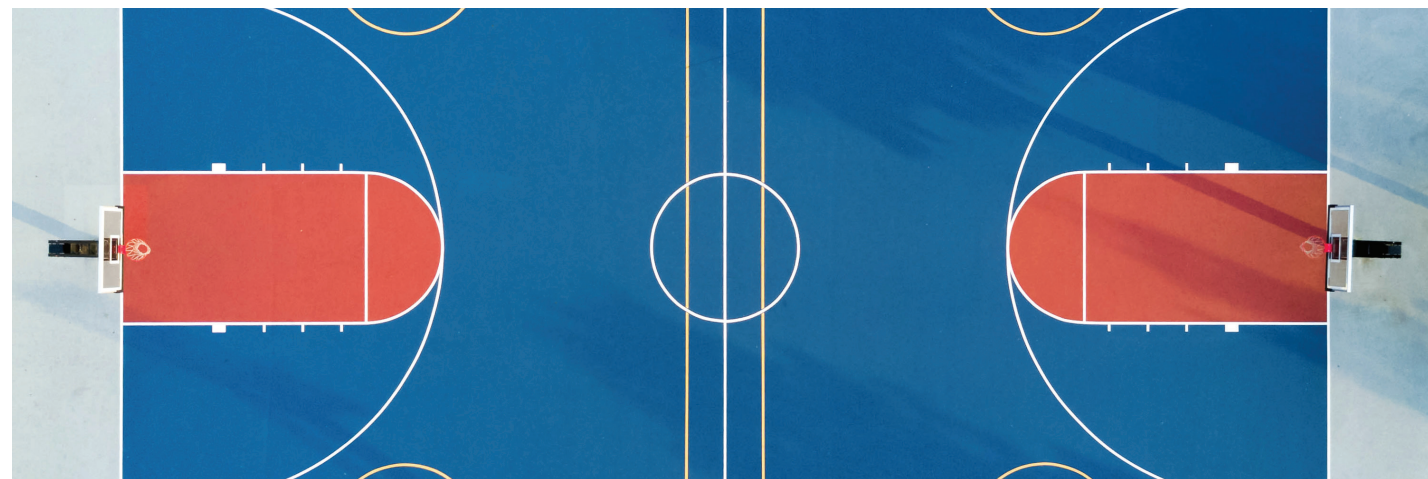

MULTI-SPORT SURFACE SOLUTIONS FOR:



BASKETBALL



PICKLEBALL



ROLLER SPORTS



TENNIS



NETBALL



MULTI-PURPOSE

AFFILIATIONS



International Tennis Federation



Chips on this card may vary in color and texture from the actual product. Special colors are available at a higher price based on pigments needed and production quantities.

**INDUSTRY
LEADER OF
ATHLETIC
SURFACING
SYSTEMS**

PRO PERFORMANCE, EVERYDAY PLAY

Meet the industry leader of athletic surfacing systems. Since 1953, Plexipave has been the original sports surface brand of choice for many high profile events, including the Australian Open from 2008 to 2018. We take great pride in creating surfaces that are ideal for professional sports and recreational use. From tennis and netball courts to multi-purpose sports, we offer a wide range of unique, decorative solutions that will enhance the quality of your project in every way.



CALIFORNIA[®]
SPORTS SURFACES

OUR COMMITMENT TO QUALITY

Since 1953, California Sports Surfaces has provided customers with a premier offering of acrylic surface systems. Our products include DecoTurf, Plexipave, Rebound Ace, Premier Sports Coatings, Plexitrac, SignaSports, Sport Tough and StreetScape. We provide the world with comfortable, high-performance cushioned surfaces for a variety of professional, collegiate and recreational sports as well as decorative projects, bike lanes, parking lots and more.

